



Chapter 13: Ground-fault testing

Introduction

A ground fault in a photovoltaic (PV) array is an accidental electrical short circuit between ground and one or more conductors that normally carry current. PV ground faults have many potential causes, but most result from improper installation or damaged components.

For example, a frayed wire brushing against a conductive metallic enclosure induces a current in the enclosure, and that electrical current looks for a low-resistance path to ground. If a technician's bare hand touches the enclosure, the technician's body can become one potential path to ground. In code-compliant PV installations, all non-current-carrying metallic equipment is bonded with low-resistance conductors to provide an alternative path to ground.

Ground-fault detection is typically automated by devices within the PV inverter, alerting the technician to the fault's presence. Locating the fault, however, is often challenging. This chapter explains a PV ground fault, relevant ground-fault electrical and safety considerations, and best practices for technicians to locate a ground fault in the field.

Ground-fault concepts explained

To understand PV ground faults, a technician must first understand the core electrical concepts of voltage, current, and resistance. The **Voltage and Polarity chapter** and the **Current chapter** detail these concepts, and Ohm's Law helps to visualize the relationships.

Under normal operating conditions, the direct current (DC) produced by the PV modules flows to a string combiner box and into an inverter. Current-carrying conductors act as electron highways and form circular loops back to the source—the PV module. Damage to the current-carrying conductors can allow current to flow outside the intended path, creating shock and fire hazards.

Figure 13-1: PV modules are the start and end of every DC circuit in the system. Ground faults can happen anywhere along the current path.



Ohm's Law and Power Law

$$E = I \times R$$

E = Voltage in Volts

I = Current in Amperes

R = Resistance in Ohms

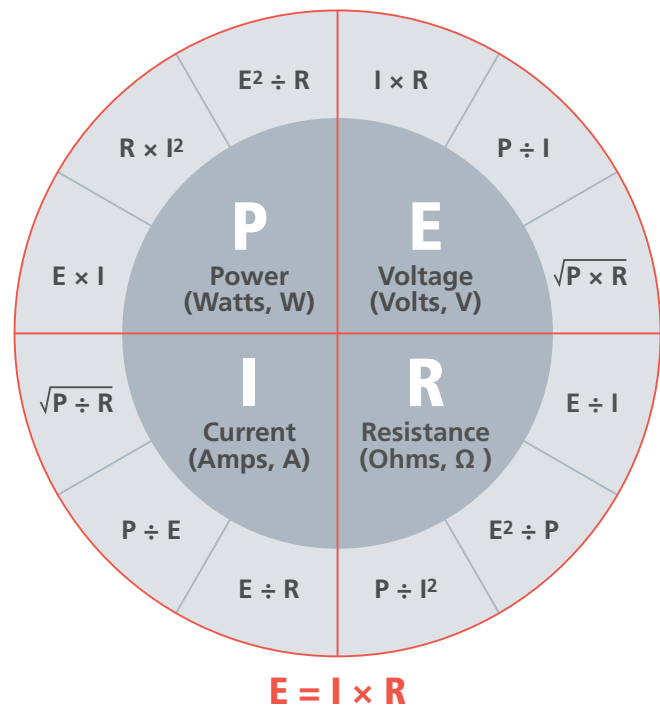

Figure 13-2: Ohm's Law describes the relationship between power and voltage, current, and resistance.

PV inverters have integrated ground-fault detector interrupters (GFDIs) to isolate affected circuits and to alert technicians when a fault current occurs. The GFDI is a crucial safety feature in PV systems that helps protect against electrical hazards. If a ground fault occurs, such as insulation failure or a leakage current path to the ground, the ground-fault device detects, interrupts, and alerts about this condition.

The ground-fault detector can take various actions depending on its design and the specific system setup. Common actions include:

- **Detection:** The ground-fault device detects a ground fault from the PV system.
- **Interruption:** When a ground fault is detected, some ground-fault devices automatically shut down the inverter or disconnect the PV system from the grid. This action helps prevent potential hazards and protects the system from further damage.
- **Alarming:** The ground-fault detector may trigger an audible or visual alarm to alert maintenance personnel or system operators about the ground-fault occurrence.
- **Remote communication:** In some cases, the ground-fault detector may communicate with a monitoring system to indicate the presence and location of the ground fault. This information can be helpful for maintenance personnel during troubleshooting and repair.

Following the manufacturer's guidelines and local electrical codes is essential when installing and configuring ground-fault detectors for nonisolated PV systems. Proper grounding, bonding, and fault detection are crucial for safe and reliable operation of the PV system.

Grounding systems and terminology

In electrical systems, grounding establishes a stable electrical reference point, often called the ground potential. In electrical terminology, ground and earth are interchangeable and denote a universal reference for the circuit. This reference point enables consistent measurement of voltage levels in the system. It facilitates the proper functioning of electronic devices and protects against high-surge events from lightning and utilities.

Two primary types of grounding exist in PV arrays: system grounding (earthing) and equipment grounding (bonding). For additional protection, all PV systems should be equipment-grounded and interconnected to grounded electrical systems.

Grounding / earthing system components and terminology

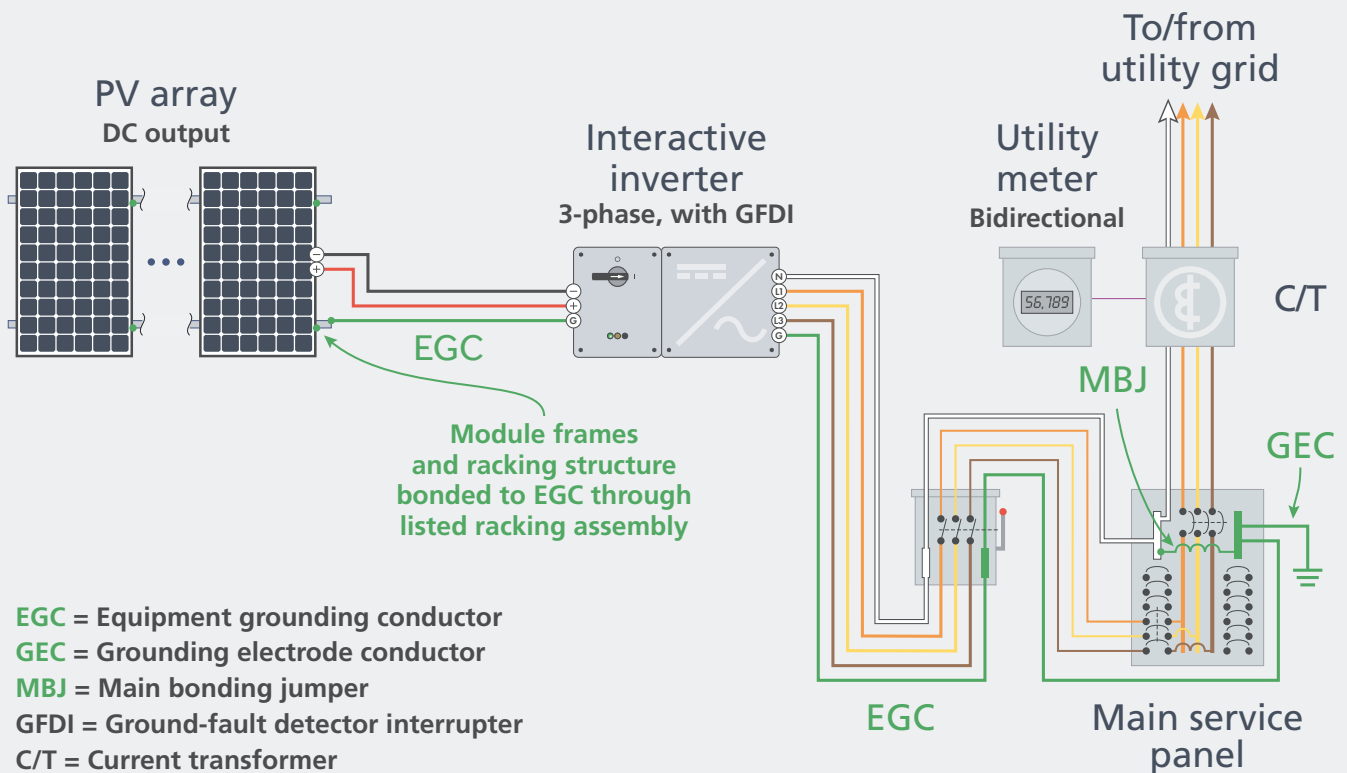

Figure 13-3: PV systems use equipment grounding (bonding) to keep all metallic components at the same potential and to facilitate ground-fault protection. In addition, they use grounding systems on the utility side per local codes and regulations. Note that the EGC connects all metallic components to the GEC, which is bonded to the grounding electrode.

The exact system grounding (earthing) methodology is a function of the type of inverter that is installed (discussed in the **Inverter topologies and ground-fault detection** section below) and the alternating current (AC) electrical system with which the PV system interconnects. PV systems that are connected to dedicated services from the utility have the same type of grounding system installed as for any conventional electrical service.

Ground fault state & GFDI operation

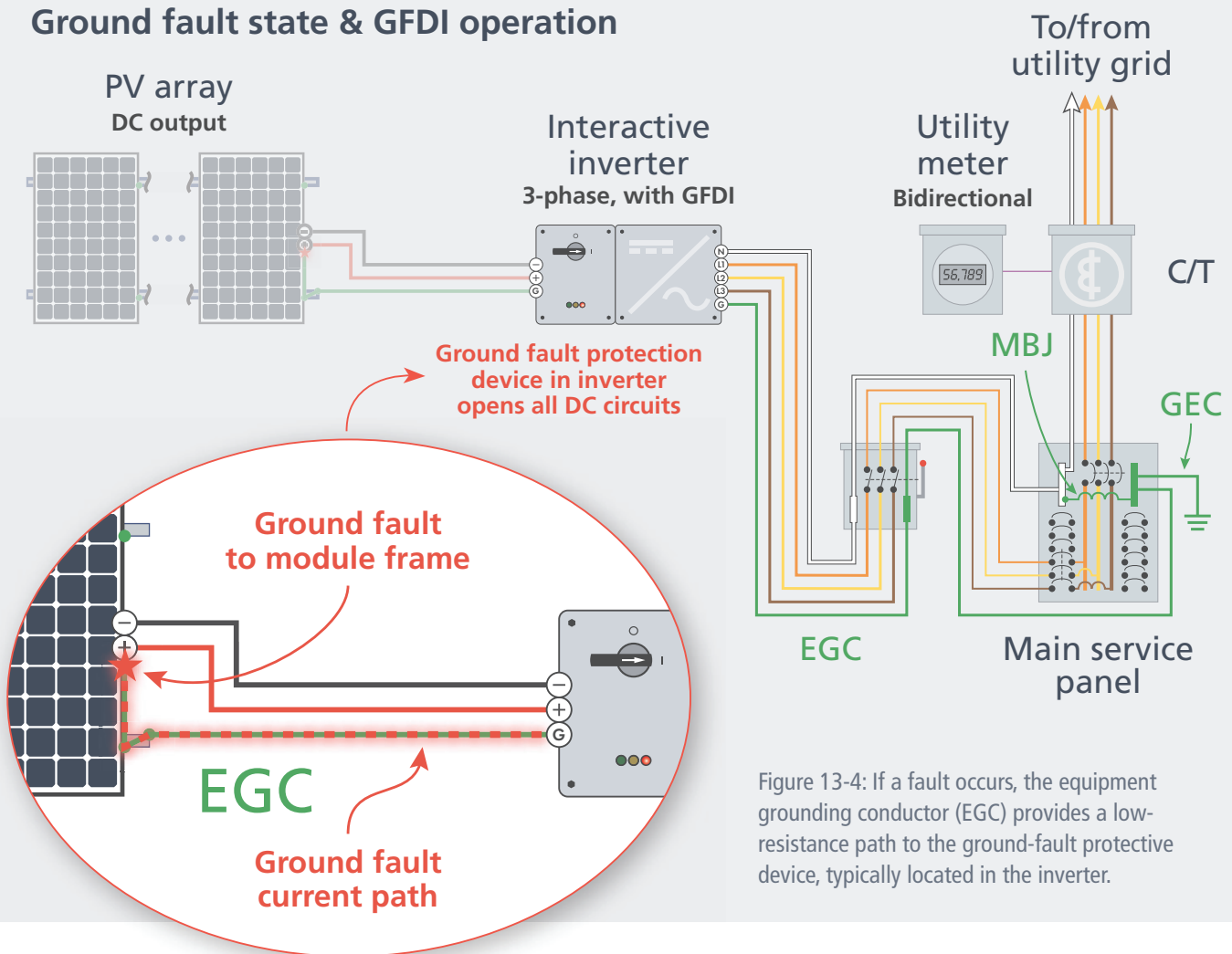
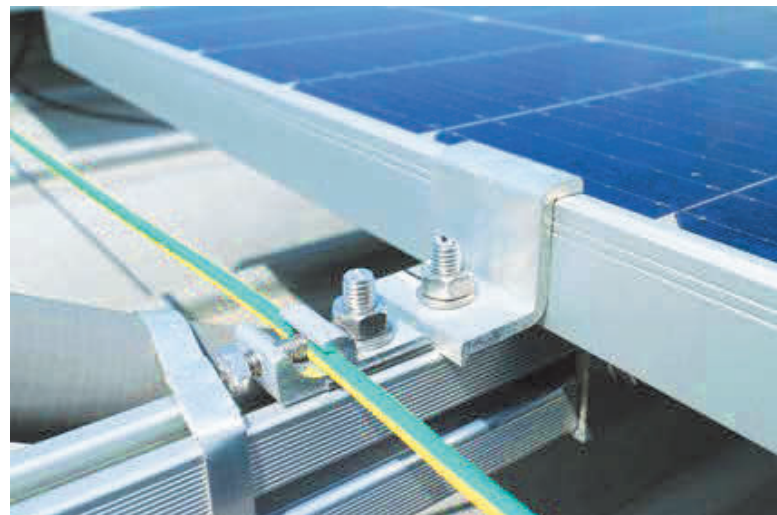

Figure 13-4: If a fault occurs, the equipment grounding conductor (EGC) provides a low-resistance path to the ground-fault protective device, typically located in the inverter.

To facilitate a low-resistance connection between all the materials, all PV systems should include an equipment grounding (bonding) system that bonds all the metallic frames and components. If a ground fault occurs, the current from that fault therefore has a direct path to the PV inverter and to the ground-fault detector. Equipment bonding is a critical component of all PV installations. Verification of proper connections is discussed in detail in this guide's **Electrical Continuity** chapter.

Figure 13-5: An equipment grounding conductor bonds adjacent metal components such as PV racking and provides a low resistance path for fault currents to the ground fault protective device.



Inverter topologies and ground-fault detection

Technicians typically encounter two types of inverters on PV sites: nonisolated (transformerless, and also previously referred to as ungrounded) inverters and isolated (transformer-based, and previously referred to as grounded) inverters. The critical distinction is the presence of an isolation transformer within the inverter that completely separates the DC side of the system from the AC side.

Modern PV installations rarely use isolated inverters, but they were commonplace in the past. Technicians are likely to encounter both types of inverters and should be aware of the differences, especially regarding ground-fault protection.

Figure 13-6: A nonisolated inverter gives a visible indication of a ground fault.

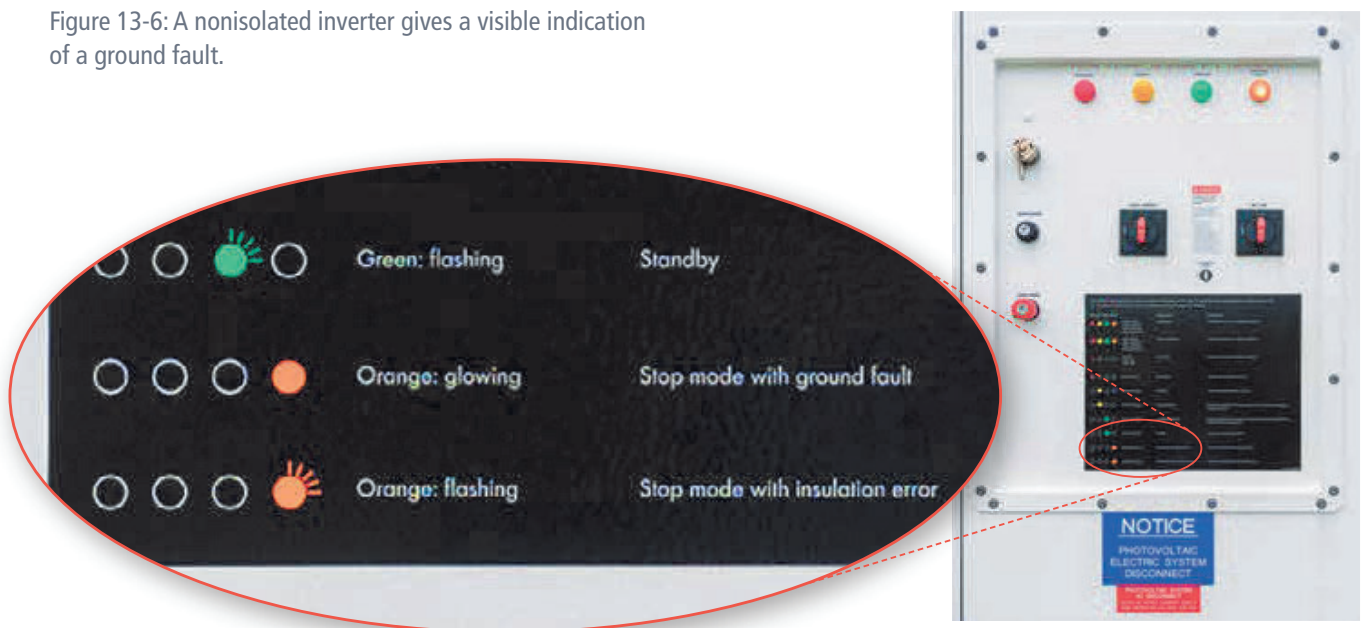

Nonisolated (transformerless) inverters

In a nonisolated PV inverter, the PV module's positive and negative DC conductors directly connect to the inverter's DC input terminals. These inverters use capacitive coupling to connect the DC conductors to the ground.

The inverter has capacitors between the positive and negative DC input terminals and ground. When the inverter operates, a small amount of current, known as leakage current, flows through the capacitors to the ground. This leakage current is typically minimal but is enough to connect to the ground without an isolation transformer.

Nonisolated inverters have ground-fault detection mechanisms. Suppose that any fault in the system causes a higher current flow to the ground than the normal leakage current. In that case, the inverter's ground-fault protection system detects the higher current flow and shuts down the inverter for safety. These ground-fault detection devices use a residual current detector that enables the inverter to detect faults with small current flows, as low as 300 mA. These inverters are considered safer than transformer-based inverters, partly due to this enhanced detection sensitivity.

Nonisolated inverter GFDI topology

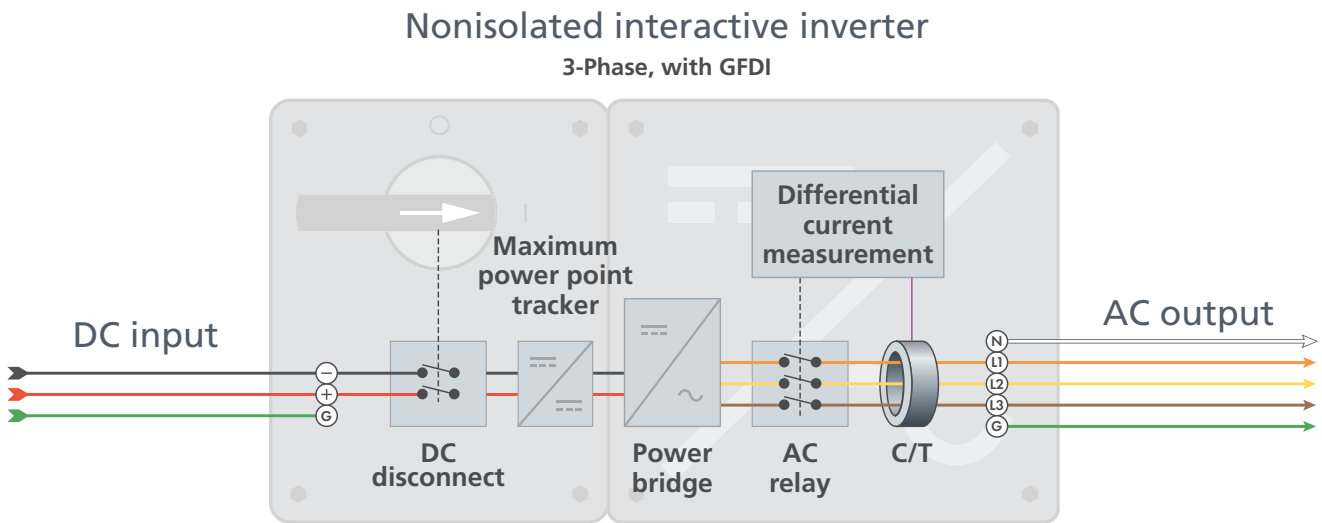

Figure 13-7: A nonisolated inverter uses a differential current measurement to monitor for ground faults. This device is more sensitive to ground faults than the fuse-based method that isolated inverters use.

Another feature of nonisolated inverters is that they perform an insulation resistance measurement each day before the inverter produces power. The test helps identify any damaged conductors. To avoid false positives, the passing threshold for this test is generally lower than as described in the [Insulation Resistance Testing](#) chapter.

The advantages of nonisolated PV inverters include higher efficiency due to eliminating losses associated with the isolation transformer, reduced size and weight, and overall cost savings. However, because grounding requirements and regulations vary by country and region, it is essential to comply with local codes and standards when installing nonisolated PV inverters.

Isolated (transformer-based) inverters

Isolated inverters use an internal transformer to isolate the DC that is produced by the PV modules from the AC that is connected to a utility. These systems are commonly called DC-grounded systems.

In these inverters, the ground-fault protection bonds a current-carrying conductor to the grounding conductor across a fuse. If a fault within the PV array occurs, the system is protected because the current flows on the equipment grounding conductor (EGC) and completes the path back to the PV modules across the fuse. When the fuse opens, the inverter displays a ground-fault message, and it ceases power production, stopping the current flow in the array.

The exact fuse size that is used in the ground-fault protection is a function of the inverter size. The ground fault must exceed a current value before the ground fault is detected and interrupted. For example, small residential inverters are typically protected with a 1 A fuse, and larger commercial inverters use up to a 5 A fuse. Technicians need to understand how any inverter that they are maintaining is protected. The fuses that are required for these ground-fault protective devices may be special-order items.

Isolated inverter GFDI topology

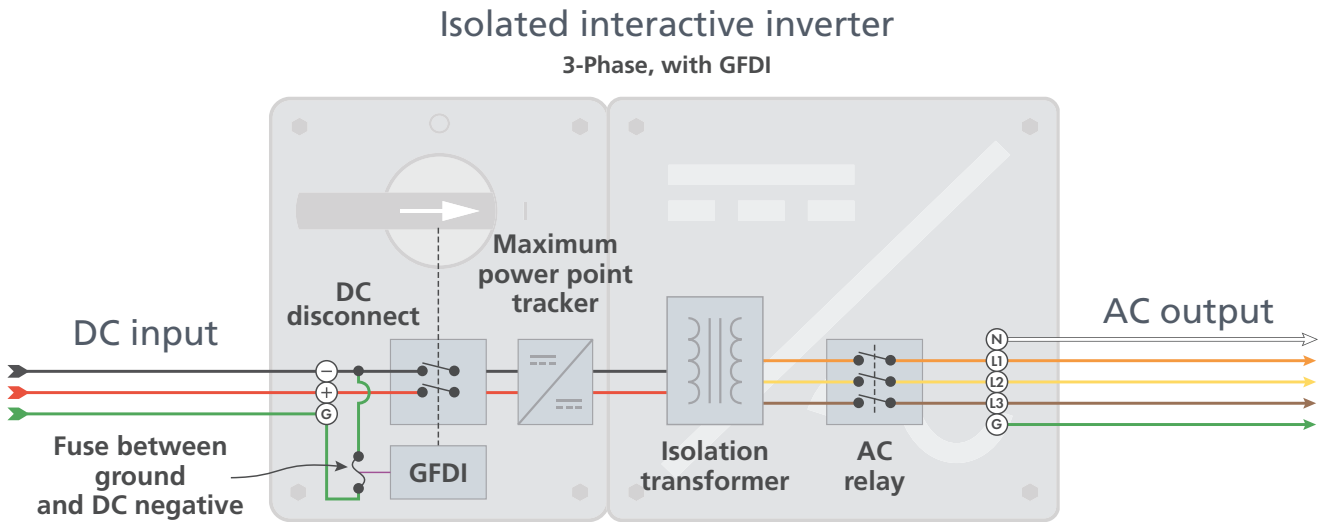

Figure 13-8: An isolated inverter uses a ground-fault protection system that integrates a fuse into the protective device. When a fault occurs, current flows on the bonded metallic components and through the fuse. When the fuse blows, the inverter shuts down, and an indication light alerts that a fault is present.

In the early 2010s, the Solar America Board for Codes and Standards (Solar ABCs) published “Analysis of Fuses for ‘Blind Spot’ Ground Fault Detection in Photovoltaic Power Systems” and “Inverter GroundFault Detection ” and “Blind Spot” and Mitigation Methods” detailing isolated inverters and their protective devices. These reports detail the potential problems of isolated inverters and their associated ground-fault protection. The results of the Solar ABCs reports helped to propel the transition away from isolated PV inverters and toward nonisolated PV inverters.

Figure 13-9: When a ground fault is known to be present, technicians should wear appropriate PPE and avoid direct contact with any exposed metal components.



GFDI versus GFCI

The two most common ground-fault detection devices in PV systems are ground-fault detector interrupters (GFDIs) and ground-fault circuit interrupters (GFCIs). PV inverters have integrated GFDIs. GFCI devices are commonly installed in building electrical systems to reduce shock hazards to humans.

GFDIs detect current flow between a PV system conductor and ground in the inverter. These devices use fuses that are rated for 1 A to 5 A, or they use residual current detectors that sense current imbalances as low as 300 mA. When the GFDI opens, the flow of ground-fault current stops, and the inverter turns off and alerts the system owner that a fault was detected.

GFCIs look for an imbalance between the inflow and outflow of current through a circuit, indicating that some current is flowing to ground. GFCIs are highly sensitive, detecting current imbalances as low as 4 mA or 5 mA. Areas with a high risk of electrical shock, such as bathrooms and kitchens, require GFCI installations.



Figure 13-10: GFCIs are common throughout North America as protection devices to reduce shock hazards.

Technicians must be aware of these inverter and GFDI methods when they are troubleshooting arrays. In either situation, shock and electrocution are risks when a ground fault is present. When technicians are working on a system where a ground fault has been detected, they should wear personal protective equipment (PPE), avoid direct contact with metal parts, and generally proceed with caution.

False detections of ground faults are rare but not unheard of, and far less common than genuine faults. Intermittent ground faults are the hardest to find, and testing may not clearly indicate their location. In that situation, field technicians may falsely assume that no fault exists and give the system a clean bill of health, only to have the fault resurface later.

Environmental impacts on ground faults

Previous chapters discussed the correlation between irradiance, temperature, and PV array output. Sunnier conditions, for example, result in higher PV module output current. In contrast, the relationship between ground faults and environmental conditions is much more open-ended. Although damage from acute weather events such as hailstorms and lightning strikes may directly cause ground faults, improper installation or long-term climatic effects are just as likely to be the root cause. This section overviews some critical factors that technicians should consider when they are working on PV systems.

Installation errors

Ground faults that appear during commissioning are almost always the result of an installation error. Conductors that are inadvertently crushed between the module frame and the racking system are an example of such an error. Another common error is a conductor being damaged as it is pulled through a conduit, resulting in a connection to a metallic component.

Acute weather events

PV arrays, composed mainly of conductive metal equipment that is installed in an open field, are susceptible to lightning strikes. Proper grounding and system protection minimize equipment damage from lightning strikes. Lightning arresters, surge protection devices, twisted-pair wiring, and properly installed grounding systems can all mitigate the safety risks from lightning.

Long-term environmental effects

PV systems that are installed outdoors inherently are exposed to cycles of hot and cold weather and dry and wet periods that slowly wear down their equipment. Repeated expansion and contraction can degrade conductors or create microcracks within the PV cells. Moisture ingress within modules or connectors is common in regions with high humidity or consistent rainfall.

Damage from local wildlife

Among the most notable environmental risks to a PV system is local wildlife. In particular, the warmth and shade that an array provides may entice rodents. Hungry rodents, squirrels, deer, and other animals can gnaw through the insulation on PV conductors, which can degrade system performance and lead to ground faults or arc-flash hazards. Technicians should be aware of any onsite animal populations that are living in or near the PV array.

Rain exposure

Ingress of rain, especially in quick connects, can cause ground faults. This occurs when the water completes a circuit while dry conditions maintain a separation between the conductors and the metallic system supporting equipment. Ground fault alerts generated on rainy days are generally intermittent, and may be difficult to locate when environmental conditions are not the same. These intermittent faults may require a “wet” insulation resistance test, as described in the step-by-step instructions described in this chapter.

Types of ground-fault tests

To find the source of a ground fault, technicians must be able to perform a wide range of tests. Generally, it is a best practice to start at the inverter level to cast as wide a net as possible, then narrow the tests to the combiner and eventually to the string level to isolate the fault. This section describes the most common tests that are used to locate ground faults. For detailed instructions, see the [How to perform ground-fault tests](#) section.

Voltage measurement

Technicians should begin by measuring and recording the voltage from positive to negative, positive to ground, and negative to ground for all string or combiner inputs. Under normal operating conditions, the voltages from positive to ground and negative to ground should be near zero, which indicates that there is not a fault to ground. When the positive-to-ground and negative-to-ground readings are nonzero and out of balance, technicians can use the voltage measurements to home in on the fault location. Voltage readings are expected to reduce over time, but not drop to zero. The [How to perform ground-fault tests](#) section further defines the voltage test sequence.



Figure 13-11: Technicians can estimate the point within a PV string where a ground fault has occurred by using the rated open-circuit voltage (V_{oc}) for the PV module and the voltage measured from positive to ground and negative to ground.

Visual inspection

Voltage readings help to home in on the ground-fault location. After the technician has narrowed the search to the string or combiner-box level, a visual inspection of the region may be sufficient to find the source of the ground fault. During the inspection, technicians should be on the lookout for visibly burned conductors or connections, signs of arcing on the racking system, and modules with visible burns or defects.

Insulation resistance testing

Often, voltage tests and visual inspection results are inconclusive. Suppose that a technician has narrowed the search to a string or combiner-box level, but the exact location of the ground fault still needs to be determined. In that case, insulation resistance tests can help verify that conductors are working properly. A damaged conductor—from a weather event, long-term environmental exposure, or a hungry rodent—is one of the most common causes of ground faults.



Figure 13-12: Once the fault location has been narrowed down to the string or combiner-box level, technicians should visually inspect the conductors in that region to look for signs of damage.

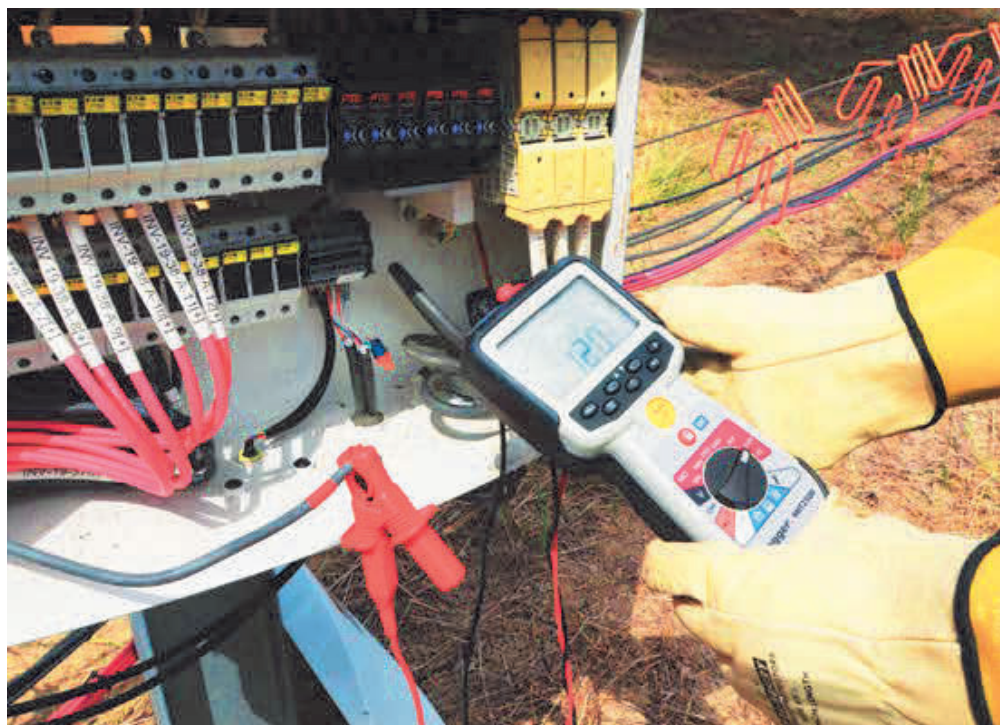

Figure 13-13: A high-range ohmmeter can be used to measure the insulation resistance of conductors in the affected region.

Technicians use an insulation resistance tester or a high-range ohmmeter to apply DC voltage across the conductor that is being tested and to inject a small current through it. The insulation resistance tester then uses Ohm's Law to calculate the insulation resistance from the known voltage and current. Insulation resistance values that are below a certain threshold—as described in the **Insulation Resistance Testing** chapter—indicate that the conductor under testing is damaged and may be the cause of the ground fault.

Where to perform ground-fault tests

PV ground faults are notoriously tricky to pinpoint. Technicians should start by casting as wide a net as possible and then narrow their search through additional testing. Typically, this approach means beginning at the inverter level and then methodically segmenting the array.

If multiple combiner boxes are in the system, it is useful to isolate individual combiners to eliminate array sections and to perform the tests within the combiner boxes. Many modern inverters are considered string inverters because the PV strings are connected directly to the inverter's input terminals. In these scenarios, segmenting the array is easier because individual strings can be isolated for testing.

For testing through DC-to-DC converters, technicians must first verify the approved methods with the manufacturer, especially if insulation resistance testing is required. If these systems are improperly tested, damage may occur, leaving the array in worse shape than when a ground fault was the only problem.

Segmenting a PV system to find a ground fault

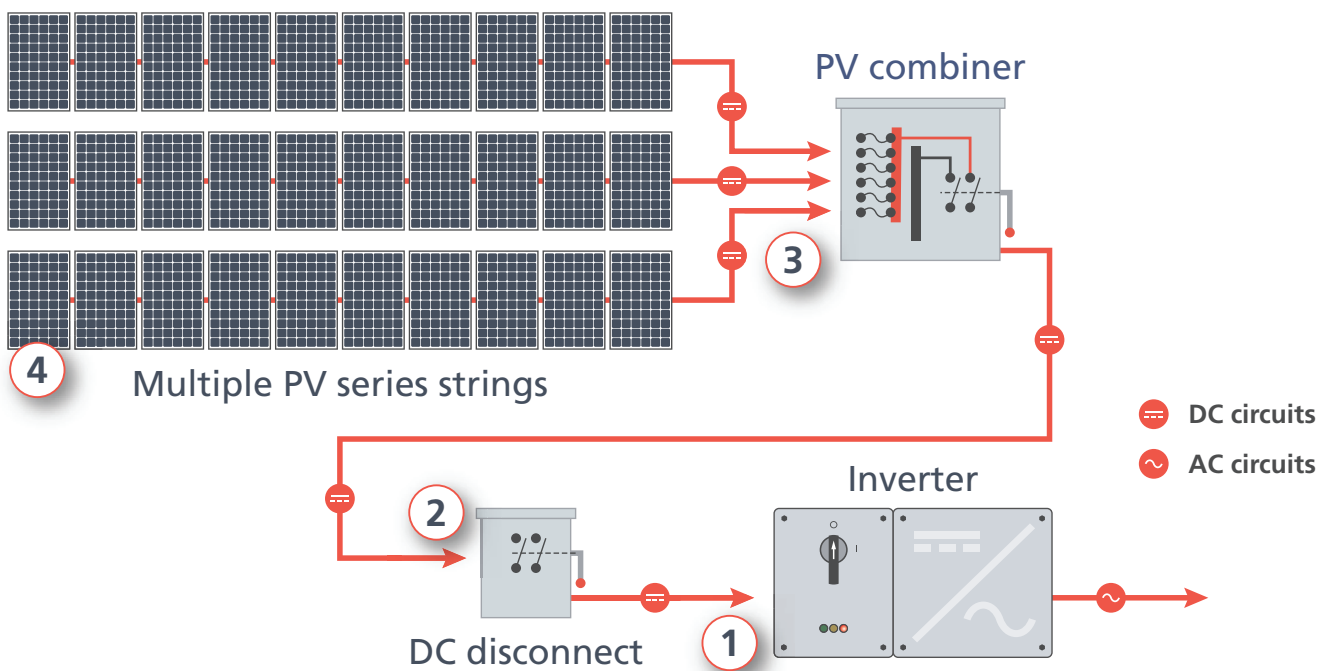

Figure 13-14: Fault path for a system-grounded PV array.

DC reading locations:

- 1 Inverter input circuit:** Isolate and test inverter inputs one-by-one. With circuit conductors isolated, insulation resistance measurements will identify faults in these conductors.
- 2 DC disconnect circuit:** Repeat the tests performed for inverter input circuits. Segmenting circuits helps troubleshooting and identifying faulted conductors.
- 3 Individual series strings:** Test each series string circuit to determine which string has the fault.
- 4 Individual PV module leads:** Test individual modules if all other tests do not indicate a ground fault in the circuit conductors.

Why measure ground faults?

Although many of the tests that are covered in other chapters in this guide, such as **Insulation Resistance Testing** and **Voltage and Polarity** verification, are required by code or commissioning standards, ground-fault tests fall into their own category.

Appropriate testing for PV systems

Properly installed PV systems should not have any ground faults, so ground-fault tests are generally a matter of reactive maintenance. In most cases, technicians perform ground-fault tests as troubleshooting in response to a dip in PV production or an alert from the inverter.

Codes and standards

Ground-fault detection is a critical safety feature in PV systems to protect individuals and the system from electrical hazards. PV inverters in Europe and North America, for example, must comply with their respective electrical safety standards.

In Europe, the common grid codes and standards for PV systems include the European standard EN 62109, which covers the safety of inverters for use with PV systems. This standard addresses various safety aspects, including ground-fault detection methods. The International Electrotechnical Commission standard IEC 62109-1 is also widely followed.

In North America, the primary standard for PV systems is the *National Electrical Code: (NEC)* Article 690, which outlines the requirements for PV systems. Specifically, NEC 690.5 addresses ground-fault protection. In addition, UL 1741 is the standard that is used for inverters, including provisions for ground-fault detection.

Relevant U.S. and EU ground-fault standards Figure 13-15

Europe	North America
EN 62109	NEC 690.5
IEC 62109-1	UL 1741

European and North American standards aim to ensure the safe operation of PV systems and to effectively detect ground faults. They may differ in specific requirements, but the overall objectives are similar—to safeguard individuals and the system from electrical hazards.

Operations and maintenance (O&M) plans

Many PV developers perform routine O&M in-house, or they outsource O&M to third-party service providers. Under such agreements, the O&M provider typically performs one or more site visits yearly to verify system performance and to troubleshoot any issues. Because ground faults are common in PV systems, all O&M technicians should be familiar with the tests to locate and to resolve ground faults in the field.

Ground-fault safety hazards

When a potential ground fault has been detected, unless extensive field testing shows that no fault exists, it is safe to assume that damage has occurred, repair is required, and there is an electrical hazard to the system. The system may continue operating, but technicians should proceed with utmost caution until they have resolved the ground fault.

While the ground fault is active, the bonded metallic components that make up the PV system may be energized. The risk of severe shock from direct contact with conductive components increases for high-voltage DC systems, such as utility-scale PV arrays, which operate at 1500 V DC.

The presence of a ground fault creates a safety hazard for technicians and for the equipment within the array. High-energy fault currents can spark fires and melt conductors, which can cascade throughout the rest of the system. Even small fault currents may be sufficient to damage equipment if the fault current exceeds what the equipment is rated to handle during normal operation.

Figure 13-16: Technicians should proceed cautiously if a ground fault is detected onsite. At higher system voltages, fault currents increase, also increasing the shock hazard.



How to perform ground-fault tests

To perform ground-fault tests safely and correctly, proper planning and understanding of the required methods are essential. Because ground faults can occur at any point in the PV system, there is no one-size-fits-all approach to testing. Instead, the following steps describe industry best practices that apply across various system sizes and types. Contact the inverter manufacturer for additional assistance if needed. A general approach is to start at the inverter level and to work down toward the PV array to troubleshoot and to isolate specific array sections.

Step-by-step instructions for PV circuits

Before you arrive at the site, identify all circuits for testing and familiarize yourself with the inverter(s) and modules. Existing drawings provide the information that you need to properly prepare for the site visit. Based on the component ratings and system size, determine what the normal voltage readings would be if the system was operating without any faults. Establish equipment locations, the physical relationship between components, and both aboveground and belowground wire runs.

While testing, use a site map and sequential operation to maintain proper recordkeeping. Collecting data within the tools expedites the process. Still, you must be aware of the data collected and compare the expected values against the actual measurements that were taken in the field. To perform the following tests, you need a handheld digital multimeter (DMM) and potentially an insulation resistance tester. As a minimum for PPE, wear high-voltage safety gloves and safety glasses.

1. Document inverter error message

A ground fault message on the inverter(s) will be the initial alert that an error has occurred. Prior to any troubleshooting, technicians should record all error messages and error codes displayed by the inverter.

2. Document environmental conditions

As covered in detail in the chapters on **Voltage and Polarity** and **Current**, environmental conditions affect PV array performance. Specifically, it is critical that you measure module temperature, ambient temperature, humidity, and irradiance. Store all measurements for future reference.

Record the information that is displayed on the inverter or the ground-fault detection device. Check the onsite data acquisition system (DAS) to pinpoint the shutdown time, if available.

Lastly, perform a visual inspection. Walk through the affected area and document any signs of incomplete or improper installation or visible damage to any components.

3. Shut down and perform lockout/tagout (LOTO)

Place all solar equipment (inverters, DC disconnects, combiner boxes, etc.) in the open (off) position and use LOTO methods to maintain a safe working environment. When you are testing PV circuits, isolate the conductors from the modules to remove the voltage.

Before opening touch-safe fuse holders, use a multimeter to measure DC on all PV DC circuits. Faults in the wiring or miswired PV modules can result in current on conductors thought to have no current flow, even when the disconnects are in the open position. Pulling touch-safe fuse holders in these scenarios exposes you to shock and fire hazards.



Figure 13-17: Verify no current is flowing on DC circuits prior to opening touch-safe fuse-holders.

4. Isolate combiner-box inputs

If you are working on a large central inverter with multiple combiner-box inputs, isolate individual combiner boxes at the inverter to help identify the general location of a ground fault. One option is to remove all the combiner boxes from the inverter and to reset the ground-fault error. Then connect individual combiner boxes to the inverter to re-create a ground fault. This method helps identify the array section that has a fault and enables you to investigate further. Multiple ground faults may be present, so verify all combiner-box inputs.

Fusing to protect an inverter from ground faults is expensive and unreliable, given that the fuse blows each time a ground fault occurs. In those scenarios, an insulation resistance test (described in step 7) or the voltage measurement on individual combiner boxes may be more effective.

5. Isolate all PV source circuits

After you have identified the combiner box that contains the faulted conductor(s) or if the inverter uses an integrated string combiner box, you can test individual strings. All conductors must be isolated from each other. In the case of combiner boxes that have both positive and negative conductors connected to fuses, open the fuse holders to isolate each conductor. If positive or negative conductors land on a common bus bar, to test correctly, each string must be separated from all the others.

Warning!

Before you open fuse holders or remove conductors from bus bars, verify that there is no current flow in the conductors, as described in the [Current chapter](#).

6. Measure voltages

After all the strings have been isolated, take voltage measurements to help locate the ground fault. The ratio of the positive-to-ground and negative-to-ground readings helps to indicate the fault location.

For example, consider 10 modules that are connected in a series string where the open-circuit voltage (Voc) of each module is 50 volts (50 V). Since modules are in series, the system would normally expect to see 500 V on positive-to-negative. If the positive-to-ground voltage is 150 V DC and the negative-to-ground voltage is 350 V DC, you will find the ground fault between the third and fourth modules on the positive side of the string. This is determined by dividing the positive-to-ground voltage of 150 V by the module's open-circuit voltage of 50 V. Alternatively, suppose that the positive-to-ground reading is 0 V DC and the negative-to-ground voltage is 500 V DC. In that case, the fault location is the home run conductor in the positive conductor in the circuit.

Locating a ground fault in a PV string through voltage measurements

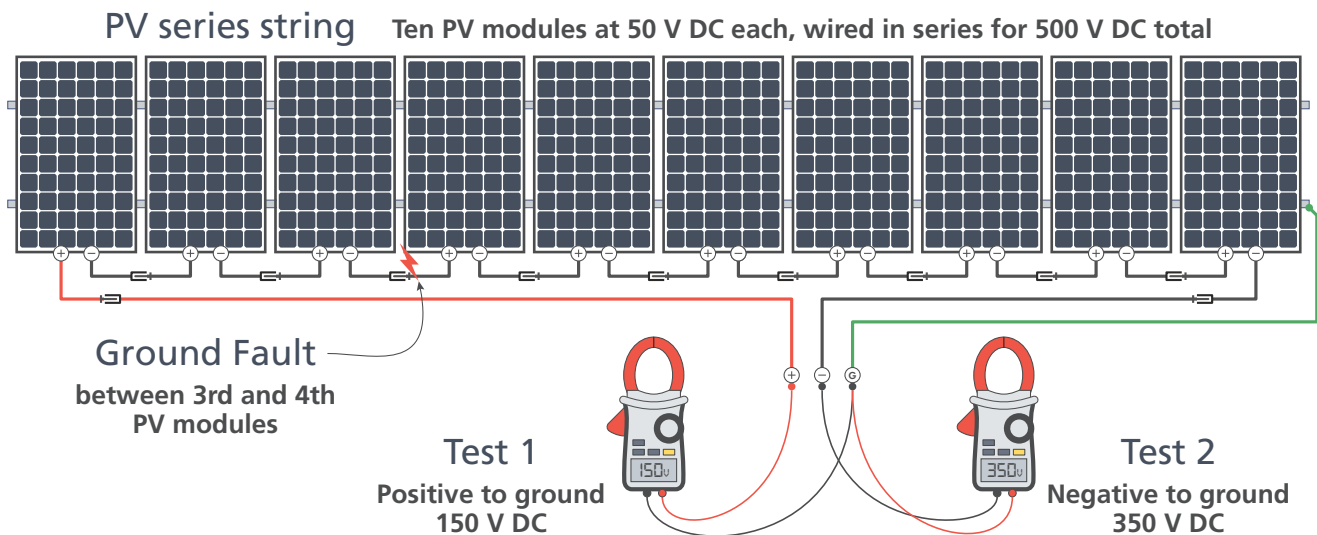

Figure 13-18: You can estimate the point within a PV string where a ground fault has occurred by using the rated Voc for the PV module and the voltage that you measured from positive to ground and negative to ground.

Inconclusive voltage reading can occur, in which case a technician will not be able to locate the fault. In these scenarios, utilise an insulation resistance test as described in Step 8 below.

7. Visually inspect isolated circuits

When voltage tests have narrowed down the potential fault location, visually inspect the region. Obvious signs of a ground fault include burned wiring, damaged modules, and signs of arcing on the racking.

8. Perform insulation resistance testing

If the fault location is still unclear after you have taken voltage measurements and inspected the area, insulation resistance tests can identify any damaged conductors. The **Insulation Resistance Testing** chapter describes insulation resistance testing procedures.

Insulation resistance tests apply DC voltage across the conductor that is under testing while injecting a small amount of current. The testing tool uses Ohm's Law to calculate the insulation resistance value from the known voltage and current. The minimum allowable resistance values are shown in the table below.

Test voltage and minimum resistance

System voltage ¹ (V DC)	Test voltage ² (V DC)	Minimum resistance (MΩ)
<120	250	0.5
120 – 240	500	1.0
>500	1000	1.0

Figure 13-19: Test voltage and minimum allowable resistance. System voltages are (Voc at standard test conditions [STC]) x 1.25. Test voltages are based on PV system Voc per IEC 62446.

Performing insulation resistance tests through PV modules

Ground faults, particularly intermittent ones, can be challenging to locate. In some cases, you might have to perform an insulation resistance test through the modules. Before you perform such a test, obtain approval from the module manufacturer. Some manufacturers have specific requirements to maintain warranties.

In general, when performed properly, the tests do not damage the modules. If the modules connect to DC-to-DC converters, consult with that manufacturer to verify the correct test method. In many cases, you must isolate the DC-to-DC converters from the circuit.

If the faults are intermittent, a wet test may be required. This test involves thoroughly wetting the array section that is under testing with a mixture of water and a surfactant (typically soap). A wet test can initiate a complete circuit by providing a current-carrying path (water) between the metallic component and the damaged conductor. Also, you may need to perform these tests after dark if the voltage that is produced by the modules exceeds the working voltage of the tester.

The results that you obtain from these tests can help you locate the circuits where ground faults have occurred. Do not use the values from the insulation resistance test to document the general health of the conductors. Depending on the humidity, the temperature, and dew or other moisture on the module surface, the insulation values may be significantly lower and may not indicate the overall insulation resistance.

9. Recommission the array

After the ground fault has been located and resolved, recommission the system and verify that no current is flowing in the EGC.

Page intentionally left blank.