

# EasyPlus UV/VIS

Easy UV/Easy VIS

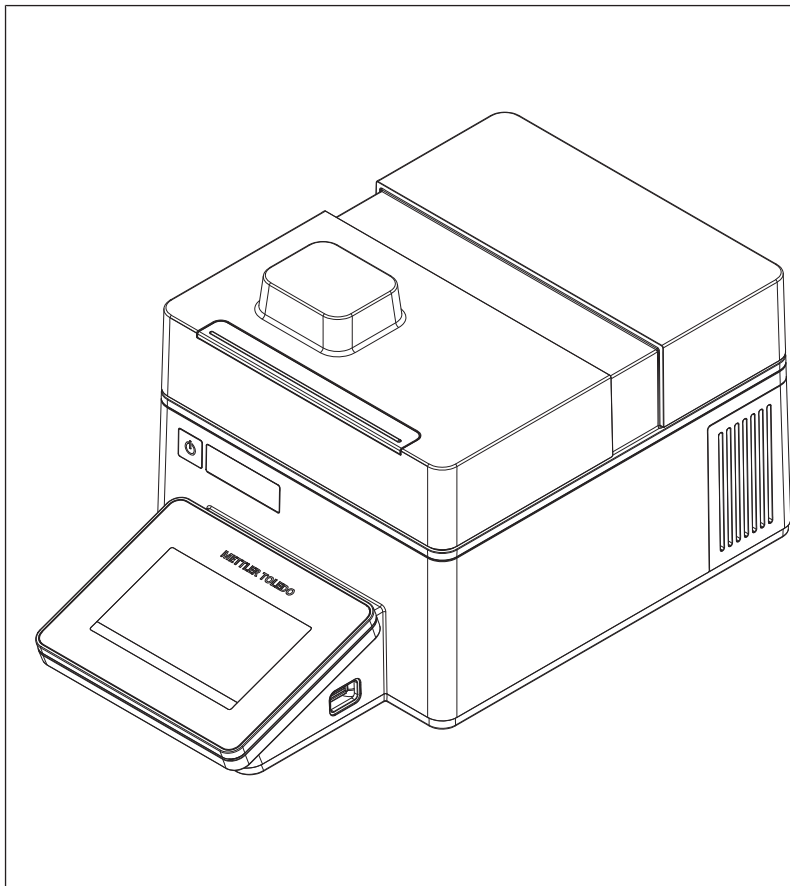

**METTLER TOLEDO**



# Table of Contents

<b>1</b>	<b>Introduction</b>	<b>3</b>
1.1	Further documents and information .....	3
1.2	Explanation of conventions and symbols .....	3
1.3	Compliance information .....	4
<b>2</b>	<b>Safety information</b>	<b>4</b>
2.1	Definitions of signal words and warning symbols .....	4
2.2	Product-specific safety notes .....	5
<b>3</b>	<b>Design and function</b>	<b>6</b>
3.1	Overview of the spectrophotometer .....	6
3.1.1	Top and bottom view .....	6
3.1.2	Rear panel .....	8
3.1.3	Analysis compartment .....	8
3.1.4	Cuvette carousels .....	9
3.1.5	Cuvettes and cuvette holders .....	10
3.2	Overview of home screen and functions .....	11
3.3	Menu structure .....	13
3.4	Overview of the measurement technology .....	14
3.4.1	Measurement principle .....	14
3.4.2	Scanning spectrophotometers .....	14
3.4.3	1-point background correction .....	16
<b>4</b>	<b>Installation</b>	<b>16</b>
4.1	Scope of delivery .....	16
4.2	Download the Reference Manual .....	17
4.3	Unpack the spectrophotometer .....	17
4.4	Position the spectrophotometer .....	18
4.5	Connect and disconnect the power supply .....	18
4.5.1	Connect the power supply .....	18
4.5.2	Disconnect the power supply .....	19
4.6	Configure the spectrophotometer .....	19
4.6.1	Change the language .....	19
4.6.2	Configure date and time .....	19
4.7	Install the cuvette carousel .....	20
4.8	Change the cuvette carousel .....	21
4.9	Install accessories .....	23
<b>5</b>	<b>Operation</b>	<b>23</b>
5.1	Start up the spectrophotometer .....	23
5.1.1	Start up the Easy VIS spectrophotometer .....	23
5.1.2	Start up the Easy UV spectrophotometer .....	25
5.2	Shut down the spectrophotometer .....	26
5.3	View parameter descriptions and tutorial .....	27
5.3.1	View parameter descriptions .....	27
5.3.2	Start and end the tutorial .....	27
5.4	Example: Determine the spectrum of fruit juice .....	28
5.4.1	Prepare the cuvettes .....	28
5.4.2	Prepare the spectrophotometer .....	29
5.4.3	Configure the scan method .....	30
5.4.4	Perform the analysis .....	32
<b>6</b>	<b>Maintenance</b>	<b>36</b>
6.1	Maintenance schedule .....	37

6.2	Clean the spectrophotometer .....	37
6.2.1	Clean glass or quartz cuvettes.....	38
6.2.2	Clean the housing.....	38
6.2.3	Clean the cuvette carousels.....	38
6.2.4	Clean the analysis compartment.....	39
6.2.5	Clean the storage compartment .....	39
6.2.6	Clean up spills .....	40
6.3	Perform adjustments .....	41
6.4	Replace parts .....	42
6.4.1	Replace the lamp (Easy VIS only).....	42
6.4.1.1	Remove the lamp (Easy VIS only) .....	42
6.4.1.2	Reinstall the lamp (Easy VIS only).....	43
6.4.1.3	Reset the lamp usage time (Easy VIS only).....	44
6.4.2	Replace the battery .....	44
6.5	Prepare the spectrophotometer for storage.....	45
6.6	Transport the spectrophotometer .....	46
6.7	Dispose of the spectrophotometer .....	46
<b>7</b>	<b>Troubleshooting</b> .....	<b>47</b>
7.1	Handle error messages.....	47
7.2	Request support.....	47
7.3	View the firmware version and other system information .....	48
<b>8</b>	<b>Technical data</b> .....	<b>48</b>
8.1	Spectrophotometer .....	48
8.2	Measurements .....	50

# 1 Introduction

Thank you for choosing a METTLER TOLEDO EasyPlus UV/VIS spectrophotometer. The EasyPlus UV/VIS spectrophotometer is an easy-to-operate instrument for measuring molecular absorbance or molecular transmittance of analytical samples.

The wavelength range depends on the instrument type.

- Easy UV: ultraviolet (UV) range and visible (VIS) range
- Easy VIS: visible (VIS) range

This document provides you with the information you need to get started with your METTLER TOLEDO EasyPlus UV/VIS spectrophotometer.

The instructions in this document refer to EasyPlus UV/VIS spectrophotometers running firmware version 1.0 or higher. The screenshots show the user interface of an Easy UV spectrophotometer.

The firmware license is subject to the End User License Agreement EULA. See the following link for the license text:

▶ [www.mt.com/EULA](http://www.mt.com/EULA)

## See also

🔗 View the firmware version and other system information ▶ Page 48

## 1.1 Further documents and information



For a full description of the spectrophotometer and its functions, refer to the Reference Manual, supplied as PDF file online. **See** [Download the Reference Manual ▶ Page 17].

For application notes, see the following links:

▶ [www.mt.com/library](http://www.mt.com/library)

▶ [www.mt.com/analytical-application-library](http://www.mt.com/analytical-application-library)

For third party licenses and open source attribution files, see the following link:

▶ [www.mt.com/licenses](http://www.mt.com/licenses)

If you have any additional questions, contact your authorized METTLER TOLEDO service representative or dealer.

▶ [www.mt.com/contact](http://www.mt.com/contact)

## 1.2 Explanation of conventions and symbols



Refers to an external document.

### Elements of instructions

Instructions always contain action steps and can contain prerequisites, intermediate results and results. If an instruction contains more than one action step, the action steps are numbered.

- Prerequisites that must be fulfilled before the individual action steps can be executed.

1 Action step 1

➔ Intermediate result

2 Action step 2

➔ Result

### 1.3 Compliance information

National approval documents, e.g., the FCC Supplier Declaration of Conformity, are available online and/or included in the packaging.

► [www.mt.com/ComplianceSearch](http://www.mt.com/ComplianceSearch)

Application-relevant standards and norms are listed on the internet.

► <http://www.mt.com/uvvis-water-test>

► <http://www.mt.com/uvvis-color>

Contact METTLER TOLEDO for questions about the country-specific compliance of your instrument.

► [www.mt.com/contact](http://www.mt.com/contact)

#### European Union

The instrument complies with the directives and standards listed on the EU Declaration of Conformity.

#### United States of America

This equipment has been tested and found to comply with the limits for a **Class A** digital device, pursuant to part 15 of the FCC Rules. These limits are designed to provide reasonable protection against harmful interference when the equipment is operated in a commercial environment. This equipment generates, uses, and can radiate radio frequency energy and, if not installed and used in accordance with the instruction manual, may cause harmful interference to radio communications. Operation of this equipment in a residential area is likely to cause harmful interference in which case the user will be required to correct the interference at his own expense.

Changes or modifications not expressly approved by the party responsible for compliance could void the user's authority to operate the equipment.

#### Trademarks

Trademark	Trademark owner
LongClick™	Mettler-Toledo GmbH, Greifensee, Switzerland
SQKitReader™	Mettler-Toledo GmbH, Greifensee, Switzerland
XPathHolder™	Mettler-Toledo GmbH, Greifensee, Switzerland
Spectroquant®	Merck KGaA, Darmstadt, Germany

## 2 Safety information

Two documents named "User Manual" and "Reference Manual" are available for this instrument.

- The User Manual is printed and delivered with the instrument.
- The electronic Reference Manual contains a full description of the instrument and its use.
- Keep both documents for future reference.
- Include both documents if you transfer the instrument to other parties.

Only use the instrument according to the User Manual and the Reference Manual. If you do not use the instrument according to these documents or if the instrument is modified, the safety of the instrument may be impaired and Mettler-Toledo GmbH assumes no liability.



User Manual and Reference Manual are available online. See [Download the Reference Manual ► Page 17].

### 2.1 Definitions of signal words and warning symbols

Safety notes contain important information on safety issues. Ignoring the safety notes may lead to personal injury, damage to the instrument, malfunctions and false results. Safety notes are marked with the following signal words and warning symbols:

## Signal words

- WARNING** A hazardous situation with medium risk, possibly resulting in death or severe injury if not avoided.
- CAUTION** A hazardous situation with low risk, resulting in minor or moderate injury if not avoided.
- NOTICE** A hazardous situation with low risk, resulting in damage to the instrument, other material damage, malfunctions and erroneous results, or loss of data.

## Warning symbols



General hazard: read the User Manual or the Reference Manual for information about the hazards and the resulting measures.



Hot surface



Notice

## 2.2 Product-specific safety notes

### Intended use

The spectrophotometers Easy UV and Easy VIS are designed to be used by trained staff.

- The Easy UV spectrophotometer is suitable for measuring absorbance or transmittance in the ultra-violet (UV) range and the visible (VIS) range of analytical samples.
- The Easy VIS spectrophotometer is suitable for measuring absorbance or transmittance in the visible (VIS) range of analytical samples.

The spectrophotometers are suitable for samples with the following characteristics:

- Compatible with the materials they come into contact with
- Free of air bubbles
- In thermal equilibrium with the environment

Any other type of use and operation beyond the limits of use stated by Mettler-Toledo GmbH without consent from Mettler-Toledo GmbH is considered as not intended.

### Responsibilities of the instrument owner

The instrument owner is the person holding the legal title to the instrument and who uses the instrument or authorizes any person to use it, or the person who is deemed by law to be the operator of the instrument. The instrument owner is responsible for the safety of all users of the instrument and third parties.

Mettler-Toledo GmbH assumes that the instrument owner trains users to safely use the instrument in their workplace and deal with potential hazards. Mettler-Toledo GmbH assumes that the instrument owner provides the necessary protective gear.

### Safety notes



#### **WARNING**

##### **Death or serious injury due to electric shock**

Contact with parts that carry a live current can lead to death or injury.

- 1 Only use the METTLER TOLEDO power cable and AC/DC adapter designed for your instrument.
- 2 Connect the power cable to a grounded power outlet.
- 3 Keep all electrical cables and connections away from liquids and moisture.
- 4 Check the cables and the power plug for damage and replace them if damaged.



## Bottom view

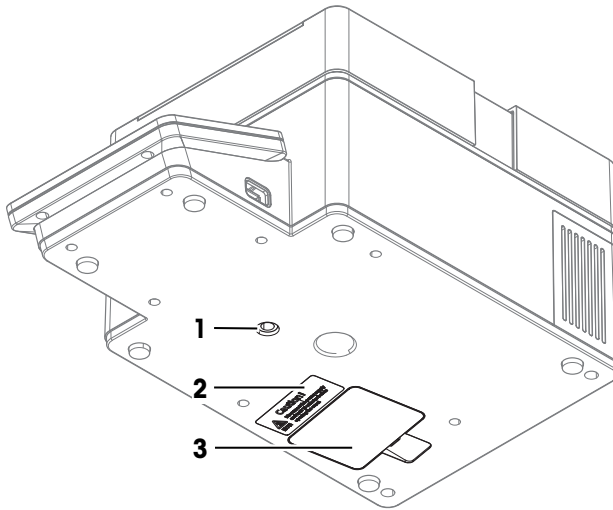

No.	Name	Function
1	Drain hole	Drainage hole for liquids spilled inside the spectrophotometer
2	Safety label (Easy VIS only)	Warns that the light bulb can be hot and cause burns
3	Lamp and battery compartment	Access point to replace the following parts: <ul style="list-style-type: none"><li>• Battery</li><li>• Lamp (Easy VIS only)</li></ul>

### See also

- [Maintenance](#) ▶ Page 36
- [Technical data](#) ▶ Page 48

### 3.1.2 Rear panel

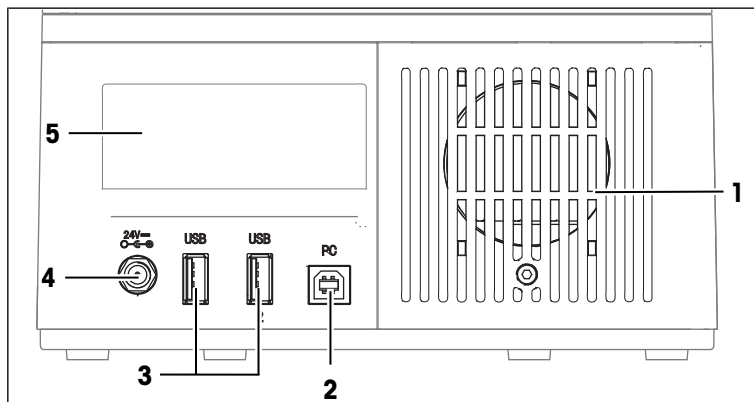

No.	Name	Function
1	Vent	Air outlet for cooling the spectrophotometer
2	PC	USB-B socket to connect a computer
3	USB 1/USB 2	USB-A socket to connect USB devices, for example printers or barcode readers
4	24V	DC socket to connect the AC/DC adapter
5	Type label	Shows important information about the spectrophotometer

#### See also

[Maintenance](#) ▶ Page 36

[Technical data](#) ▶ Page 48

### 3.1.3 Analysis compartment

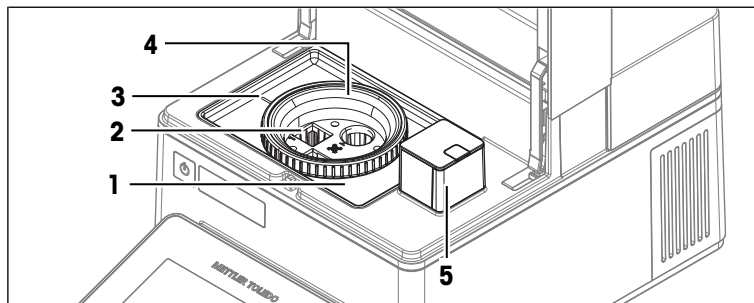

No.	Name	Function
1	Drip tray	Protects internal components from spillage
2	Measurement position	Position for cuvette during measurement
3	Mark	Mark for aligning cuvette carousel dot with the measurement position
4	Cuvette carousel	Cuvette carousel with cuvette holders for specific cuvette types

No.	Name	Function
5	Internal barcode reader (optional accessory)	Reads 2D barcodes of water test kits, for example Spectroquant®

#### See also

- 🔗 Cuvette carousels ▶ Page 9
- 🔗 Cuvettes and cuvette holders ▶ Page 10
- 🔗 Maintenance ▶ Page 36
- 🔗 Technical data ▶ Page 48

### 3.1.4 Cuvette carousels

There are three cuvette carousels that can be used with the spectrophotometer:

- Cuvette carousel 10/16
- Cuvette carousel 20/30
- Cuvette carousel 40/50/1

Each carousel has cuvette holders intended for use with specific cuvette types. Only one carousel can be installed in the analysis compartment at a time.

#### Cuvette carousel overview

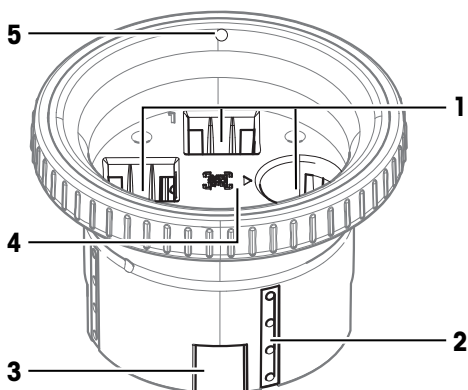

No.	Name	Function
1	Cuvette holders	For placement of cuvettes in the cuvette carousel
2	Position magnet	Spectrophotometer detects magnets to determine which cuvette holder is in the measurement position
3	Light beam opening	Four cutouts in cuvette carousel allow the light beam to pass through sample
4	Barcode symbol and triangle	Symbols to align the 2D barcodes of water test kits
5	Dot	Dot for aligning the cuvette holder with the measurement position mark

## Cuvette carousel specifications

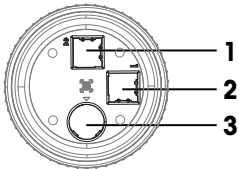
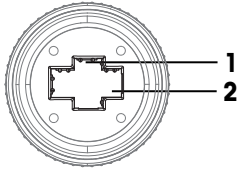
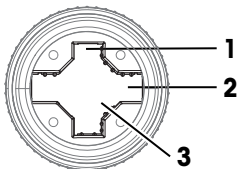
Name	Top view	Cuvette holders
Cuvette carousel 10/16		<b>1:</b> 10 mm cuvette holder <b>2:</b> 10 mm cuvette holder <b>3:</b> Ø16 mm cuvette holder
Cuvette carousel 20/30		<b>1:</b> 20 mm cuvette holder <b>2:</b> 30 mm cuvette holder
Cuvette carousel 40/50/1		<b>1:</b> 40 mm cuvette holder <b>2:</b> 50 mm cuvette holder <b>3:</b> 1 inch cuvette holder

### See also

- 🔗 Cuvettes and cuvette holders ▶ Page 10
- 🔗 Install the cuvette carousel ▶ Page 20
- 🔗 Change the cuvette carousel ▶ Page 21
- 🔗 Maintenance ▶ Page 36
- 🔗 Technical data ▶ Page 48

### 3.1.5 Cuvettes and cuvette holders

Cuvettes must conform to the following guidelines:

- Only use macro cuvettes designed for use with spectrophotometers that have a Z height of 8.5 mm.
- Only use macro cuvettes because they have an optical window larger than the light beam.
- Only use flat-bottomed macro cuvettes.

The cuvette holders in each carousel accommodate specific cuvette types and path lengths. When analyzing samples, observe the following recommendations for cuvette use:

- Only use liquid blank solutions and samples for analysis.
- Use a cuvette cover when analyzing volatile or combustible samples.
- If present, only handle the frosted sides of cuvettes.
- Do not handle the clear sides of cuvettes.
- Only load cuvettes with the same width/diameter as the cuvette holder.

For questions regarding the use of micro cuvettes, contact your authorized METTLER TOLEDO service representative or dealer.

► [www.mt.com/contact](http://www.mt.com/contact)

The following tables list the cuvette types that can be used with the cuvette holders in each cuvette carousel.

#### **Cuvette carousel 10/16**

<b>Cuvette holder</b>	<b>Cuvette types</b>
10 mm	0.1 mm optical path length macro cuvette
	0.2 mm optical path length macro cuvette
	0.5 mm optical path length macro cuvette
	1 mm optical path length macro cuvette
	2 mm optical path length macro cuvette
	5 mm optical path length macro cuvette
	10 mm optical path length macro cuvette
Ø16 mm	Glass tube: <ul style="list-style-type: none"><li>• 13.6 mm optical path length</li><li>• 16 mm outer diameter</li><li>• Flat bottom</li></ul>

#### **Cuvette carousel 20/30**

<b>Cuvette holder</b>	<b>Cuvette type</b>
20 mm	20 mm optical path length macro cuvette
30 mm	30 mm optical path length macro cuvette

#### **Cuvette carousel 40/50/1**

<b>Cuvette holder</b>	<b>Cuvette type</b>
40 mm	40 mm optical path length macro cuvette
50 mm	50 mm optical path length macro cuvette
1 inch	1 inch optical path length macro cuvette

#### **See also**



- 🔗 Cuvette carousels ► Page 9
- 🔗 Prepare the cuvettes ► Page 28
- 🔗 Maintenance ► Page 36
- 🔗 Technical data ► Page 48

### **3.2 Overview of home screen and functions**

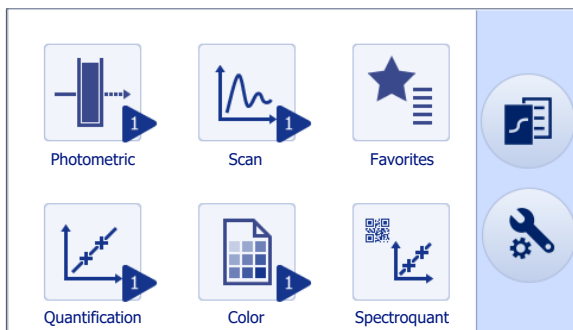
EasyPlus spectrophotometers perform optical spectroscopy and differ in their wavelength range. Measurements generate raw results that are provided as absorbance or percent transmittance. Depending on the method type, these raw results can be converted to other physical quantities like concentrations.









Icon	Name	Description
	<b>Photometric</b>	Configure and start a photometric method. Up to 20 methods can be configured. Absorbance, transmittance or both are measured at up to five specific wavelengths.
	<b>Scan</b>	Configure and start a scan method. Up to 20 methods can be configured. Absorbance or transmittance is measured as a function of wavelength. The results are provided as a spectrum.
	<b>Favorites</b>	Configure and start frequently used methods.
	<b>Quantification</b>	Configure and start a quantification method. Up to 20 methods can be configured. Absorbance or transmittance is measured at specific wavelengths. These raw results are converted to a desired result using either a formula or a calibration curve. <ul style="list-style-type: none"> <li>• Formula: The spectrophotometer uses a mathematical formula that is defined by the user to calculate the desired result.</li> <li>• Calibration curve: The spectrophotometer creates a calibration curve based on the measurements of a range of standard solutions. Based on this calibration curve, the spectrophotometer calculates the concentrations of samples.</li> </ul>
	<b>Color</b>	Configure and start a color method. Up to 20 methods can be configured. Absorbance or transmittance are measured. These raw results are converted to a color value according to the selected color scale.
	<b>Spectroquant</b> (with SQKitReader only)	Start Spectroquant® methods for water test kits. Absorbance is measured at specific wavelengths. These raw results are converted to the concentration of the analyte of the sample. The conversion is based on a mathematical formula, which is defined by the Spectroquant® test kit.
	<b>Results</b>	Access and manage the results of the last 100 analyses.

















Icon	Name	Description
	<b>Setup &amp; Tools</b>	<p>Access the following functions:</p> <ul style="list-style-type: none"> <li>• <b>Settings:</b> change instrument settings.</li> <li>• <b>Language:</b> change the language of the user interface.</li> <li>• <b>Diagnostics:</b> run diagnostics.</li> <li>• <b>Toolbox:</b> update the firmware, restore factory settings, access tutorial and service information.</li> <li>• <b>Adjustment:</b> run adjustment methods to restore spectrophotometer performance: <ul style="list-style-type: none"> <li>– Dark current correction of the two photosensors for accurate optical measurements (Easy VIS only).</li> <li>– System baseline correction for accurate optical measurements.</li> </ul> </li> <li>• <b>Spectroquant</b> (with SQKitReader only): change settings that apply to all Spectroquant® methods.</li> </ul>
	LongClick	<p>Tap and hold the icon of one of the following apps to start the last performed method.</p> <p>: The number in the triangle shows the method index of the last used method of the method type.</p> <ul style="list-style-type: none"> <li>• <b>Photometric</b></li> <li>• <b>Scan</b></li> <li>• <b>Quantification</b></li> <li>• <b>Color</b></li> </ul>

#### See also



- [Overview of the measurement technology](#) ▶ Page 14
- [Example: Determine the spectrum of fruit juice](#) ▶ Page 28

### 3.3 Menu structure

	<b>Photometric</b>
	<b>Scan</b>
	<b>Favorites</b>
	<b>Quantification</b>
	<b>Color</b>
	<b>Spectroquant</b> (with SQKitReader only)
	<b>Results</b>

 <b>Setup &amp; Tools</b>	 <b>Settings</b>
	 <b>Language</b>
	 <b>Adjustment</b>
 <b>Diagnostics</b>	 <b>Peripheral check</b>
	 <b>Printer check</b>
	 <b>Performance test</b>
 <b>Toolbox</b>	 <b>Factory Reset</b>
	 <b>FW update</b>
	 <b>EasySetup Tutorial</b>
	 <b>MT-Service</b>
	 <b>Service history</b>
	 <b>Settings</b>
 <b>Spectroquant</b> (with SQKitReader only)	

#### See also

-  [Configure the spectrophotometer](#) ▶ Page 19
-  [View parameter descriptions](#) ▶ Page 27

## 3.4 Overview of the measurement technology

### 3.4.1 Measurement principle

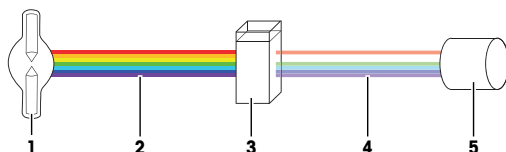

The lamp (1) emits light (2) with a known spectrum and a defined intensity. This light passes through the sample and the cuvette (3). The sample and the cuvette absorb some of the light. The optical sensor (5) measures the intensity of remaining light (4).

This light intensity is not the final result. In addition to the sample, the solvent and the cuvette also absorb light. To correct for the absorption of the solvent and the cuvette, a blank solution needs to be measured. The blank solution is typically the solvent used to dissolve the sample.

#### See also

-  [Technical data](#) ▶ Page 48

### 3.4.2 Scanning spectrophotometers

EasyPlus UV/VIS spectrophotometers are based on a scanning setup. In scanning spectrophotometers, consecutive measurements of the transmittance value at individual wavelengths are recorded.

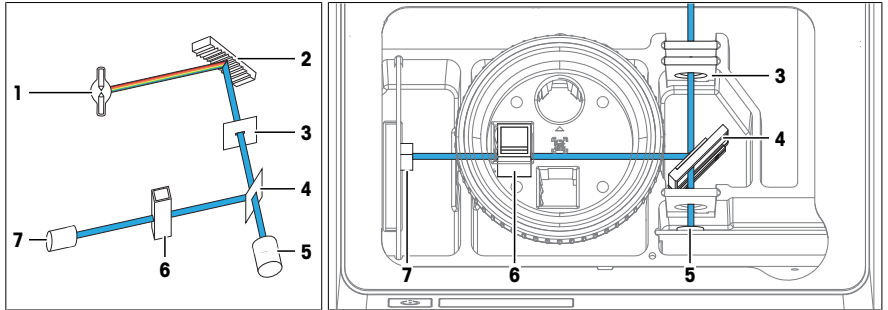

A grating separates the light from the lamp into different wavelengths. Only one wavelength at a time can pass through the exit slit. The transmittance at this wavelength is recorded. Then the grating rotates and a different wavelength passes through the exit slit. The whole spectrum is obtained by combining the measurements at the different wavelengths.



No.	Name	Function
1	Lamp	Emits light
2	Rotating grating	Separates the light beam into the different wavelengths and changes the exit angle of the light beam
3	Exit slit	Only lets one wavelength pass
4	Beam splitter	Splits the light beam into two beams, the reference light-beam and the sample light-beam
5	Optical sensor for reference light-beam	Records the transmittance of the reference light-beam
6	Sample	Absorbs light at specific wavelengths
7	Optical sensor for sample light-beam	Records the transmittance of the sample light-beam after it passed through the sample

EasyPlus UV/VIS spectrophotometers use dual beam technology. When the light beam passes through the exit slit, a beam splitter separates the light beam into two light beams: a reference light-beam and a sample light-beam. The reference light-beam continues to an optical sensor that measures the reference value. The sample light-beam path continues through the sample cuvette, a lens and onto another optical sensor that records the spectrum.

#### See also

-  [Analysis compartment](#) ▶ Page 8
-  [Cuvettes and cuvette holders](#) ▶ Page 10
-  [Install the cuvette carousel](#) ▶ Page 20

### 3.4.3 1-point background correction



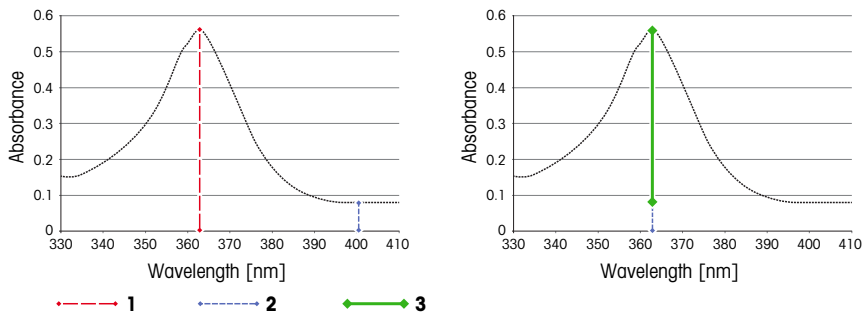

The absorbance at a reference wavelength is used to correct the result.





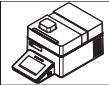

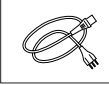
No.	Symbol	Explanation
1	$A(\lambda)$	Absorbance of the sample without background correction
2	$A(\lambda_{Ref1})$	Absorbance at the wavelength used for the background correction
3	$A(\lambda, \lambda_{Ref1})$	Corrected absorbance: $A(\lambda, \lambda_{Ref1}) = A(\lambda) - A(\lambda_{Ref1})$

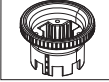
## 4 Installation

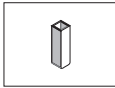
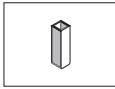
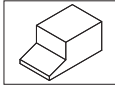
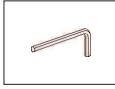
### 4.1 Scope of delivery

Part	Order number	Easy UV	Easy VIS
 Spectrophotometer	–	•	•
 AC adapter with power cable	30472916	•	•
 Power cable Country specific	–	•	•
 XPathHolder cuvette carousel 10/16	30705122	•	•
 XPathHolder cuvette carousel 20/30	30705123	•	•
 XPathHolder cuvette carousel 40/50/1	30705124	•	•

Part	Order number	Easy UV	Easy VIS
 Cuvette Standard Q Quartz Glass 10 mm (2 pcs)	30675051	•	–
 Cuvette Standard O Optical Glass 10 mm (2 pcs)	30675053	–	•
 Dust cover	–	•	•
 Allen wrench	–	•	•
 User Manual	–	•	•
 Declaration of conformity	–	•	•
 Test report	–	•	•

## 4.2 Download the Reference Manual

- 1 Go to the website [www.mt.com/library](http://www.mt.com/library).
- 2 Select the **Technical Documentation** tab.
- 3 Find the product type on the housing of the spectrophotometer and enter it into the search field.
- 4 Start the search.
- 5 Select the Reference Manual from the result list.
- 6 Select the link.
  - ➔ The Reference Manual is either opened or downloaded depending on the browser settings.
- 7 Check which firmware version is installed on your spectrophotometer.
- 8 If the manual is not written for the installed firmware version, contact your authorized METTLER TOLEDO service representative or dealer.

► [www.mt.com/contact](http://www.mt.com/contact)

## 4.3 Unpack the spectrophotometer

- 1 Remove the spectrophotometer from the protective packaging.
- 2 Store the protective packaging for later transport over long distances.
- 3 Check that you have received all parts listed in the scope of delivery.
- 4 Inspect the parts visually for flaws or damage.
- 5 If parts are missing or damaged, report it to your authorized METTLER TOLEDO service representative or dealer.

► [www.mt.com/contact](http://www.mt.com/contact)

## See also

🔗 Scope of delivery ▶ Page 16

## 4.4 Position the spectrophotometer

The spectrophotometer has been developed for indoor operation in a well-ventilated area.

The following site requirements apply:

- Ambient conditions within the limits specified in the technical data
- No powerful vibrations
- No direct sunlight
- No corrosive gas atmosphere
- No explosive atmosphere
- No powerful electric or magnetic fields

### Procedure

- 1 Place the spectrophotometer on a level surface.
- 2 Make sure that there are at least 15 cm clearance at the back of the spectrophotometer.
- 3 Make sure that nothing blocks the ventilation openings at the back of the spectrophotometer.

## See also

🔗 Technical data ▶ Page 48

## 4.5 Connect and disconnect the power supply

### 4.5.1 Connect the power supply

The AC/DC adapter is suitable for all supply line voltages ranging from 100...240 V AC and 50-60 Hz.



### ⚠️ WARNING

#### Death or serious injury due to electric shock

Contact with parts that carry a live current can lead to death or injury.

- 1 Only use the METTLER TOLEDO power cable and AC/DC adapter designed for your instrument.
- 2 Connect the power cable to a grounded power outlet.
- 3 Keep all electrical cables and connections away from liquids and moisture.
- 4 Check the cables and the power plug for damage and replace them if damaged.



### NOTICE

#### Damage to the AC/DC adapter due to overheating

An AC/DC adapter that does not have adequate air circulation around it, cannot cool sufficiently and overheats.

- Do not cover the AC/DC adapter.

### Procedure

- 1 Install the cables in such a way that they cannot be damaged or interfere with operation.
- 2 Insert the plug of the power cable into the socket of the AC/DC adapter.

- 3 Insert the plug of the AC/DC adapter into the **24V** socket (1) on the rear panel.
- 4 Tighten the knurled nut to secure the plug.
- 5 Insert the plug of the power cable into a grounded power outlet that is easily accessible.

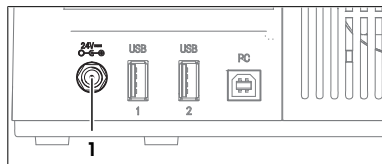

**See also**

- 🔗 Rear panel ▶ Page 8
- 🔗 Start up the spectrophotometer ▶ Page 23

**4.5.2 Disconnect the power supply**

- The spectrophotometer is shut down.

  - 1 Pull the plug of the power cable out of the power outlet.
  - 2 Loosen the knurled nut.
  - 3 Pull the plug of the AC/DC adapter out of the **24V** socket on the rear panel.

**See also**

- 🔗 Rear panel ▶ Page 8
- 🔗 Shut down the spectrophotometer ▶ Page 26

**4.6 Configure the spectrophotometer**

**4.6.1 Change the language**

- 1 Go to (1) > .
- 2 Tap **Language** and select the language from the list.
  - ➔ The selected language is used on the touch screen and printouts.
- 3 To return to **Setup & Tools**, tap .
- 4 To return to the home screen, tap .

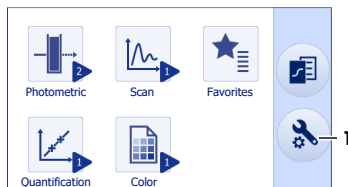

**See also**

- 🔗 Overview of home screen and functions ▶ Page 11
- 🔗 View parameter descriptions ▶ Page 27

**4.6.2 Configure date and time**

This chapter shows you how to access and change the following settings:

- Date and time formats
- Date/time



Read the Reference Manual of the spectrophotometer for a description of all instrument settings.

**See** [Download the Reference Manual ▶ Page 17].

You can find parameter descriptions in the help embedded on the instrument. **See** [View parameter descriptions ▶ Page 27].



## Procedure

1 Go to  (1) >  .

2 Select **Settings** (1).

3 Change the parameters as needed.

4 To display parameter descriptions, tap  (2).

5 To return to the home screen, go to  (3) > .

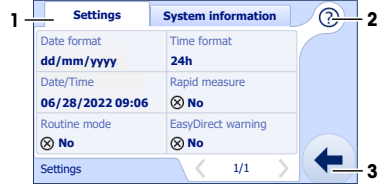
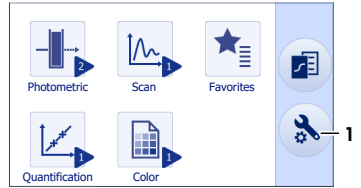

## See also

 Overview of home screen and functions ▶ Page 11

 View parameter descriptions ▶ Page 27

## 4.7 Install the cuvette carousel

To perform measurements, a cuvette carousel must be properly installed in the drip tray in the analysis compartment. Each carousel has a dot above each cuvette holder. When installing a cuvette carousel, the dot must be aligned with the mark on the drip tray for proper positioning of the desired cuvette holder in the measurement position.

1 Press down on the lid (1) to open the analysis compartment.

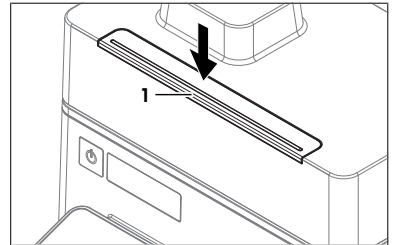

2 Insert the cuvette carousel (1) into the drip tray (2).

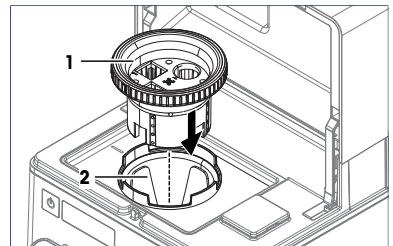

- 3 Rotate the cuvette carousel (2) to align the cuvette holder dot (1) with the measurement position mark (3).  
➔ The positioning pin snaps into the positioning groove when the cuvette holder is properly aligned.

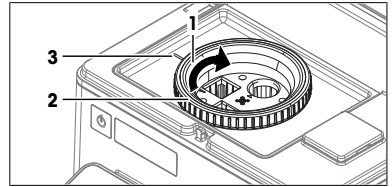

**See also**

- 🔗 Analysis compartment ▶ Page 8
- 🔗 Cuvette carousels ▶ Page 9
- 🔗 Cuvettes and cuvette holders ▶ Page 10

#### 4.8 Change the cuvette carousel

- 1 Press down on the lid (1) to open the analysis compartment.

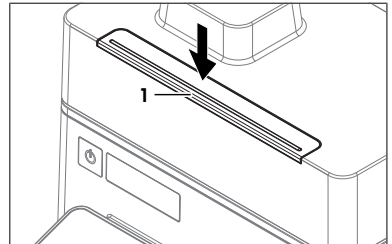

- 2 Slightly turn the cuvette carousel (1) and lift it out of the drip tray.

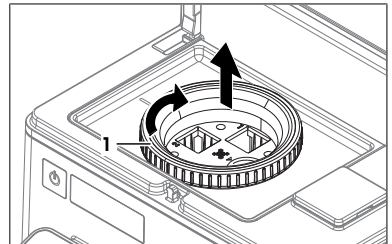

- 3 Lift the back cover (1) of the storage compartment.

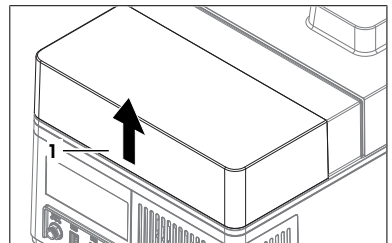

- 4 Lift the cuvette carousel out of the cuvette carousel bay.

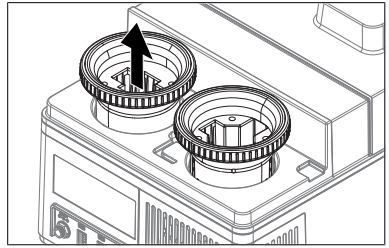

- 5 Insert the cuvette carousel (1) into the drip tray (2).

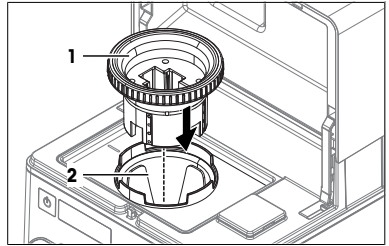

- 6 Insert the previously installed cuvette carousel (1) into the empty cuvette carousel bay (2).

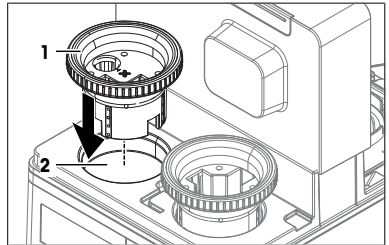

- 7 Align the back cover (1) with the magnet notches (2).
- 8 Lower the back cover (1) onto the storage compartment.

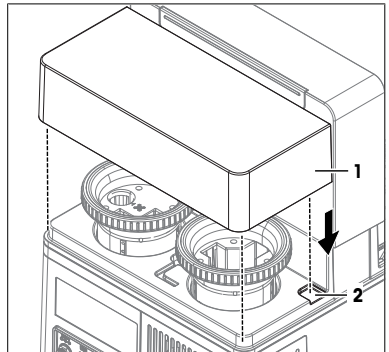

**See also**

- 🔗 Cuvette carousels ▶ Page 9
- 🔗 Analysis compartment ▶ Page 8
- 🔗 Install the cuvette carousel ▶ Page 20

## 4.9 Install accessories



Read the Reference Manual for more information on how to set up accessories. See [Download the Reference Manual ▶ Page 17].

## 5 Operation

### 5.1 Start up the spectrophotometer

#### Initial adjustment

The first time the spectrophotometer is started up, adjustment is required to ensure measurement accuracy. If adjustment is not performed upon first-time startup, measurement results may be unreliable.

The spectrophotometer must be running and warmed up for at least one hour prior to performing adjustment.

Available adjustment methods for each instrument are:

- Easy UV: system baseline
- Easy VIS: system baseline and dark current

#### See also

- 🔗 Connect the power supply ▶ Page 18
- 🔗 Perform adjustments ▶ Page 41

#### 5.1.1 Start up the Easy VIS spectrophotometer

##### First-time startup

When the spectrophotometer is started up for the first time, you will need to select the language from the menu. After initialization, the EasySetup Tutorial dialog will open. The EasySetup Tutorial dialog only opens during first-time startup, but can be accessed later from the toolbox.

##### Initialization

Upon start up, the spectrophotometer will perform a series of initialization and calibration self-tests that require approximately two minutes. Do not open the lid during this process.

##### Warm-up phase

When initialization is complete, a 20-minute warm-up phase is necessary to ensure measurement accuracy. A pop-up timer opens for monitoring the warm-up phase. The pop-up timer can be closed, but do not take measurements until the 20-minute warm-up phase is complete.

##### Procedure

- 1 Press the power button (1).

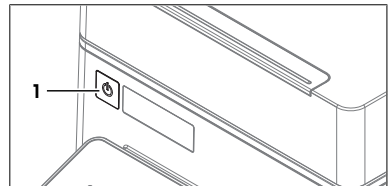

- ➔ First-time startup: You are prompted to select the language.

- 2 If prompted, select the language and tap **OK** (1).

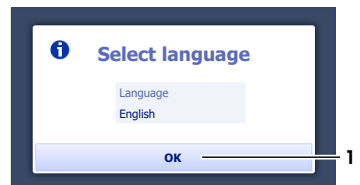

- ➔ You are prompted to confirm that the light beam is not blocked and the lid is closed.

3 Tap **Continue** (1).

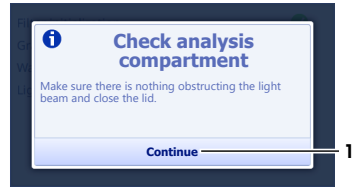

4 Press down on the lid (1) to open the analysis compartment.

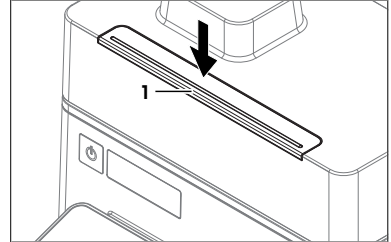

5 Rotate the cuvette carousel (2) to align the cuvette holder dot (1) with the measurement position mark (3).

- ➔ The positioning pin snaps into the positioning groove when the cuvette holder is properly aligned.

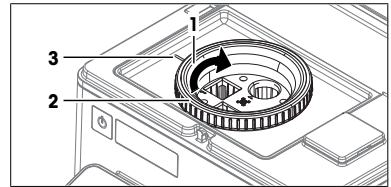

6 Make sure the cuvette holder in the measurement position (1) is empty.

7 Close the lid.

- ➔ The spectrophotometer performs self-tests and detects connected devices.

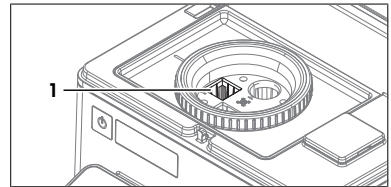

- ➔ First-time startup: You can choose to run the tutorial.

8 If prompted, select **Continue** (1) to open the tutorial or **Cancel** (2) to close it.

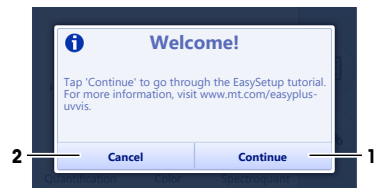

- ➔ The pop-up timer opens.

➔ The spectrophotometer is ready for use after 20 minutes when the home screen opens.

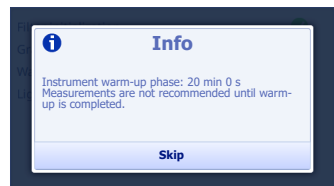

### See also

- 🔗 Connect the power supply ▶ Page 18
- 🔗 Change the language ▶ Page 19
- 🔗 Install the cuvette carousel ▶ Page 20
- 🔗 Change the cuvette carousel ▶ Page 21
- 🔗 Start and end the tutorial ▶ Page 27
- 🔗 Perform adjustments ▶ Page 41

## 5.1.2 Start up the Easy UV spectrophotometer

### First-time startup

When the spectrophotometer is started up for the first time, you will need to select the language from the menu. After initialization, the EasySetup Tutorial dialog will open. The EasySetup Tutorial dialog only opens during first-time startup, but can be accessed later from the toolbox.

### Initialization

Upon start up, the spectrophotometer will perform a series of initialization and calibration self-tests that require approximately two minutes. Do not open the lid during this process.

### Procedure

- 1 Press the power button (1).

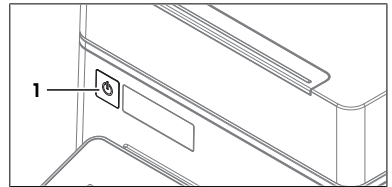

➔ First-time startup: You are prompted to select the language.

- 2 If prompted, select the language and tap **OK** (1).

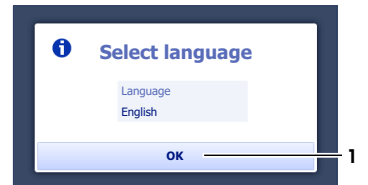

➔ You are prompted to confirm that the light beam is not blocked and the lid is closed.

- 3 Tap **Continue** (1).

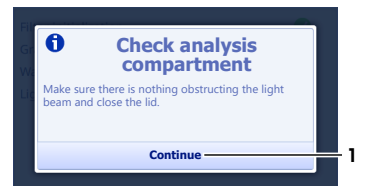

- 4 Press down on the lid (1) to open the analysis compartment.

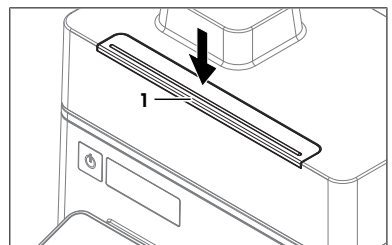

- 5 Rotate the cuvette carousel (2) to align the cuvette holder dot (1) with the measurement position mark (3).
  - ➔ The positioning pin snaps into the positioning groove when the cuvette holder is properly aligned.

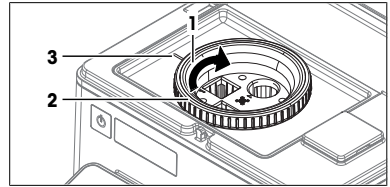

- 6 Make sure the cuvette holder in the measurement position (1) is empty.
- 7 Close the lid.
  - ➔ The spectrophotometer performs self-tests and detects connected devices.

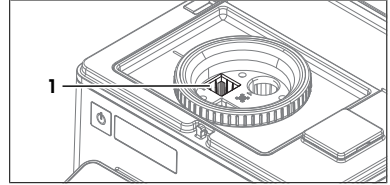

- ➔ First-time startup: You can choose to run the tutorial.
- 8 If prompted, select **Continue** (1) to open the tutorial or **Cancel** (2) to close it.
    - ➔ The spectrophotometer is ready for use when the home screen opens.

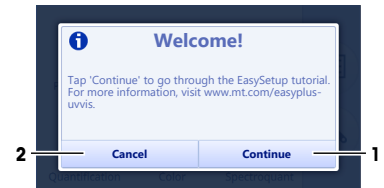

### See also

- 🔗 Connect the power supply ▶ Page 18
- 🔗 Change the language ▶ Page 19
- 🔗 Install the cuvette carousel ▶ Page 20
- 🔗 Change the cuvette carousel ▶ Page 21
- 🔗 Start and end the tutorial ▶ Page 27
- 🔗 Perform adjustments ▶ Page 41

## 5.2 Shut down the spectrophotometer

- Press the power button for 3 s.
  - ➔ The spectrophotometer stops running tasks.
  - ➔ The shut down screen will be displayed while history and data are saved.
  - ➔ The touch screen turns off and the power shuts down.
- ➔ The AC/DC adapter and the control circuit for the power button are energized. The rest of the spectrophotometer is no longer energized.

### Shutdown of the spectrophotometer in emergency situations

- Pull the plug of the power cable out of the power outlet.

### See also

- 🔗 Disconnect the power supply ▶ Page 19

## 5.3 View parameter descriptions and tutorial

### 5.3.1 View parameter descriptions

1 Go to  (1) > .

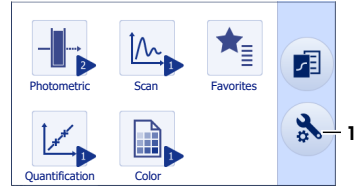

2 Tap  (1).



3 Tap the parameter (2) that interests you.

➔ A window with the help text opens.



4 Close the window.

5 Tap  (1) to close the help text.

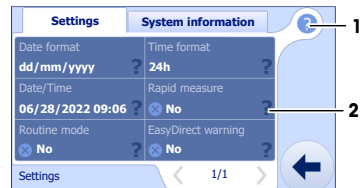
6 To return to the home screen, tap  and then .



#### See also



-  Overview of home screen and functions ▶ Page 11
-  Configure the spectrophotometer ▶ Page 19
-  Example: Determine the spectrum of fruit juice ▶ Page 28

### 5.3.2 Start and end the tutorial

The EasySetup Tutorial consists of seven sections:

1. Define settings
2. Install cuvette carousel and position cuvette holder
3. Change cuvette carousel
4. Measurement methods
5. Options for starting a method
6. Online help and perform photometric measurement
7. Tips for using the spectrophotometer

#### Procedure

1 To start the tutorial, tap  (1) >  > .

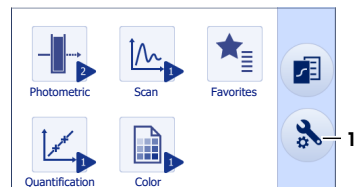

- 2 To proceed through the tutorial windows, tap ➔ (2).
- 3 To open a specific tutorial window, select a number (1).
- 4 To exit the tutorial at any point, tap 🏠 (3).

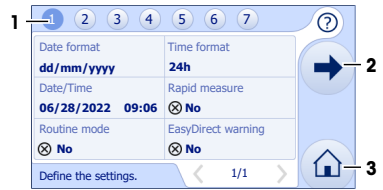

### See also

- 🔗 Overview of home screen and functions ▶ Page 11
- 🔗 Start up the spectrophotometer ▶ Page 23

## 5.4 Example: Determine the spectrum of fruit juice

The example shows how to use the scan method to determine the spectrum of fruit juice in the range of 330 nm to 800 nm.



You can find more information about the configuration of methods in the Reference Manual. **See** [Download the Reference Manual ▶ Page 17].

You can find parameter descriptions in the help embedded on the instrument. **See** [View parameter descriptions ▶ Page 27].

### Overview of the analysis

- Disposable macro cuvettes with 10 mm path length are used.
- The blank solution is only measured once at the beginning of the analysis.
- Users can enter a unique identifier for each sample.
- The results for each sample are exported as a CSV file to a USB flash drive.
- The configuration of the scan method is saved.

### Overview of the actions

- 1 [Prepare the cuvettes ▶ Page 28].
- 2 [Prepare the spectrophotometer ▶ Page 29].
- 3 [Configure the scan method ▶ Page 30].
- 4 [Perform the analysis ▶ Page 32].

### 5.4.1 Prepare the cuvettes

#### Material

- Blank solution: 3 mL deionized water
- First sample: 3 mL 1:10 dilution of clear or transparent fruit juice (e.g., grape, apple, cranberry)
- Second sample: 3 mL 1:5 dilution of fruit juice
- Three disposable macro-cuvettes with a path length of 10 mm
- Plastic pipettes
- Lint-free optical tissues
- Waste container

#### Procedure

- 1 Hold the cuvette on its frosted sides and check that the clear sides of the cuvette are clean and free of scratches.
- 2 If necessary, clean the clear sides with a lint-free tissue or replace the cuvette.
- 3 Fill a pipette with 2 mL of blank solution.

- 4 Insert the pipette tip (1) into the cuvette so that it touches the lower, inner side (2) of the cuvette.
- 5 Slowly pipette the blank solution into the cuvette.
- 6 If air is trapped in the blank solution, empty the cuvette and start again.
- 7 Place the cuvette in a rack.
- 8 Repeat the previous steps to fill two cuvettes with fruit juice dilutions.

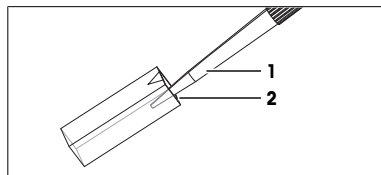

#### See also

- 🔗 Cuvettes and cuvette holders ▶ Page 10
- 🔗 Clean glass or quartz cuvettes ▶ Page 38

### 5.4.2 Prepare the spectrophotometer

#### Material

- USB flash drive

#### Set up the spectrophotometer

- Spectrophotometer is running.
- Spectrophotometer is warmed up (Easy VIS only).
- Insert a USB flash drive into the front USB socket (1).

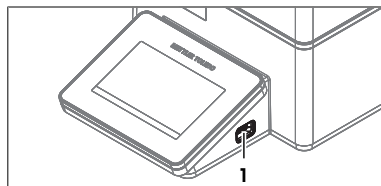

#### Configure the instrument settings

- 1 Go to (1) > .

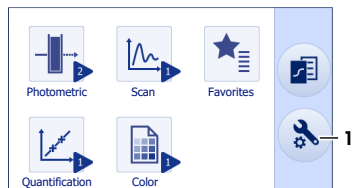

- 2 Select **Settings** (1).
- 3 Change the parameters to the settings listed in the following table.
- 4 To return to the home screen, go to (2) > .

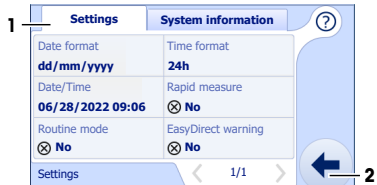

Parameter	Setting	Explanation
<b>Routine mode</b>	<b>No</b>	You can change the parameters of a method in the method editor.
<b>Rapid measure</b>	<b>No</b>	During analysis, you will be prompted to insert the samples.
<b>EasyDirect warning<sup>1)</sup></b>	<b>No</b>	There is no warning if EasyDirect is disconnected.

1) The EasyDirect software is only supported in firmware version 1.1.0 or higher.

### See also

- 🔗 Analysis compartment ▶ Page 8
- 🔗 Cuvette carousels ▶ Page 9
- 🔗 Cuvettes and cuvette holders ▶ Page 10
- 🔗 Overview of home screen and functions ▶ Page 11
- 🔗 Menu structure ▶ Page 13
- 🔗 Install the cuvette carousel ▶ Page 20
- 🔗 Change the cuvette carousel ▶ Page 21
- 🔗 Start up the spectrophotometer ▶ Page 23
- 🔗 View parameter descriptions ▶ Page 27

## 5.4.3 Configure the scan method

### Open the method editor

1 Select  (1).

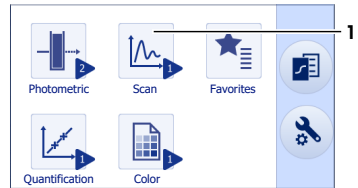

2 Select  (1).



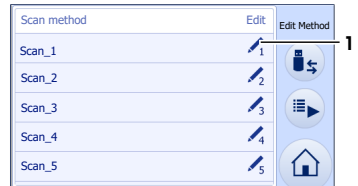

3 Select  (1).



### Configure the general parameters

1 Select **Method name** (1).



- Use **abc** (4) to cycle through keyboard layouts for capital and lower case letters, numbers, and symbols.
- Enter DEMO\_1 for the **Method name** (1).
- Enter DEMO\_1 for the **Method name** (1).
- Tap  (2) to save changes or  (3) to close without saving changes.
- Change the parameters to the settings listed in the following table.
- Use the arrows (1) to move between windows.



Parameter	Setting	Explanation
<b>Method name</b>	DEMO_1	Defines the name of the method.
<b>Printout</b>	No	No results are printed after measurement.
<b>Export to USB</b>	Short	A short format result is exported to the USB flash drive as a CSV file.
<b>Export to EasyDirect<sup>1)</sup></b>	No	Results are not exported to EasyDirect.
<b>Sample ID</b>	Variable	The spectrophotometer prompts users to enter a sample identifier before each measurement.
<b>Method barcode</b>	–	Method cannot be started with a barcode reader.
<b>Favorites Nr.</b>	None	Method cannot be started from the favorites list.

<sup>1)</sup> The EasyDirect software is only supported in firmware version 1.1.0 or higher.

### Configure the measurement parameters

- Select **Measurement** (1).
- Change the parameters to the settings listed in the following table.
- Use the arrows (2) to move between windows.



Parameter	Setting	Explanation
<b>Path length</b>	Auto	The spectrophotometer detects which cuvette holder is in the measurement position. The path length of this cuvette holder is used in calculations.
<b>Min. wavelength</b>	330.0 nm	The scanning range is 330 nm to 800 nm.
<b>Max. wavelength</b>	800.0 nm	
<b>Scan speed</b>	Medium	The full scan takes less than 1.5 minutes. A balance is maintained between accuracy and measurement duration.
<b>Step</b>	1.0 nm	The wavelength interval between two points is set to 1.0 nm.

Parameter	Setting	Explanation
<b>Results</b>	<b>A</b>	Results are reported as absorbance for each wavelength.
<b>Peaks/Valleys</b>	<b>Both</b>	Peaks and valleys in the spectrum will both be listed in the results.
<b>Sensitivity</b>	<b>Low</b>	Only the most prominent peaks and valleys are marked in the spectrum and listed in the values table.
<b>Detect <math>\lambda</math> min.</b>	330.0 nm	The detection range for peak/valley determination is 330 nm to 800 nm.
<b>Detect <math>\lambda</math> max.</b>	800.0 nm	

#### See also

- 🔗 Overview of home screen and functions ▶ Page 11
- 🔗 View parameter descriptions ▶ Page 27

### 5.4.4 Perform the analysis

#### Material

- Waste container
- Cuvette with blank solution
- Cuvette with first sample
- Cuvette with second sample

#### Measure the blank solution

- Example scan method DEMO\_1 is configured.
- A 10 mm cuvette holder is in the measurement position (1).
- The lid is closed.

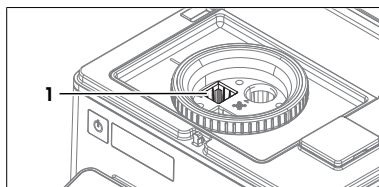

- 1 Tap  (1) to start the analysis.

- ➔ You are prompted to insert the cuvette containing blank solution.

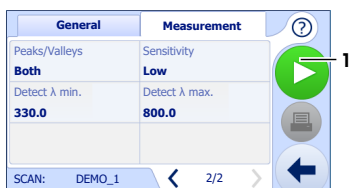

- 2 Press down on the lid (1) to open the analysis compartment.

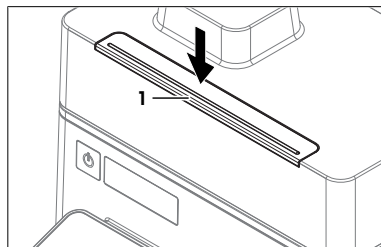

- 3 Hold the top of the cuvette containing blank solution by the frosted sides (1) and lift it out of the rack.
- 4 Check that the clear sides of the cuvette are clean.
- 5 If necessary, clean the clear sides with a lint-free tissue.

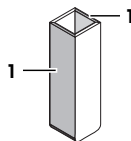

- 6 Orient the cuvette (1) so that the frosted sides are directed towards the front and back of the spectrophotometer.
- 7 To avoid scratching the cuvette's surface, insert the cuvette vertically into the cuvette holder (2).
- 8 Close the lid.
  - ➔ The measurement starts.

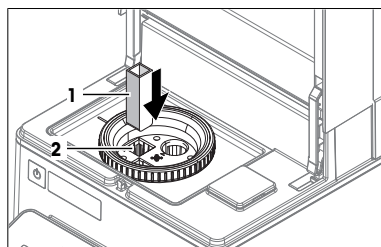

- ➔ The revolving circle (1) shows that the measurement is in progress.

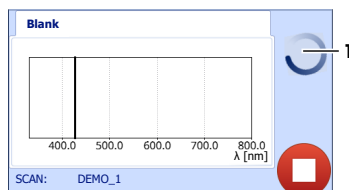

- ➔ When the measurement is complete, the revolving circle is replaced by a play button (1).
- ➔ You are prompted to insert the cuvette containing sample.



### Scan the first sample

- 1 Open the lid to remove the cuvette (1) from the measurement position (2).
- 2 Lift the cuvette out, being careful to hold it vertically.
- 3 Place the cuvette in a rack.

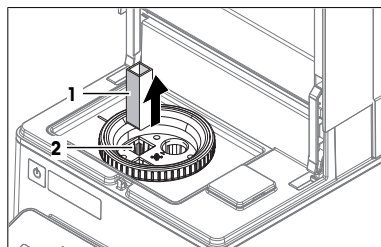

- 4 Hold the top of the cuvette containing first sample by the frosted sides (1) and lift it out of the rack.
- 5 Check that the clear sides of the cuvette are clean.
- 6 If necessary, clean the clear sides with a lint-free tissue.

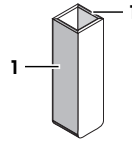

- 7 Orient the cuvette (1) so that the frosted sides are directed towards the front and back of the spectrophotometer.
- 8 To avoid scratching the cuvette's surface, insert the cuvette vertically into the cuvette holder (2).
- 9 Close the lid.
  - ➔ You are prompted to enter a sample identifier.

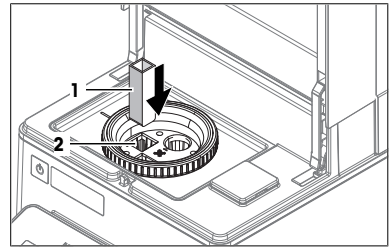

10 For **Sample ID** (1), enter an identifier.

11 Tap  (2).

- ➔ The measurement starts.

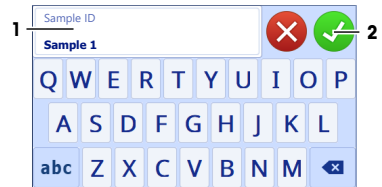

- ➔ The revolving circle (1) shows that the measurement is in progress.

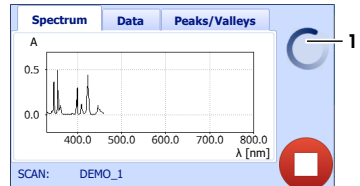

- ➔ When the measurement is complete, the revolving circle is replaced by  (1).
- ➔ Results are displayed on the touch screen.
- ➔ Results are exported to the USB flash drive as a CSV file.

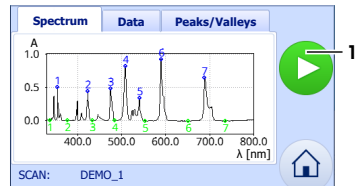

⇒ Results can be viewed on the touch screen by navigating the **Spectrum**, **Data** and **Peaks/Valleys** tabs.

Spectrum		Data	Peaks/Valleys
		$\lambda$ [nm]	Absorbance
		352.0	0.017
		353.0	0.019
		354.0	0.054
1	P	355.0	0.499
		356.0	0.270

SCAN: DEMO\_1

⇒ The analysis of the first sample is complete.

Spectrum		Data	Peaks/Valleys
		$\lambda$ [nm]	Absorbance
1	V	338.0	0.008
1	P	355.0	0.499
2	V	378.0	0.001
2	P	424.0	0.440
3	V	334.0	0.000

SCAN: DEMO\_1

### Scan the second sample

1 Tap  (1).

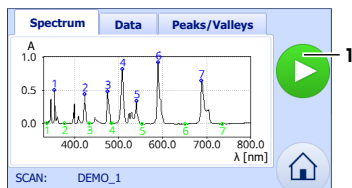

⇒ You are prompted to insert the cuvette containing sample.

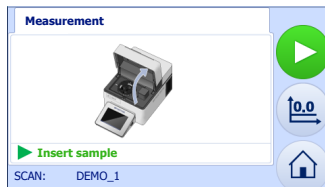

- 2 Open the lid to remove the cuvette (1) from the measurement position (2).
- 3 Lift the cuvette out, being careful to hold it vertically.
- 4 Place the cuvette in a rack.

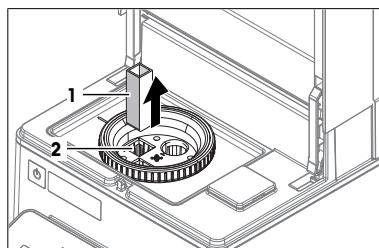

5 Hold the top of the cuvette containing second sample by the frosted sides (1) and lift it out of the rack.

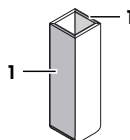

- 6 Orient the cuvette (1) so that the frosted sides are directed towards the front and back of the spectrophotometer.
- 7 To avoid scratching the cuvette's surface, insert the cuvette vertically into the cuvette holder (2).
- 8 Close the lid.
  - ➔ You are prompted to enter a sample identifier.

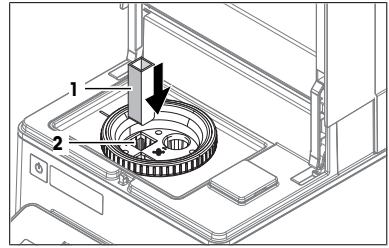

- 9 For **Sample ID** (1), enter an identifier.
- 10 Tap  (2).
  - ➔ The measurement starts.

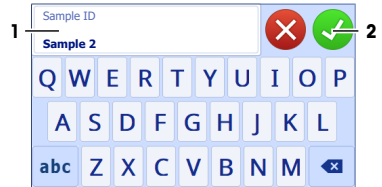

- ➔ The revolving circle (1) shows that the measurement is in progress.

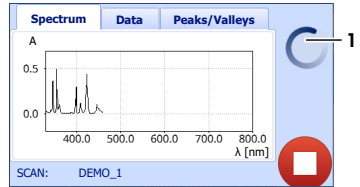

- ➔ When the measurement is complete, the revolving circle is replaced by  (1).
- ➔ Results are displayed on the touch screen.
- ➔ Results are exported to the USB flash drive as a CSV file.

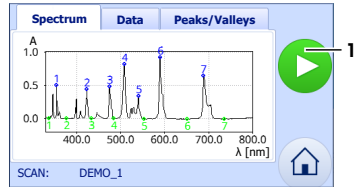

- 11 Open the lid to remove the cuvette (1) from the measurement position (2).
- 12 Close the lid.
- 13 To return to the home screen, tap .
- ➔ Spectrum determination of fruit juice is complete.

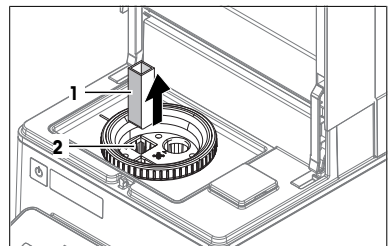

## 6 Maintenance

In this chapter you find descriptions of the maintenance tasks you should perform on your spectrophotometer. Any other maintenance tasks need to be performed by a service technician that has been qualified by METTLER TOLEDO.

If you experience problems with your spectrophotometer, contact your authorized METTLER TOLEDO service representative or dealer.

METTLER TOLEDO recommends that a preventive maintenance and calibration certification is done at least once a year through your authorized METTLER TOLEDO service representative or dealer.

► [www.mt.com/contact](http://www.mt.com/contact)

## 6.1 Maintenance schedule

### After each measurement series

Task	Link
Clean the cuvettes	<b>See</b> [Clean glass or quartz cuvettes ► Page 38]

### Every day

Task	Link
Clean the cuvettes	<b>See</b> [Clean glass or quartz cuvettes ► Page 38]

### Every month

Task	Link
Clean the housing	<b>See</b> [Clean the housing ► Page 38]
Clean the analysis compartment	<b>See</b> [Clean the analysis compartment ► Page 39]
Clean the storage compartment	<b>See</b> [Clean the storage compartment ► Page 39]

### Every three months

Task	Link
Perform system baseline adjustment (Easy VIS only)	<b>See</b> [Perform adjustments ► Page 41]

### Every six month

Task	Link
Perform system baseline adjustment (Easy UV only)	<b>See</b> [Perform adjustments ► Page 41]

### Before periods of inactivity

Task	Link
Clean the cuvettes	<b>See</b> [Clean glass or quartz cuvettes ► Page 38]
Clean cuvette carousels	<b>See</b> [Clean the cuvette carousels ► Page 38]
Clean the housing	<b>See</b> [Clean the housing ► Page 38]
Clean the analysis compartment	<b>See</b> [Clean the analysis compartment ► Page 39]
Clean the storage compartment	<b>See</b> [Clean the storage compartment ► Page 39]

## 6.2 Clean the spectrophotometer



### NOTICE

#### Damage to the spectrophotometer due to inappropriate cleaning methods

Inappropriate cleaning agents can damage the housing or other parts of the spectrophotometer. If liquids enter the housing, they can damage the spectrophotometer.

- 1 Make sure the cleaning agent is compatible with the material of the part you want to clean.
- 2 Make sure that no liquid enters the interior of the spectrophotometer.

If you have questions about the compatibility of cleaning agents, contact your authorized METTLER TOLEDO service representative or dealer.

► [www.mt.com/contact](http://www.mt.com/contact)

### See also

🔗 Technical data ▶ Page 48

## 6.2.1 Clean glass or quartz cuvettes

METTLER TOLEDO recommends the following cleaning agents:

- Water
- Deionized water
- Spectroscopy grade isopropanol
- Spectroscopy grade acetone

Some of the recommended cleaning agents are hazardous materials. Wear protective gear as required by the safety-data sheets of the cleaning agents you use and the safety rules of your workplace.

### Clean the inside of the cuvette

- 1 Hold the top of the cuvette by the frosted sides.
- 2 Rinse the cuvette under warm, running water.
- 3 Rinse the inside of the cuvette with deionized water.
- 4 Rinse the inside of the cuvette with acetone.
- 5 If the cuvette is still dirty, clean it with an appropriate optical cell cleaning solution. Take care to follow the instructions of the supplier.

### Clean the outside of the cuvette

- 1 Hold the top of the cuvette by the frosted sides.
- 2 Wipe the outside of the cuvette with a lint-free optical tissue moistened with spectroscopy grade isopropanol.
- 3 To dry the outside of the cuvette, wipe it with a dry, lint-free optical tissue.
- 4 Make sure that the clear sides are free of lint.
- 5 Store the cuvette in its original packaging or in an appropriate cuvette holder.

## 6.2.2 Clean the housing

METTLER TOLEDO recommends the following cleaning agents:

- Water
- Water with a mild detergent

### Procedure

- The spectrophotometer is shut down.
- 1 Wipe the housing with a cloth moistened with the cleaning agent.
  - 2 Wipe the housing with a cloth moistened with water.

### See also

🔗 Technical data ▶ Page 48

## 6.2.3 Clean the cuvette carousels

METTLER TOLEDO recommends the following cleaning agents:

- Water
- Water with a mild detergent

### Procedure

- 1 Remove the cuvette carousel.
- 2 Rinse the cuvette carousel with the cleaning agent.
- 3 Air-dry the cuvette carousel or dry it with a soft tissue.
- 4 Install the cuvette carousel.

### See also

- 🔗 Install the cuvette carousel ▶ Page 20
- 🔗 Change the cuvette carousel ▶ Page 21
- 🔗 Technical data ▶ Page 48

## 6.2.4 Clean the analysis compartment

METTLER TOLEDO recommends the following cleaning agents:

- Water
- Water with a mild detergent

### Procedure

- The spectrophotometer is shut down.
- 1 Press down on the lid to open the analysis compartment.
  - 2 Remove the cuvette carousel.
  - 3 Wipe the surface of the analysis compartment with a cloth moistened with the cleaning agent.
  - 4 Press the release latch (2) on the inside of the drip tray.
  - 5 Slightly move the drip tray (1) back and forth while lifting it out.
  - 6 Wipe the drip tray with a cloth moistened with the cleaning agent.
  - 7 Air-dry the drip tray or dry it with a soft tissue.

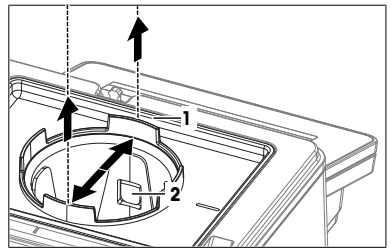

- 8 Align the guide (1) with the guide notch (2) and insert the drip tray into the measurement chamber.
- 9 Push the drip tray down until it clicks into place.
- 10 Install the cuvette carousel.

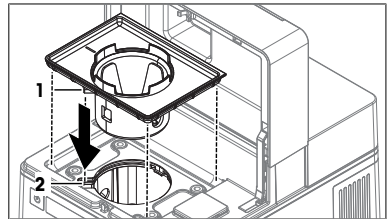

### See also

- 🔗 Analysis compartment ▶ Page 8
- 🔗 Install the cuvette carousel ▶ Page 20
- 🔗 Change the cuvette carousel ▶ Page 21
- 🔗 Technical data ▶ Page 48

## 6.2.5 Clean the storage compartment

METTLER TOLEDO recommends the following cleaning agents:

- Water
- Water with a mild detergent

## Procedure

- The spectrophotometer is shut down.
- 1 Lift the back cover (1) of the storage compartment.
  - 2 Wipe the back cover with a cloth moistened with the cleaning agent.
  - 3 Lift the cuvette carousels out of the cuvette carousel bay.
  - 4 Lift the Allen wrench out of the allen wrench tray.
  - 5 Wipe the surface of the storage compartment with a cloth moistened with the cleaning agent.
  - 6 Reinstall cuvette carousels and Allen wrench.

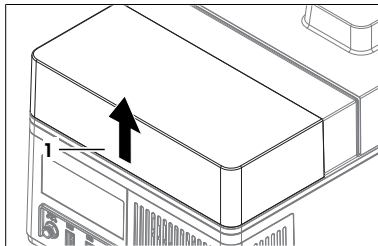

## See also

- 🔗 Change the cuvette carousel ▶ Page 21
- 🔗 Technical data ▶ Page 48

## 6.2.6 Clean up spills

METTLER TOLEDO recommends the following cleaning agents:

- Water
- Water with a mild detergent

### Clean the inside

- 1 Shut down the spectrophotometer.
- 2 Pull the plug of the power cable out of the power outlet.
- 3 Remove all cuvettes.
- 4 Remove and clean the cuvette carousel.
- 5 Wipe the surface of the analysis compartment with a cloth moistened with the cleaning agent.
- 6 Remove and clean the drip tray.
- 7 Without touching the lenses (2), wipe the measurement chamber (1) with a soft dry cloth.
- 8 Install the drip tray and the cuvette carousel.
- 9 Close the lid.

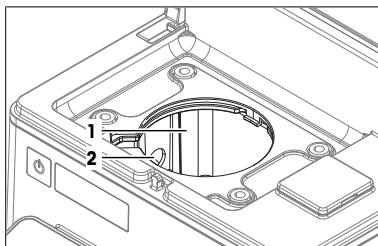

### Clean the outside

- 1 Tilt the spectrophotometer and carefully lower it onto its right side.

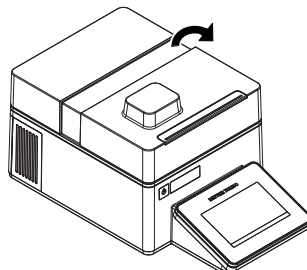

- 2 Wipe the drain hole (1) and the bottom of the spectrophotometer with a cloth moistened with the cleaning agent.
- 3 Wipe the work surface with a cloth moistened with the cleaning agent.
- 4 Return the spectrophotometer to its upright position.
- 5 Connect the spectrophotometer to the power supply.

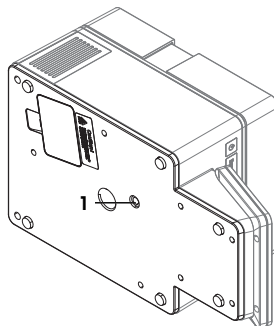

#### See also

- 🔗 Connect and disconnect the power supply ▶ Page 18
- 🔗 Install the cuvette carousel ▶ Page 20
- 🔗 Change the cuvette carousel ▶ Page 21
- 🔗 Clean the cuvette carousels ▶ Page 38
- 🔗 Clean the analysis compartment ▶ Page 39
- 🔗 Technical data ▶ Page 48

### 6.3 Perform adjustments

Adjustments are performed to ensure measurement accuracy. If adjustments are not performed when required, measurement results may be unreliable.

Once an adjustment has been started, there is no way to stop the procedure. Do not turn off or unplug the spectrophotometer during an adjustment. Do not restart the spectrophotometer until a successful adjustment has been completed. Do not open the lid or interfere with an adjustment that is in progress. Any interruption to an adjustment in progress may result in unreliable measurement results. If an adjustment is interrupted, it needs to be rerun until successful completion.

There are two methods of adjustment:

- System baseline
- Dark current

Adjustments are required during first-time startup.

Adjustments are required for maintenance as described below:

#### System baseline

After the spectrophotometer has warmed up for at least one hour, system baseline adjustment takes approximately five minutes.

- After instrument firmware update
- After optical firmware update
- After lamp replacement (Easy VIS only)
- Every 3 months (Easy VIS only)
- Every 6 months (Easy UV only)

#### Dark current (Easy VIS only)

After the spectrophotometer has warmed up for at least one hour, dark current adjustment takes approximately 20 minutes.

- After instrument firmware update
- After optical firmware update

- After the operational environment has changed (e.g., the spectrophotometer is moved to a different location)

### Procedure

- Spectrophotometer has been warmed up for at least one hour. For example, after lamp sleep or start up.
- There is nothing blocking the light path. For example, no cuvette in measurement position.
- The lid is closed.

1 Go to (1) > .

2 Select either **System baseline** or **Dark current**.

3 Tap .

- The selected adjustment is performed.

➔ A window opens confirming successful adjustment.

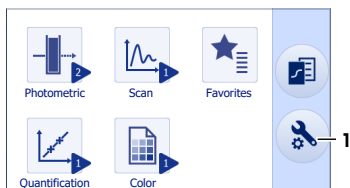

### See also

- Analysis compartment ▶ Page 8
- Overview of home screen and functions ▶ Page 11
- Overview of the measurement technology ▶ Page 14
- Start up the spectrophotometer ▶ Page 23
- Replace the lamp (Easy VIS only) ▶ Page 42

## 6.4 Replace parts



Read the Reference Manual for a list of accessories and order information. See [Download the Reference Manual ▶ Page 17].

### See also

- Download the Reference Manual ▶ Page 17

### 6.4.1 Replace the lamp (Easy VIS only)

The lamp lifetime varies and depends on factors such as the switching frequency. The lamp needs to be replaced after a burn time of about 2000 h. The spectrophotometer monitors the light emitted by the lamp. When changes in the light intensity indicate that the lamp is near the end of its life, users are notified to prepare its replacement.

When you replace the lamp, you need to perform adjustments and reset the lamp usage.

- Perform adjustments: System baseline adjustment and dark current adjustment
- Reset lamp usage: This is important because blank values that have been measured with the old lamp are no longer valid. When you reset the lamp usage time, the blank values are deleted and users are prompted to measure them again.

### See also

- Perform adjustments ▶ Page 41
- Reset the lamp usage time (Easy VIS only) ▶ Page 44

#### 6.4.1.1 Remove the lamp (Easy VIS only)

### Material

- Allen wrench

### Procedure

1 Shut down the spectrophotometer.

- 2 Pull the plug of the power cable out of the power outlet.
- 3 Remove all cuvettes.
- 4 Tilt the spectrophotometer and carefully lower it onto its right side.

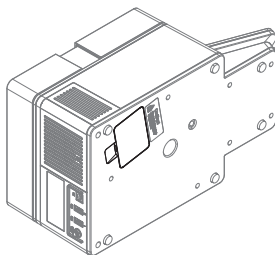

- 5 **⚠ CAUTION: Burns due to hot surfaces. The light bulb heats up the surfaces of the lamp and battery compartment. Let the spectrophotometer cool down for 15 minutes.**

- 6 Pull the latch (1) and remove the cover (2).

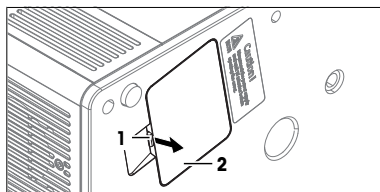

- 7 Press down the latch (4) and pull the lamp plug out of the lamp socket (3).

- 8 Turn the two screws (5) anticlockwise with the Allen wrench.

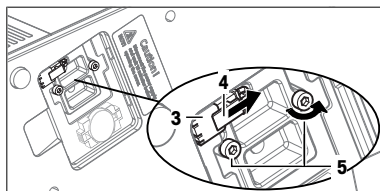

- 9 Grab the grip (1) and carefully pull out the lamp.

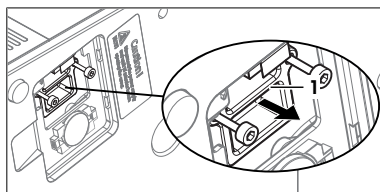

#### See also

- 🔗 Top and bottom view ▶ Page 6
- 🔗 Connect and disconnect the power supply ▶ Page 18

#### 6.4.1.2 Reinstall the lamp (Easy VIS only)



#### NOTICE

##### Damage to the light bulb due to oily residue

If you touch the light bulb with your bare hand, your skin leaves oily residue on the light bulb.

- Do not touch the light bulb.

#### Material

- Allen wrench
- New lamp

## Procedure

- 1 Hold the new lamp by the grip (1) and carefully insert it as shown.
- 2 Use the Allen wrench to tighten the two screws (3) clockwise.
- 3 Insert the lamp plug (2) into the lamp socket (1).
- 4 Install the cover (4).
- 5 Return the spectrophotometer to its upright position.
- 6 Connect the spectrophotometer to the power supply.

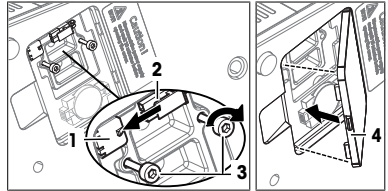
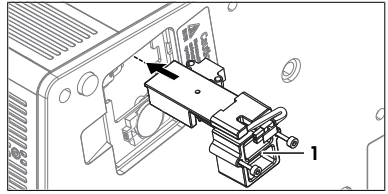

## See also

- 🔗 Top and bottom view ▶ Page 6
- 🔗 Connect and disconnect the power supply ▶ Page 18

### 6.4.1.3 Reset the lamp usage time (Easy VIS only)

- 1 Go to (1) > .
- 2 Select **Settings** (1).
- 3 Tap the arrow (3) to switch to the next page.
- 4 Tap **Lamp reset** (2).
- 5 Perform adjustments.

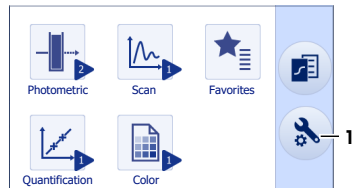

## See also

- 🔗 Perform adjustments ▶ Page 41

### 6.4.2 Replace the battery

#### Material

- Battery: CR2032

#### Remove the battery

- 1 Shut down the spectrophotometer.
- 2 Pull the plug of the power cable out of the power outlet.
- 3 Remove all cuvettes.

- 4 Tilt the spectrophotometer and carefully lower it onto its right side.

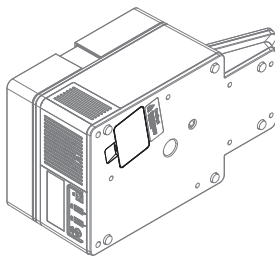

- 5 **⚠ CAUTION: Burns due to hot surfaces. The light bulb heats up the surfaces of the lamp and battery compartment. Let the spectrophotometer cool down for 15 minutes.**

- 6 Pull the latch (1) and remove the cover (2).
- 7 Pull the battery (4) out of the battery holder (3).
- 8 Dispose of the battery according to local laws and regulations.

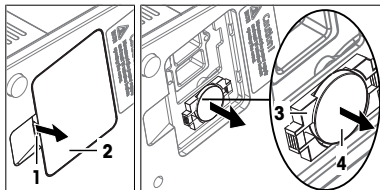

### Install the battery

- 1 Push a new battery (1), with the plus side facing you, into the battery holder (2) until it snaps into place.
- 2 Install the cover (3).
- 3 Return the spectrophotometer to its upright position.
- 4 Connect the spectrophotometer to the power supply.

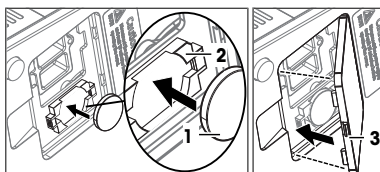

### See also

- 🔗 Top and bottom view ▶ Page 6
- 🔗 Connect and disconnect the power supply ▶ Page 18
- 🔗 Technical data ▶ Page 48

## 6.5 Prepare the spectrophotometer for storage

### Procedure

- 1 Shut down the spectrophotometer.
- 2 Remove all cuvettes.
- 3 Install one cuvette carousel in the analysis compartment and the other two carousels in the storage compartment.
- 4 Close the lid, the back cover and the cover of the front USB-A socket.
- 5 Disconnect the spectrophotometer from the power supply.
- 6 Disconnect any external accessories from the spectrophotometer. If an internal barcode reader is installed, do not remove it.
- 7 Clean the spectrophotometer.
- 8 Protect the spectrophotometer from dust.
- 9 Store the spectrophotometer in a dry and clean place.

### See also

- 🔗 Connect and disconnect the power supply ▶ Page 18
- 🔗 Clean the spectrophotometer ▶ Page 37
- 🔗 Technical data ▶ Page 48

## 6.6 Transport the spectrophotometer

If you have questions about transporting your spectrophotometer, contact your authorized METTLER TOLEDO service representative or dealer.

► [www.mt.com/contact](http://www.mt.com/contact)

### Procedure

- 1 Shut down the spectrophotometer.
- 2 Remove all cuvettes.
- 3 Install one cuvette carousel in the analysis compartment and the other two carousels in the storage compartment.
- 4 Close the lid, the back cover and the cover of the front USB-A socket.
- 5 Disconnect the spectrophotometer from the power supply.
- 6 Disconnect any external accessories from the spectrophotometer. If an internal barcode reader is installed, do not remove it.
- 7 Clean the spectrophotometer.
- 8 Secure the Allen wrench in the storage compartment with adhesive tape.
- 9 Keep the spectrophotometer upright while you transport it.
- 10 If you transport the spectrophotometer over long distances, use the original packaging.

### See also

- 🔗 Connect and disconnect the power supply ► Page 18
- 🔗 Clean the spectrophotometer ► Page 37
- 🔗 Technical data ► Page 48

## 6.7 Dispose of the spectrophotometer

### Dispose of the battery

- 1 Remove the battery.
- 2 Dispose of the battery according to local laws and regulations.

### Dispose of the spectrophotometer

In conformance with the European Directive 2012/19/EU on Waste Electrical and Electronic Equipment (WEEE) this device may not be disposed of in domestic waste. This also applies to countries outside the EU, per their specific requirements.



Please dispose of this product in accordance with local regulations at the collecting point specified for electrical and electronic equipment. If you have any questions, please contact the responsible authority or the distributor from which you purchased this device. Should this device be passed on to other parties, the content of this regulation must also be related.

### See also

- 🔗 Replace the battery ► Page 44
- 🔗 Technical data ► Page 48

## 7 Troubleshooting

### 7.1 Handle error messages

- 1 Write down the error code (1) and the measures described (2).
- 2 Follow the instructions (2).
- 3 If the error occurs again, prepare the required information. See [Request support ▶ Page 47].
- 4 Contact your authorized METTLER TOLEDO service representative or dealer.



▶ [www.mt.com/contact](http://www.mt.com/contact)

### 7.2 Request support

Collect the following information before you contact your authorized METTLER TOLEDO service representative or dealer for technical support.

- Instrument model type (e.g., Easy VIS)
- Instrument serial number
- Error code
- A description of the actions that lead to the error or the issues that you cannot resolve.
- An export of the system information.

#### Export system information and instrument status

- 1 Insert a USB flash drive into the front USB socket (1).

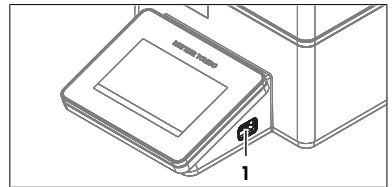

- 2 Go to  (1) > .

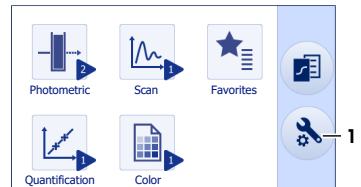

- 3 Select **System information** (1).
  - 4 Tap the arrow (2) to switch to the next page.
  - 5 Tap **Export** (3).
- ➔ A message opens when the export is completed.



#### See also

-  View the firmware version and other system information ▶ Page 48

## 7.3 View the firmware version and other system information

Firmware versions and other system information can be accessed in the system settings. Parameters that can be viewed include:

- Lamp usage
- Instrument serial number
- Instrument firmware version
- Spectroquant® version (only when SQKitReader internal barcode reader is installed)
- Optical unit serial number
- Optical unit firmware version
- Operating system version
- Licensing information
- System information export

### Procedure

1 Go to (1) > .

2 Select **System information** (1).

3 To view parameter descriptions, tap (2).

4 Tap the parameter that interests you.

5 To move between windows, use the arrows (3).

6 To return to the home screen, go to (4) > .

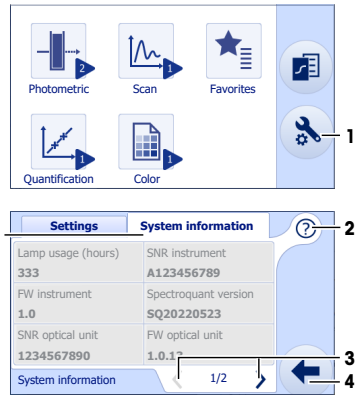

## 8 Technical data



Read the Reference Manual for additional technical data. See [Download the Reference Manual ▶ Page 17].

### 8.1 Spectrophotometer

#### Power supply

Characteristic		Easy UV	Easy VIS
<b>Spectrophotometer</b>	Input rating	24 V DC, 2.5 A	24 V DC, 2.5 A
	Power consumption	35 W	40 W
	Socket	DC-Jack, 2.5 mm	DC-Jack, 2.5 mm
<b>AC/DC adapter</b>	Input rating	100...240 V AC ±10 %, 1.5 A	100...240 V AC ±10 %, 1.5 A
	Input frequency	50/60 Hz	50/60 Hz
	Output rating	24 V DC, 2.5 A	24 V DC, 2.5 A

## Instrument

Characteristic		Value
<b>Dimensions</b>	Width	201 mm
	Depth	362 mm
	Height	176 mm
<b>Weight</b>		4.25 kg
<b>Display</b>	Technology	Color display with capacitive touch screen
	Size	4.3 "
	Resolution	480 x 272 pixel
<b>Materials</b>	Cuvette carousel	PA66 (polyamide)
	Touch screen	Alkali-aluminosilicate glass
	Housing	PP (polypropylene)
	Analysis compartment	PP (polypropylene)
	Drip tray	PP (polypropylene)
	Measurement chamber	PP (polypropylene)
	Storage compartment	PP (polypropylene)
<b>Battery</b>	Type	CR2032

## Site requirements

Characteristic		Value
<b>Ambient conditions</b>	Ambient temperature	5...40 °C
	Recommended ambient temperature for operation	20...25 °C
	Relative humidity	Non-condensing, max. 80 % for temperatures up to 31 °C, decreasing linearly to 50 % at 40 °C
	Altitude	≤5000 m above sea level
	Use	Indoor
	Overvoltage category	II
	Pollution degree	2
<b>Storage conditions</b>	Temperature	-20...+70 °C
	Relative humidity	10...90 %

## Connections

Characteristic		Value
<b>PC</b>	Socket	Device, USB B 2.0, full speed
	Cable length	Max. 3 m
<b>USB 1/USB 2/ front USB socket</b>	Socket	Host, USB A 2.0 , full speed
	Output current	Max. 500 mA
	Cable length	Max. 3 m
Internal barcode reader socket	Socket	Spring-loaded pin
	Voltage	3.3 V DC
	Current	0.17 A

## 8.2 Measurements

Characteristic		Easy UV	Easy VIS
<b>Optical configuration</b>		Dual beam	Dual beam
<b>Light source</b>		Flashing Xenon lamp	Tungsten lamp
<b>Detector</b>		Dual silicon photo-diodes	Dual silicon photo-diodes
<b>Scanning speed</b>		max. 2000 nm/min	max. 2800 nm/min
<b>Spectral bandwidth</b>		3 nm	4 nm
<b>Wavelength</b>	Range	190...1000 nm	330...1000 nm
	Accuracy	±1.5 nm	±1.5 nm
	Repeatability	≤0.5 nm	≤0.5 nm
<b>Photometric</b>	Display range	-3.0 ... +5.0 A	-3.0 ... +5.0 A
	Accuracy at 0.5 A	±0.002 A	±0.002 A
	Accuracy at 1.0 A	±0.005 A	±0.005 A
	Accuracy at 2.0 A	±0.005 A	±0.005 A
	Accuracy at 2.5 A	±0.010 A	±0.010 A
	Repeatability at 1 A	≤0.001 A	≤0.001 A
<b>Stray light</b>	at 340 nm	≤0.1 %T	≤0.1 %T
	at 220 nm	≤0.5 %T	–
	at 198 nm	≤2.5 %T	–
<b>Noise</b>	at 0 A	≤0.001 A	≤0.001 A
	at 1 A	≤0.002 A	≤0.002 A
	at 2 A	≤0.004 A	≤0.004 A
<b>Drift</b>	at 260 nm	≤0.002 A/h	–
	at 500 nm	–	≤0.002 A/h
<b>Baseline flatness</b>		±0.003 A	±0.003 A







## To protect your product's future:

METTLER TOLEDO Service assures the quality, measuring accuracy and preservation of value of this product for years to come.

Please request full details about our attractive terms of service.

► [www.mt.com/service](http://www.mt.com/service)

[www.mt.com/easyplus-uvvis](http://www.mt.com/easyplus-uvvis)

For more information

**Mettler-Toledo GmbH**

Im Langacher 44  
8606 Greifensee, Switzerland  
[www.mt.com/contacts](http://www.mt.com/contacts)

Subject to technical changes.  
© 10/2022 METTLER TOLEDO. All rights reserved.  
30705172B



30705172