

# Cole-Parmer®

## SP-500-NANO

### Spectrophotometer



Instruction Manual  
JEN0003-CPB Version 1.2

**Cole-Parmer®**

# Contents

<b>Section 1 - Introduction .....</b>	<b>7</b>
1.1 General Description .....	7
1.2 Important Safety Advice .....	7
1.3 Symbols Defined .....	7
1.4 Electrical Requirements .....	8
<b>Section 2 - Installation .....</b>	<b>9</b>
2.1 Unpacking .....	9
2.2 Installation Conditions .....	9
2.3 Overview .....	10
2.3.1 Main View .....	10
2.3.2 Rear View .....	10
<b>Section 3 - Theory and Practice of Spectroscopy Measurement.....</b>	<b>11</b>
3.1 Theory of Spectroscopy Measurement .....	11
3.2 Spectroscopy Measurement .....	12
3.3 Good Practice Guidelines .....	13
<b>Section 4 - Instrument Set up.....</b>	<b>14</b>
4.1 Start up Screen .....	14
4.2 Navigation .....	14
4.3 Methods .....	15
4.4 Results .....	16
4.5 Settings .....	16
4.5.1 Instrument Status .....	16
4.5.2 Measurement Settings .....	16
4.5.3 Network Connections .....	17
4.5.4 Storage .....	17
4.5.5 Regional Settings .....	18
4.5.5.1 Setting the Time .....	18
4.5.5.2 Setting the Date .....	19
4.5.5.3 Setting the Time Zone .....	19
4.5.5.4 Instrument Language .....	20
4.5.6 Service Settings .....	20
<b>Section 5 - Micro Volume Settings.....</b>	<b>21</b>
<b>Section 6 - Adding, Removing and Recovering Samples .....</b>	<b>22</b>
6.1 Adding a Sample .....	22
6.2 Removing a Sample .....	22
6.3 Recovering a Sample .....	22

<b>Section 7 - Photometrics</b>	<b>23</b>
7.1 Method Set up	23
7.1.1 Selecting a Wavelength	23
7.2 Blank Measurement	24
7.3 Sample Measurement	24
<b>Section 8 - Concentration</b>	<b>25</b>
8.1 Method Set up	25
8.1.1 Selecting a Wavelength	25
8.1.2 Using a Factor	25
8.1.3 Using a Standard	26
8.1.4 Selecting Concentration Units	26
8.2 Blank Measurement	26
8.2.1 Calibrating to a Factor	27
8.2.2 Calibrating to a Standard	27
8.3 Sample Measurement	28
8.3.1 Measuring a Sample After Calibrating to a Factor	28
8.3.2 Measuring a Sample After Calibrating to a Standard	28
<b>Section 9 - Spectrum</b>	<b>29</b>
9.1 Method Set up	29
9.1.1 Setting Start and End Wavelengths	29
9.1.2 Setting the Scan Interval	30
9.1.3 Selecting Absorbance or % Transmittance	30
9.2 Blank Measurement	30
9.3 Sample Measurement	30
9.4 Data Analysis	31
9.4.1 Peaks and Valleys	31
9.4.2 Area Under Curve	32
9.4.2.1 Area Under Curve - Baseline Mode	32
9.4.2.2 Area Under Curve - Tangent Mode	33
<b>Section 10 - Quantitation</b>	<b>34</b>
10.1 Method Set up	34
10.1.1 Selecting a Wavelength	34
10.1.2 Selecting Number of Replicates	35
10.1.3 Selecting Concentration Units	35
10.2 Measuring Calibration Standards	36
10.3 Standard Curve	37
10.4 Sample Measurement	38

<b>Section 11 - Kinetics</b> .....	<b>39</b>
11.1    Method Set up .....	39
11.1.1    Selecting a Wavelength.....	39
11.1.2    Setting the Kinetics Measurement Time.....	40
11.1.3    Setting the Measurement Time Interval .....	40
11.1.4    Setting Lag Time .....	40
11.1.5    Selecting Absorbance or % Transmittance.....	40
11.1.6    End Point Concentration .....	40
11.2    Blank Measurement.....	41
11.3    Sample Measurement.....	41
11.4    Data Analysis.....	43
<b>Section 12 - Multi-Wavelength</b> .....	<b>44</b>
12.1    Method Set up .....	44
12.1.1    Selecting a Wavelength.....	44
12.1.2    Equation Parameters .....	45
12.1.2.1    Entering a Factor .....	46
12.1.2.2    Selecting Concentration Units.....	46
12.1.3    Selecting Absorbance or % Transmittance.....	46
12.2    Blank Measurement.....	47
12.3    Sample Measurement.....	47
<b>Section 13 - Nucleic Acid Modes</b> .....	<b>48</b>
13.1    dsDNA .....	48
13.2    ssDNA .....	48
13.3    RNA .....	48
13.4    Method Set up .....	49
13.4.1    Selecting a Wavelength.....	49
13.4.2    Equation Parameters .....	49
13.4.2.1    Entering a Dilution Volume and Sample Volume.....	50
13.4.2.2    Entering a Factor .....	50
13.5    Blank Measurement.....	51
13.6    Sample Measurement.....	51
<b>Section 14 - Protein Modes</b> .....	<b>52</b>
14.1    Direct UV.....	52
14.2    Warburg-Christian.....	52
14.3    Method Set up .....	53
14.3.1    Selecting a Wavelength.....	53
14.3.2    Equation Parameters .....	53
14.3.2.1    Entering a Dilution Volume and Sample Volume.....	53

14.3.2.2	Entering a Factor .....	53
14.4	Blank Measurement.....	54
14.5	Sample Measurement.....	54
<b>Section 15 - Colorimetric Protein Assays.....</b>		<b>55</b>
15.1	BCA .....	55
15.2	Biuret .....	55
15.3	Bradford.....	55
15.4	Lowry.....	55
15.5	Pierce 660 .....	55
15.6	Method Set up .....	56
15.6.1	Selecting a Wavelength.....	56
15.6.2	Selecting Number of Replicates .....	56
15.6.3	Selecting Concentration Units .....	57
15.7	Measuring Calibration Standards.....	57
Before the 1st standard can be measured you will need to perform a blank measurement. Open the.....		
15.8	Standard Curve .....	59
15.9	Sample Measurement.....	60
<b>Section 16 - Saving, Loading, Deleting and Printing.....</b>		<b>61</b>
16.1	Saving Methods .....	61
16.1.1	Saving Methods to Internal Memory .....	61
16.1.2	Saving Methods to USB Memory Stick.....	61
16.2	Loading Methods .....	61
16.2.1	Loading Methods from Internal Memory .....	61
16.2.2	Loading Methods from USB Memory Stick .....	61
16.3	Deleting Methods.....	61
16.4	Saving Results .....	62
16.4.1	Saving Results to Internal Memory .....	62
16.4.2	Saving Results to USB Memory Stick.....	62
16.5	Loading Results .....	62
16.5.1	Loading Results from Internal Memory .....	62
16.5.2	Loading Results from USB Memory Stick .....	62
16.6	Deleting Results.....	62
16.7	Printing .....	62
<b>Section 17 - Accessories and Spare Parts .....</b>		<b>63</b>
17.1	Optional Accessories .....	63
17.2	Spare Parts .....	63
<b>Section 18 - Maintenance and Servicing .....</b>		<b>63</b>

18.1	Routine Maintenance .....	63
18.1.1	Cleaning .....	63
18.1.2	Read Head Cleaning .....	63
18.1.3	Read Head Re-conditioning .....	64
18.1.4	In Case of Accidental Spillage.....	64
18.1.5	In Case of Contamination .....	64
18.2	Service, Repairs and Support .....	65
18.2.1	Xenon Lamp Module Replacement.....	65
18.3	Warranty .....	65
<b>Section 19 - Environmental Protection .....</b>		<b>65</b>
19.1	Packaging Material.....	65
19.2	Waste Electrical and Electronic Equipment Directive (WEEE) .....	65
<b>Section 20 - Calibration .....</b>		<b>66</b>
20.1	Calibration Solutions .....	66
20.2	Calibration Procedure.....	66
20.2.1	Step 1 - Air .....	67
20.2.2	Step 2 - Blank .....	67
20.2.3	Step 3 - Standard 1 .....	68
20.2.4	Step 4 - Standard 2 .....	68
20.2.5	Step 5 - Verification: Air .....	68
20.2.6	Step 6 - Verification: Blank .....	69
20.2.7	Step 7 - Verification: Standard.....	69
<b>Section 21 - Technical Specification .....</b>		<b>70</b>
21.1	General Specification.....	70
21.2	Weights and Dimensions .....	71
<b>Section 22 - Troubleshooting .....</b>		<b>72</b>
<b>Section 23 - Glossary of Icons .....</b>		<b>74</b>
<b>Section 24 - Chemical Compatability .....</b>		<b>75</b>
<b>Index .....</b>		<b>76</b>
<b>Declaration of Conformity .....</b>		<b>79</b>

## Section 1 - Introduction

Thank you for purchasing this Cole-Parmer product. To get the best performance from the equipment, and for your own safety, please read these instructions carefully before use.

If the equipment is not used in the manner described in this manual and with accessories other than those recommended by the manufacturer, the protection provided may be impaired.

### 1.1 General Description

The SP-500-NANO is a UV/visible spectrophotometer dedicated to life science analysis. This spectrophotometer incorporates a micro volume sample measurement accessory that allows sample volumes as low as 0.5µl to be analysed. In addition to the standard measurement modes: Photometrics, Concentration, Spectrum, Multi-wavelength, Quantitation and Kinetics, the SP-500-NANO spectrophotometer is pre-programmed with methods to determine Nucleic acid concentration and purity ratios using wavelengths recorded at 260 and 280nm, with an optional correction at 320nm. In addition there are five pre-programmed methods for protein analysis including the Bradford, Lowry, Biuret, BCA and Pierce 660 as well as Direct UV and Warburg-Christian methods.

**Note:** CPLive is no longer supported on this model.

### 1.2 Important Safety Advice

Users should be aware of the following safety advice:

- ❖ **SHOCK HAZARDS OR UNSAFE PRACTICES ARE DANGEROUS** as they can cause severe personal injury, fire or death.
- ❖ **DO NOT** use combustible substances near hot objects.
- ❖ **DO NOT** use the equipment in hazardous atmospheres.
- ❖ **DO NOT** operate or handle any part of the equipment with wet hands or use on surfaces that may become flooded.
- ❖ **NEVER** move the equipment while still connected to the power supply.
- ❖ **HIGH TEMPERATURES ARE DANGEROUS** as they can cause serious burns to operators and ignite combustible material.
- ❖ **USE CARE AND WEAR PROTECTIVE GLOVES TO PROTECT HANDS.**
- ❖ **NEVER** lift or carry the equipment during operation.
- ❖ **DO NOT** position the equipment so that it is difficult to disconnect from the mains supply using the mains plug.
- ❖ The mains outlet socket used should be located close to the equipment and readily identifiable and accessible to users.
- ❖ **DO NOT** leave equipment switched on and it is not recommended to leave any heating apparatus unattended during operation.
- ❖ The equipment should be carried using both hands.

### 1.3 Symbols Defined



## 1.4 Electrical Requirements



**THIS INSTRUMENT MUST BE GROUNDED**

**Before connection please ensure that the line supply corresponds to the power requirements below:**

<b>Power</b>	<b>Supply requirements</b>
65 W	100 V - 230 V ~ 50/60 Hz

The equipment is provided with a power supply unit and three power cables consisting of a UK 3-pin and a "Schuko" 2-pin plug for 230 V installations and a NEMA 5-15 plug for 120 V installations.

Choose the power cable appropriate for your electrical installation and discard the others. Should one of the power cables not be suitable for connecting to the power supply, replace the plug with a suitable alternative.

**THIS OPERATION SHOULD ONLY BE UNDERTAKEN BY A QUALIFIED ELECTRICIAN.**

**NOTE:** Refer to the equipment rating plate to ensure that the plug and fusing are suitable for the voltage and wattage stated. The wires in the mains cable are as follows:

<b>230 V a.c.</b>	<b>120 V a.c.</b>
HOT/LIVE - BROWN	BLACK - HOT/LIVE
NEUTRAL - BLUE	WHITE - NEUTRAL
EARTH - GREEN/YELLOW	GREEN - EARTH

The appropriate power cable and power adaptor combination should be connected to the equipment BEFORE connection to the mains supply. Should the mains lead require replacement, a cable of 1.25mm<sup>2</sup> (AWG16) of harmonised code H05VV-F connected to an IEC320 plug should be used.



**IF IN DOUBT CONSULT A QUALIFIED ELECTRICIAN**

## Section 2 - Installation

### 2.1 Unpacking

Before discarding the packaging check that all parts are present and correct.

- ① SP-500-NANO
- ② Instruction manual
- ③ UK power lead
- ④ EU power lead
- ⑤ US power lead
- ⑥ Power supply unit

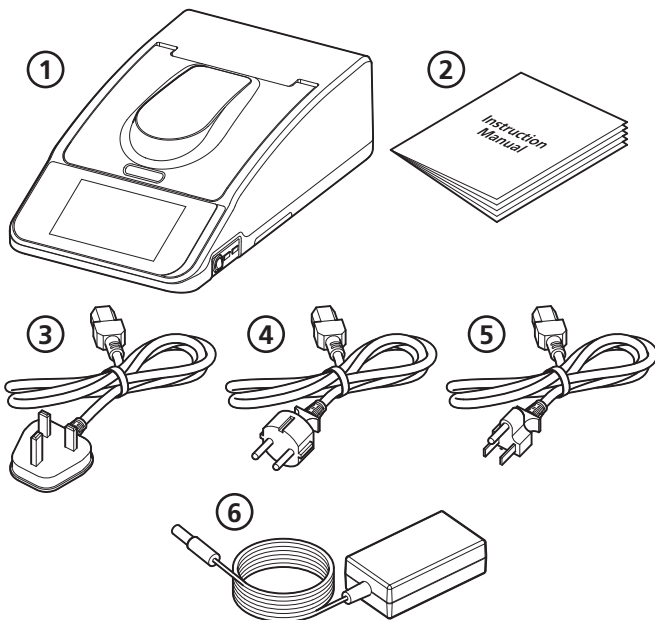

### 2.2 Installation Conditions



When the equipment is used for the first time or moved to a different environmental temperature, it is important to allow the equipment to equalise to the ambient temperature. We recommend you allow the equipment to stand for 2 hours before switching on.

This equipment is designed to operate safely under the following conditions:

- For indoor use only
- Use in a well ventilated area
- Ambient temperature range 5°C to 40°C (41°F to 104°F)\*  
*\*Best results are achieved when the equipment is operated within a temperature range of 15°C to 35°C (59°F to 95°F).*
- Altitude to 2000m (6500 ft)
- Relative humidity not exceeding 80% (temperature 31°C) decreasing to 50% (temperature 40°C) and free from condensation
- Mains supply fluctuations not exceeding 10% of nominal
- Overvoltage category II IEC60364-4-443
- Pollution degree 2 IEC664
- Use with a minimum distance all round of 300mm (12in.) from walls or other items

Place the equipment on a clean, firm, level surface which is free from drafts. Avoid installation on a slippery surface or on a surface prone to vibration or on a surface prone to flooding.

Select the power lead and attach to the power supply unit. Connect the power supply unit to the power inlet socket on the rear panel of the instrument and connect to the mains socket. Ensure that the sample chamber is empty and all packaging material has been removed before turning the power on at the mains and switching the instrument on using the power switch on the side of the instrument.

The equipment will perform several power-on tests and wavelength calibration before displaying the main screen.

## 2.3 Overview

### 2.3.1 Main View

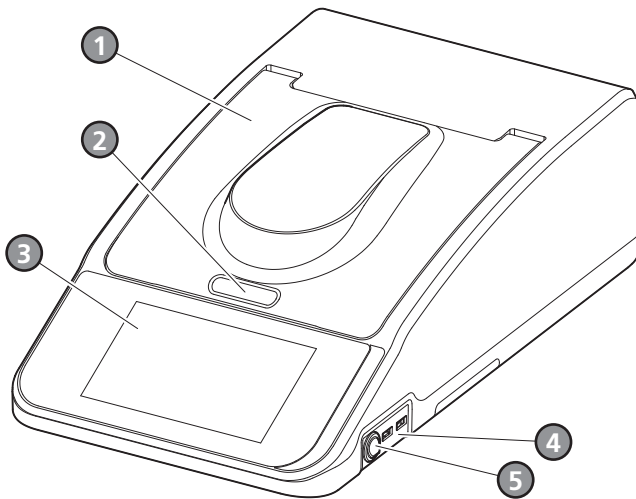

- ① Lid
- ② Open and close catch
- ③ Colour touchscreen and user interface
- ④ 2 x USB Type A ports
- ⑤ On/Off power switch

### 2.3.2 Rear View

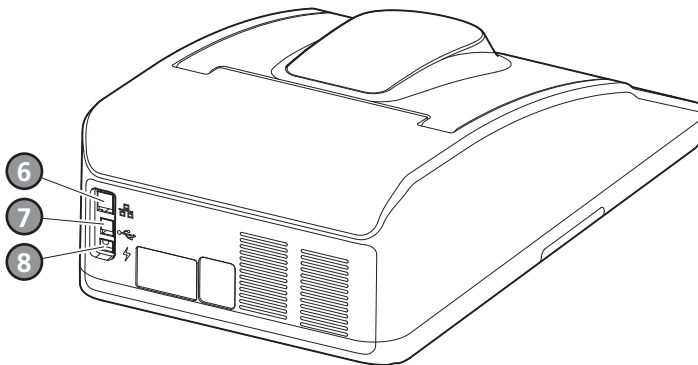

- ⑥ Ethernet (RJ45) port
- ⑦ USB Type B port
- ⑧ Power inlet socket

## Section 3 - Theory and Practice of Spectroscopy Measurement

### 3.1 Theory of Spectroscopy Measurement

UV-visible spectroscopy is the measurement of the absorbance of light at a specific wavelength in a sample. This is used to identify the presence and concentration of molecular entities within the sample. The Beer-Lambert law is used to relate the absorption of light to the properties of the sample through which the light is travelling through. The Beer-Lambert law states that:

$$A = \epsilon l c$$

- A** is the absorbance  
 **$\epsilon$**  is the molar absorption coefficient ( $\text{l mol}^{-1}\text{cm}^{-1}$ )  
**l** is the path length (cm)  
**c** is the concentration ( $\text{mol l}^{-1}$ )

This law shows that absorbance is linear to concentration but this is only true for low concentrations. For absorbance levels above 3 the concentration starts to move away from the linear relationship.

Transmittance is the proportion of the light which passes through the sample:

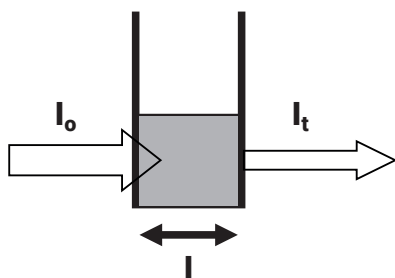

Where:

- $I_o$**  is the incident light  
 **$I_t$**  is the transmitted light  
**l** is the path length

Therefore:

$$T = \frac{I_t}{I_o}$$

Absorbance is inversely related to transmittance:

$$A = \frac{\text{Log } 1}{T}$$

**NOTE:** The SP-500-NANO does not use fixed path length cuvettes. A droplet of sample is placed on the read head and a path length of either 0.2mm or 0.5mm is chosen by the user, see Section 5 - Micro Volume Settings for more information.

### 3.2 Spectroscopy Measurement

There are four main components of a spectrophotometer. These are a light source to emit a high and constant amount of energy over the full wavelength range; a method for separating the light into discrete wavelengths; a sample holder and a light detector.

The optical layout of the SP-500-NANO spectrophotometer is shown below:

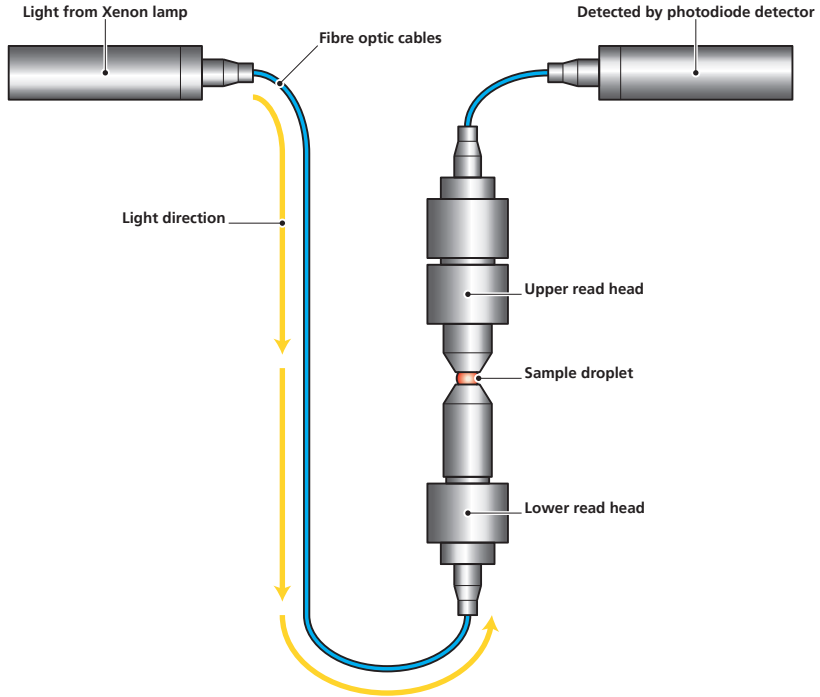

The light from the pre-aligned xenon lamp is focused through a fibre optic cable at 1200 lines per millimetre, which separates the light into discrete wavelengths. Two read heads are connected by fibre optic cables to the light source and detector. A droplet of sample (2-5 $\mu$ l) is placed on the lower read head. The upper read head is then lowered to a defined path length, either 0.5mm or 0.2mm. The defracted light is passed through the sample and the absorbance measured.

Reducing the path length results in a lower absorbance value than with a standard 10mm cuvette, so although smaller volumes can be used, the concentration of the sample needs to be higher to achieve a readable absorbance. The "virtual dilution" is 20-fold at 0.5mm and 50-fold at 0.2mm.

### 3.3 Good Practice Guidelines

1. For optimum performance all spectrophotometers should be sited in a clean, dry, dust free atmosphere. When in use ambient temperature and light levels should remain as constant as possible.
2. If required, adherence to Standard Operating Procedures (S.O.P.) and Good Laboratory Practice (G.L.P.) should be monitored with regular calibration checks and a suitable Quality Control (Q.C.) programme.
3. The sample chamber lid must be fully closed during measurement before any readings are recorded or printed.
4. All measurements require calibration to a blank, for maximum accuracy this should be prepared with care using the same deionised water or solvent used for dissolving or diluting the sample. Where reagents are added to the sample to produce a colour proportional to its concentration a 'sample based' blank should be used. In this case the blank should consist of all reagents or chemicals to be used, except the sample which will produce the colour to be measured.
5. Ensure the read heads are clean. Wipe both the upper and lower read heads with a lint free cloth wetted with deionised water to remove any residues of previous samples. Dry with a fresh cloth.
6. If a stable droplet does not form, "buff" the read head surfaces by rubbing firmly with a dry laboratory wipe 30-40 times. This will "re-condition" the surface.
7. Make sure that the sample is well mixed and free of air bubbles or particles. If a bubble is created when pipetting the sample, remove the sample and repeat the application.
8. If possible use at least 2 $\mu$ l of sample for measurement. When measuring at 0.2mm path length, a minimum of 0.5 $\mu$ l can be used.
9. Read each sample droplet only once. The read head moves into a default position after the sample has been measured. This means that if the sample is measured a second time, contact of the droplet with the read heads could be lost and the subsequent reading will not give a valid result.
10. Use a sample of sufficient concentration. Remember that the short path length creates a "virtual dilution" of the sample of 1 in 20 at 0.5mm and 1 in 50 at 0.2mm. This means that a sample which would normally read an absorbance of 1.0 in a standard 10mm cuvette will only give a value of 0.05 at 0.5mm or 0.02 at 0.2mm.
11. To minimise any factors which may interfere with a reading such as sample turbidity or contaminants carried over from sample preparation, it is recommended that a background reading is also made at a second reference wavelength (where the absorbance of the sample is very low and unchanging).
12. Use the same measurement mode if comparing the concentrations of samples. Different modes use different equations to calculate the final sample concentration.
13. Be aware that when measuring micro volume samples, very small changes in absorbance can lead to much greater differences in calculated concentration values due to the inherent "dilution" factor of the small path length. For example, when measuring dsDNA, an absorbance change of just 0.001 equates to a derived concentration change of 1 $\mu$ g/ml at 0.5mm path length (based on 1 A<sub>260</sub> unit of dsDNA = 50 $\mu$ g/ml).
14. Cole-Parmer recommend that the micro volume accessory is calibrated every 6 months. A set of calibration solutions is available to order (part code 035 092). See Section 20 - Calibration for more information.

## Section 4 - Instrument Set up

### 4.1 Start up Screen

The power up screen is shown below:



### 4.2 Navigation

The main menu is shown below:

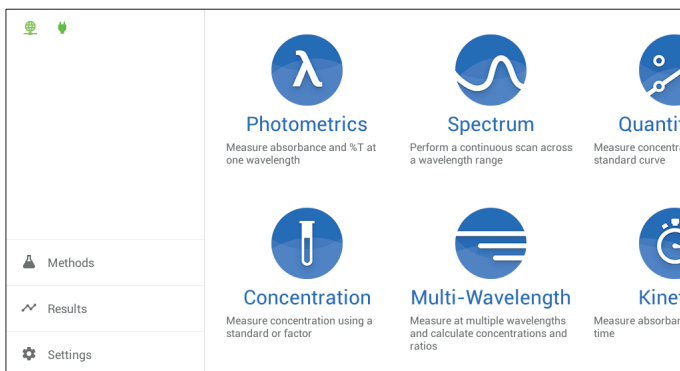

This spectrophotometer is controlled solely through the touchscreen interface of the equipment and follows a basic Android user interface. If the number of options available in a menu exceeds the number that can be displayed on the screen, swipe to the left to view the other modes.



The main menu screen provides access to all Measurement modes, Methods, Results and the Settings menu. Additional icons are displayed when the unit is connected to a network and if an active accessory is installed.

The settings menu enables access to Instrument status, Measurement settings, Network connections Storage, Regional settings and Service settings.

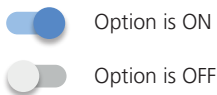
Throughout, the software options can be turned ON and OFF using a switch:



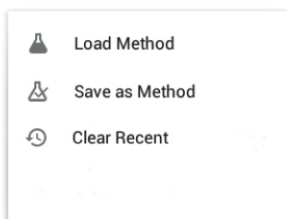

In each measurement mode there is an overflow icon  giving additional save and load method options.

Touching  **Load Method** gives options to load a previously saved method, touch  **Save as Method** to save the entered method parameters, or touch  **Clear Recent** to clear recently used method parameters.

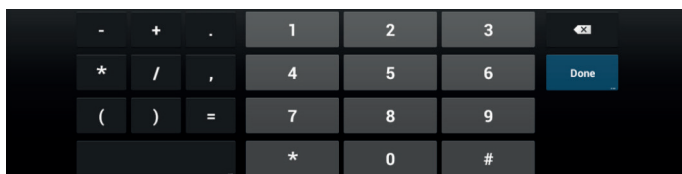

When required to enter numbers, a keypad will pop up. Touch the required numbers and touch **Done** to apply. To exit the keypad without changing the entered value touch **Done** or the minimize icon .



When required to enter letters, a keypad will pop up. Touch the required letters and touch **Save** to apply. To exit the keypad without changing the entered value touch **Save** or the minimize icon .

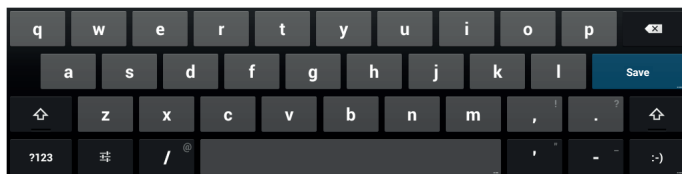

### 4.3 Methods

Touch  **Methods** to access methods that have been saved. Touch the required method to view the details of the method set up. You will then be able to delete, upload, export, edit or run the selected method. See Section 16 - Saving, Loading, Deleting and Printing for more information.

## 4.4 Results

Touch  **Results** to access results that have been saved. Touch the required results to view the details of the result. You will then be able to delete, upload or export the selected result. See Section 16 for more information.

## 4.5 Settings

Touch  **Settings** to enable access to instrument status, measurement settings, network connections, storage and service settings.

### 4.5.1 Instrument Status

Touch  **Measurement settir** to view the status of the spectrophotometer, check connections, fitted accessories, the serial number of the unit and the software version the instrument is using. The language and date and time can also be set here.

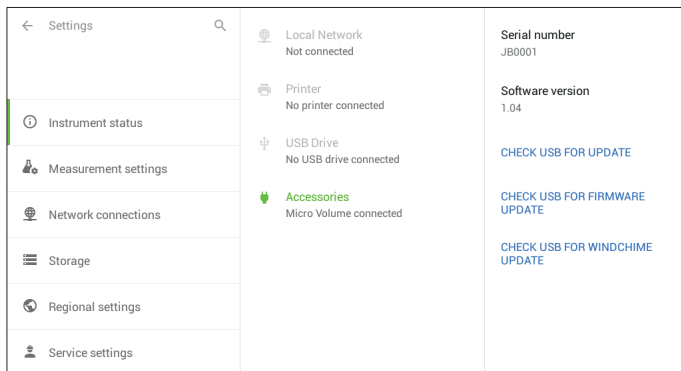



### 4.5.2 Measurement Settings

Touch  **Network connections** to select options for autosave results and the favourites panel.

Slide the **Auto-save Results** button to the  position to automatically save results to the instruments internal memory.

Slide the **Display favourites panel** button to the  position to view favourite panel on the home screen.

Touch **Temperature scale**  
 to choose Celsius or Fahrenheit

Slide the **Feedback & Diagnostics** button to the  position to send anonymous diagnostic and feedback data to Cole-Parmer to help fix and improve software and services.

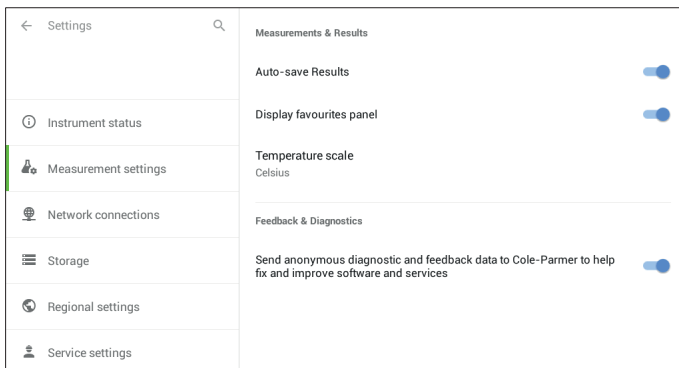

### 4.5.3 Network Connections

Touch  Storage to view available network connections. Options include Ethernet (RJ45), IP configuration, Status, IP address. Note: CPLive is no longer supported.

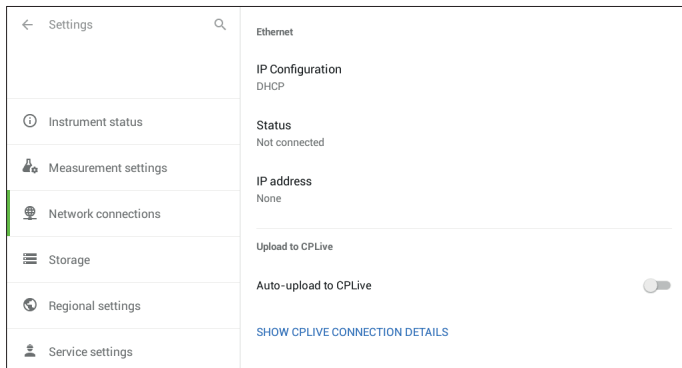

### 4.5.4 Storage

Touch  Regional to view the amount of available storage on the internal memory of the spectrophotometer. If a USB memory stick is inserted the amount of free space on the USB stick will also be shown.

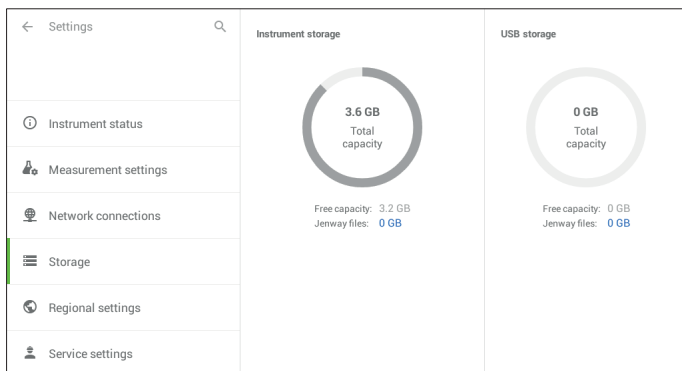

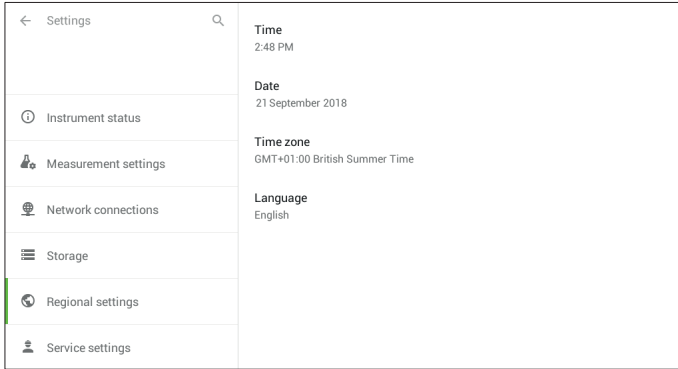

## 4.5.5 Regional Settings

Touch  **Regional settings** to view the Time, Date, Time zone and Language options.



### 4.5.5.1 Setting the Time

To set the instrument time touch **Time**  **2:48 PM**. Touch **02** and move the clock hand  **2** to the correct hour position, repeat the same process for minutes, select AM or PM and touch **OK** to apply. Touching **CANCEL** will return to the instrument settings screen without altering the time. The set time will be displayed in each measurement mode and will be recorded against saved methods and results.

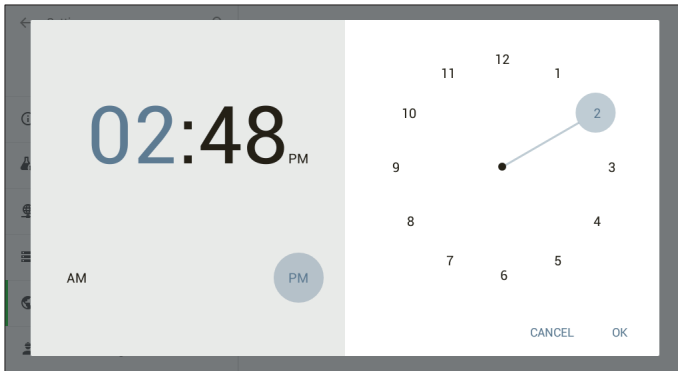

### 4.5.5.2 Setting the Date

To set the instrument date touch **Date** 21 September 2018 . Scroll up or down to change the month viewed. Touch the required date **21** and touch **OK** to apply. To set the year touch **2018** and scroll up or down and touch the required date **2018** and touch **OK** to apply. Touching **CANCEL** will return to the instrument settings screen without altering the date. The set date will be displayed in each measurement mode and will be recorded against saved methods and results.

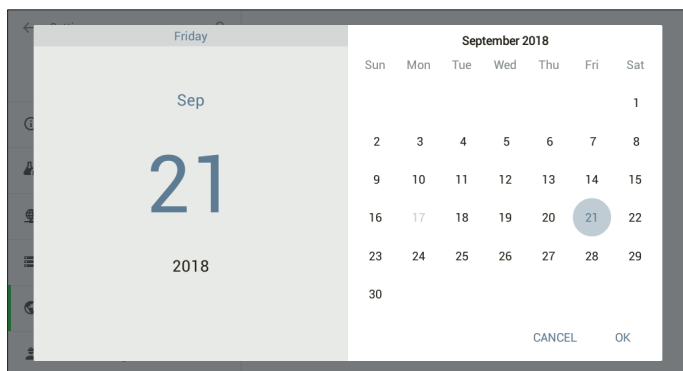

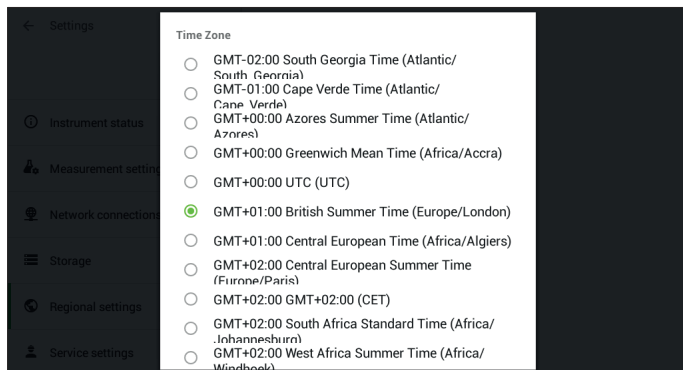

### 4.5.5.3 Setting the Time Zone

To set the instrument time zone touch **Time zone** GMT+01:00 British Summer Time . Scroll up or down to locate the required time zone and touch  next to the required time zone to apply.



#### 4.5.5.4 Instrument Language

The software can be viewed in five different languages with a choice of English, French, German, Italian or Spanish. To select the required language touch  and select from the menu. Touch  next to the required language to apply.

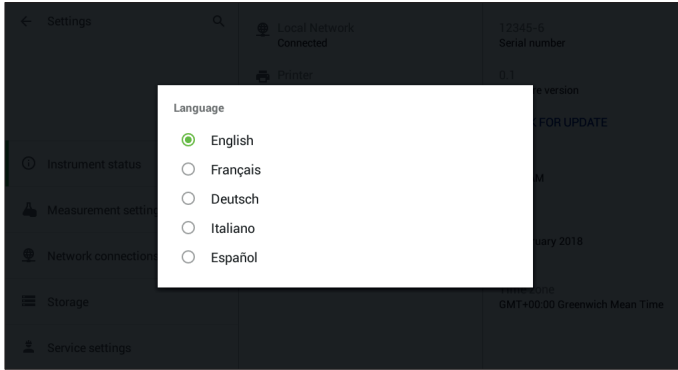

#### 4.5.6 Service Settings

Service Settings are protected from normal use. They must only be accessed by service engineers only.

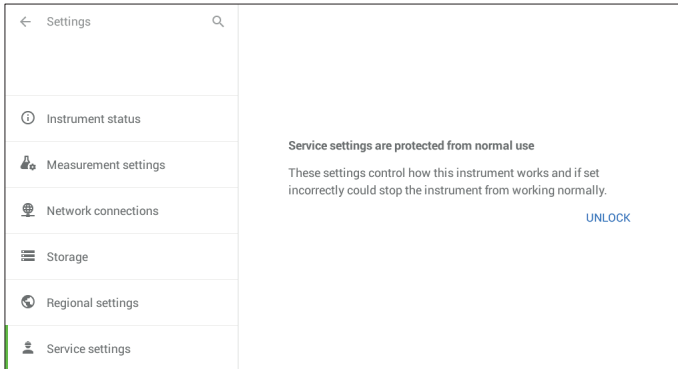



## Section 5 - Micro Volume Settings

The Micro Volume Settings allows the user to select the required path length (0.2mm or 0.5mm) for a measurement and to calibrate the accessory using a standard solution with known absorbance values at 260 and 330nm.



Cole-Parmer recommends that users select the required path length before the start of each experiment.

**NOTE:** Factory default is 0.2mm.

The Micro Volume icon  is displayed at the top of the screen in each measurement mode. Touch  to access the Micro Volume settings.

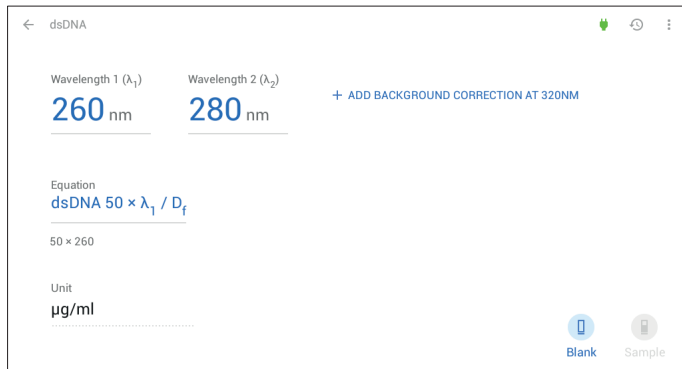

← dsDNA

Wavelength 1 ( $\lambda_1$ )      Wavelength 2 ( $\lambda_2$ )  
**260 nm**      **280 nm**      + ADD BACKGROUND CORRECTION AT 320NM

Equation  
**dsDNA  $50 \times \lambda_1 / D_f$**

50 × 260

Unit  
**µg/ml**

Blank      Sample

Touch <sup>Path Length</sup> 0.2 mm to access path length selection.

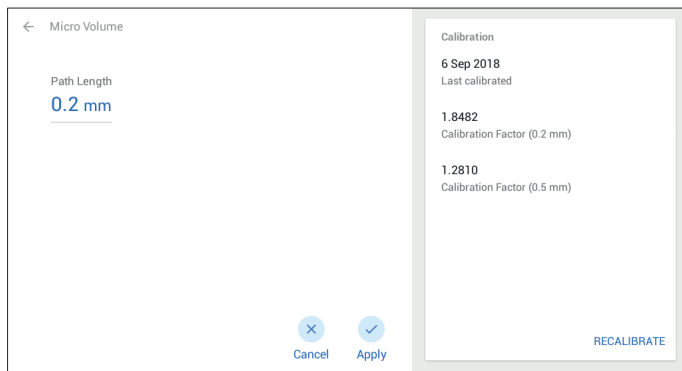

← Micro Volume

Path Length  
**0.2 mm**

Calibration  
**6 Sep 2018**  
Last calibrated

**1.8482**  
Calibration Factor (0.2 mm)

**1.2810**  
Calibration Factor (0.5 mm)

Cancel      Apply      RECALIBRATE

Touch the path length you require and then  to confirm.



Path Length

0.2 mm

0.5 mm

## Section 6 - Adding, Removing and Recovering Samples

### 6.1 Adding a Sample

The SP-500-NANO spectrophotometer is designed to measure sample volumes ranging from 0.5µl to 5.0µl. Cole-Parmer recommends that users should, if possible use at least 2.0µl of sample for their measurements.

Open the lid of the spectrophotometer and the **Read Head Mechanism** will open. Pipette the liquid to be analysed onto the centre of the **Lower Read Head**. Ensure there are no bubbles in the sample.

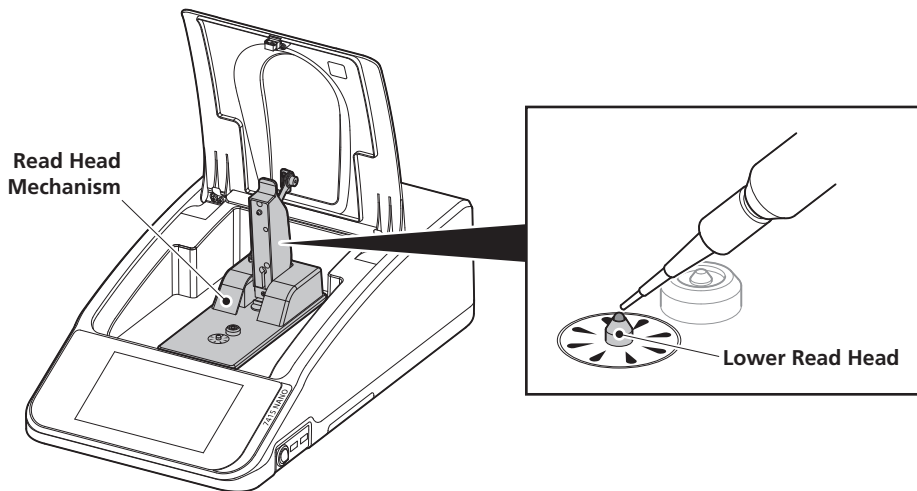

Close the lid of the spectrophotometer and the read head mechanism will lower down onto the path length drive motor. The **Upper Read Head** is now in the rest position, 2mm above the **Lower Read Head**.

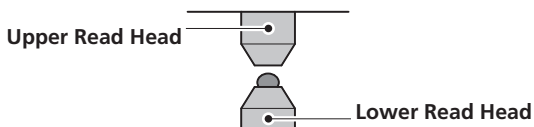

When a measurement is initiated the path length drive motor lowers the **Upper Read Head** to a specified distance.

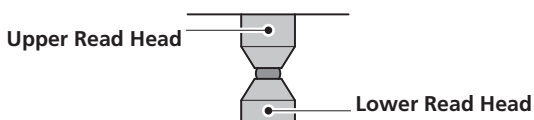

The photometric measurement is taken and the upper read head will return to the rest position.

### 6.2 Removing a Sample

Once a measurement is complete, open the lid of the spectrophotometer and the read head mechanism will open. The sample can be removed from the upper and lower heads by cleaning with a suitable lint free cloth.

More rigorous cleaning may be required after the measurement of high concentration samples that pose a contamination risk. See Section 18 - Maintenance and Servicing for more information.

### 6.3 Recovering a Sample

Once a measurement is complete, open the lid of the spectrophotometer and the read head mechanism will open. The sample can be recovered by carefully drawing the liquid that is retained on the lower head with a suitable, clean pipette. The upper and lower read heads can be wiped clean with a suitable lint free cloth.

More rigorous cleaning may be required after the measurement of high concentration samples that pose a contamination risk. See Section 18 - Maintenance and Servicing for more information.

## Section 7 - Photometrics



Cole-Parmer recommends that users select the required path length before the start of each experiment. See Section 5 - Micro Volume Settings for more information.

The photometrics measurement mode enables simple measurements of absorbance and % transmittance to be performed. The sample is measured at one wavelength and at one point in time. There are no post measurement calculations available in this measurement mode. Touch the Photometrics icon on the main menu to enter this measurement mode.

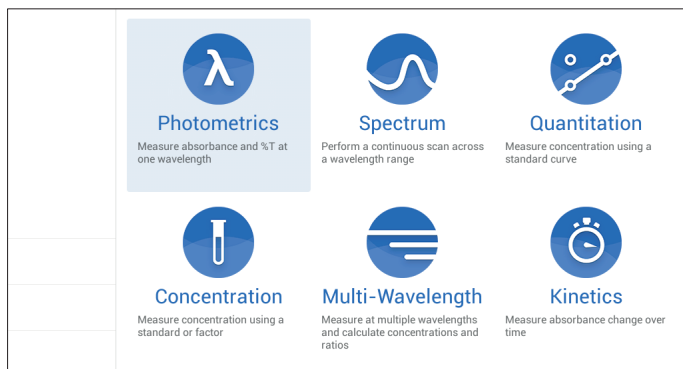

### 7.1 Method Set up

This measurement mode is very simple and the only parameter which can be adjusted is the wavelength. Once the required wavelength has been entered a calibration can be performed.

#### 7.1.1 Selecting a Wavelength

To adjust the wavelength, touch **Wavelength** 400 nm and use the keypad to enter the required wavelength. Touch **Done** to apply the entered wavelength and return to the method set up.

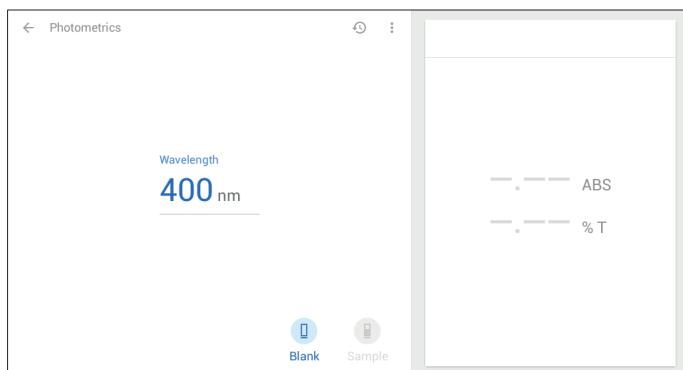



## 7.2 Blank Measurement

A blank measurement must be performed at the same wavelengths at which the sample will be measured. Open the spectrophotometer lid and pipette the blank solution onto the lower read head and close the lid.

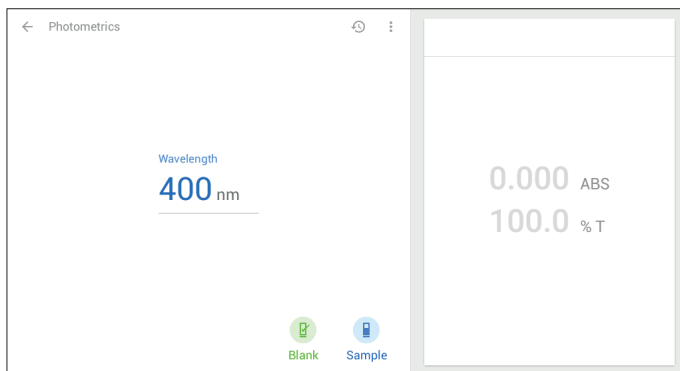
Touch  and the instrument will calibrate to zero absorbance and 100% transmittance.



## 7.3 Sample Measurement

Once a blank measurement has been performed  will become active and a sample can be measured. Remove the blank solution by cleaning the upper and lower read heads. Pipette the sample to be analysed onto the lower read head and close the lid. Touch  to begin measurement.

Once the measurement is complete the results will be shown on the screen.

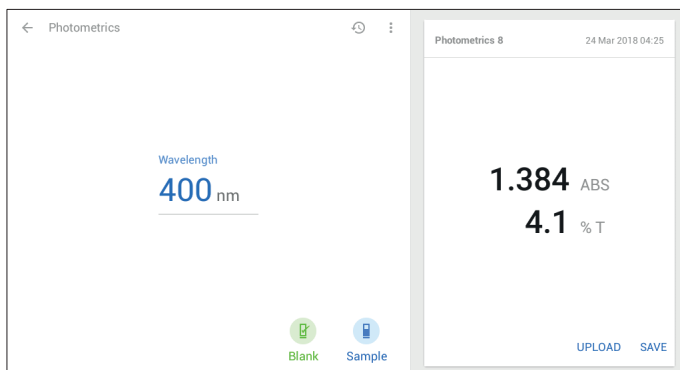

Touch  to measure subsequent samples in the same way.

If any of the parameters are adjusted between sample measurements you will need to perform another blank measurement before more samples can be measured.

## Section 8 - Concentration

The concentration measurement mode enables sample concentrations to be calculated using a standard of a known concentration or a known factor. The sample is measured at one wavelength at one point in time. There are no post measurement calculations available in this measurement mode. Touch the Concentration icon on the main menu to enter this measurement mode.

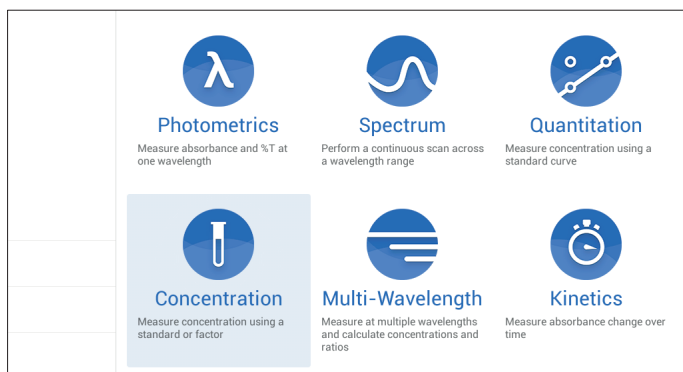

### 8.1 Method Set up

The parameters which can be entered in this measurement mode are wavelength, factor or standard concentration and units of concentration. Once all the required parameters have been entered a calibration can be performed.

#### 8.1.1 Selecting a Wavelength

To adjust the wavelength, touch <sup>Wavelength</sup> 400 nm and use the keypad to enter the required wavelength. Touch **Done** to apply the entered wavelength and return to the method set up.

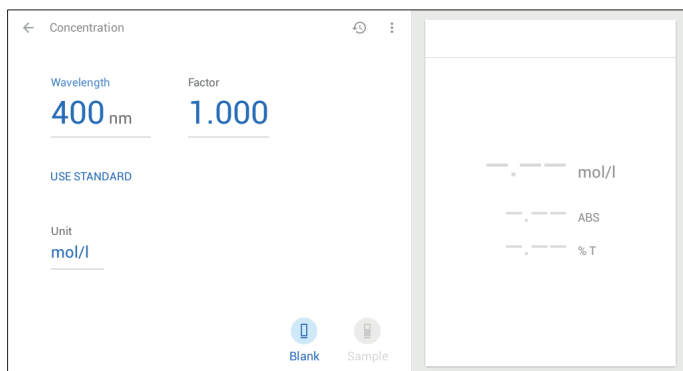

#### 8.1.2 Using a Factor

If the factor is known, there is no need to measure a standard of known concentration. Touch <sup>Factor</sup> 1.000 and use the keypad to enter the required factor. Touch **Done** to apply the entered factor and return to the method set up.

### 8.1.3 Using a Standard

If the factor is not known a standard of known concentration can be measured to calculate concentration. Touch **USE STANDARD** to select this option and disable the use factor option. To enter the concentration of the known standard touch the value under standard  $500 \text{ mol/l}$   $\times$  and use the keypad to enter the required concentration value. Touch **Done** to apply this concentration and return to the method set up. To return to using a factor touch the  $\times$  icon and the use standard option will be disabled.

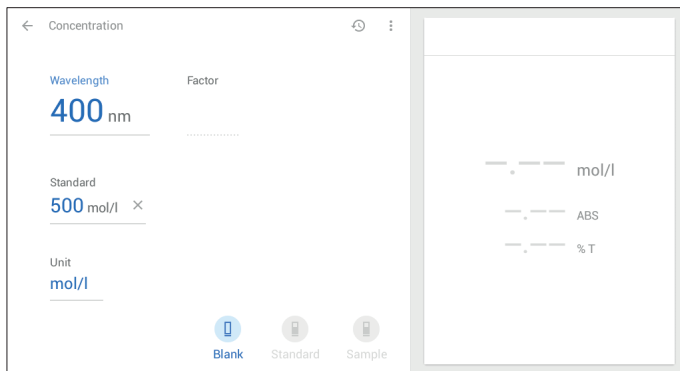

### 8.1.4 Selecting Concentration Units

The units of concentration can be selected from several options. Touch  $\text{Unit mol/l}$  to select from the menu. Touch the circle  $\bigcirc$  adjacent to the required unit of concentration. The selected unit will be displayed against the final concentration result.

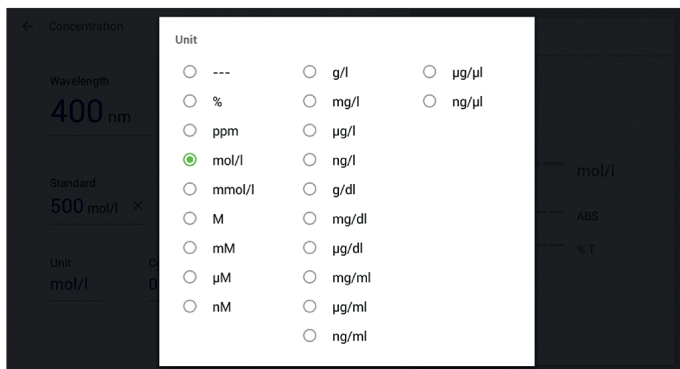

## 8.2 Blank Measurement

A blank measurement must be performed at the same wavelength at which the sample will be measured. There are two options depending on if a standard or factor was selected in the method set up.

### 8.2.1 Calibrating to a Factor

If a Factor has been entered, only a blank measurement is required. Open the spectrophotometer lid and pipette the blank solution onto the lower read head and close the lid. Touch  and the instrument will calibrate to zero absorbance and 100% transmittance.

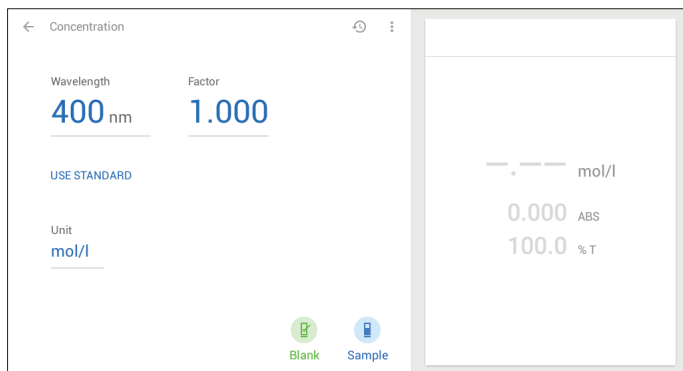

Once a blank measurement has been performed  icon becomes active and the sample can be measured.



### 8.2.2 Calibrating to a Standard

Open the spectrophotometer lid and pipette the blank solution onto the lower read head and close the lid.

Touch  and the instrument will calibrate to zero absorbance and 100% transmittance.

If a standard concentration has been entered the  icon will become active. Remove the blank solution by cleaning the upper and lower read heads. Pipette the known standard solution onto the lower read head and close the lid. Touch the  icon and the instrument will measure the absorbance of the standard sample.

Once the calibration using a standard is complete the unknown sample can be measured and the  icon becomes active.

The spectrophotometer will calculate the factor so that this value can be used for future measurements.

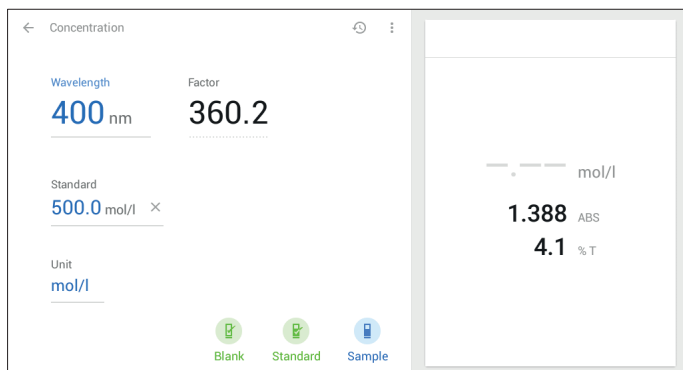

### 8.3 Sample Measurement

It is not possible to perform sample measurements before the instrument has been calibrated at the selected wavelength.

#### 8.3.1 Measuring a Sample After Calibrating to a Factor

Remove the blank solution by cleaning the upper and lower read heads. Pipette the sample to be analysed onto the lower read head and close the lid. Touch  to begin measurement.

Once the measurement is complete the results will be shown on screen.

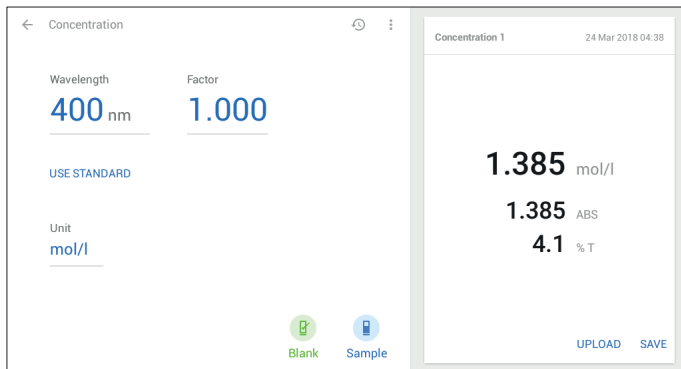

#### 8.3.2 Measuring a Sample After Calibrating to a Standard

Remove the standard solution by cleaning the upper and lower read heads. Pipette the sample to be analysed onto the lower read head and close the lid. Touch  to begin measurement.

Once the measurement is complete the results will be shown on screen..

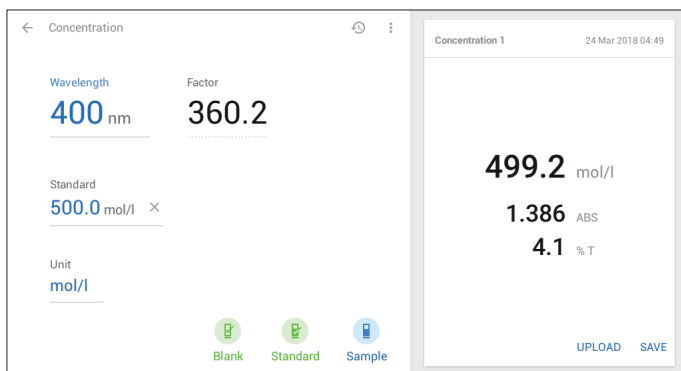

## Section 9 - Spectrum

The spectrum measurement mode enables measurements of absorbance or % transmittance over a range of wavelengths to be performed. The absorbance or % transmittance at each wavelength is plotted graphically. Post measurement tools such as peaks and valleys analysis and area under the graph can be performed. This operating mode can be used to partially characterise a sample. Touch the Spectrum icon on the main menu to enter this measurement mode.

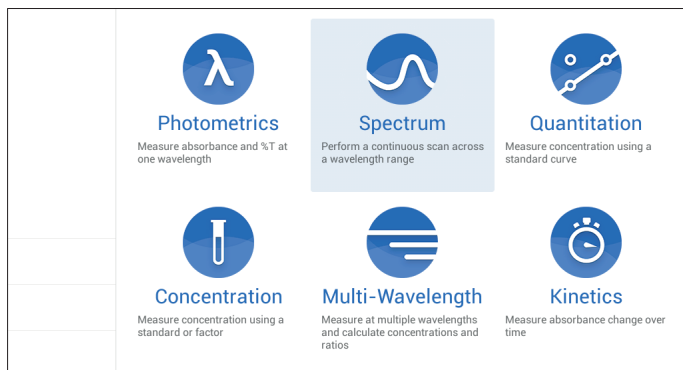

### 9.1 Method Set up

The parameters which can be entered in this measurement mode are start and end wavelength, scan interval and measurement mode. Once all the required parameters have been entered a calibration can be performed.

#### 9.1.1 Setting Start and End Wavelengths

The SP-500-NANO can perform measurements from 198nm to 1000nm. To adjust the start wavelength, touch Start wavelength **400** nm and use the keypad to enter the required wavelength. Touch **Done** to apply the entered wavelength and return to the method set up. The end wavelength can be adjusted in the same way.

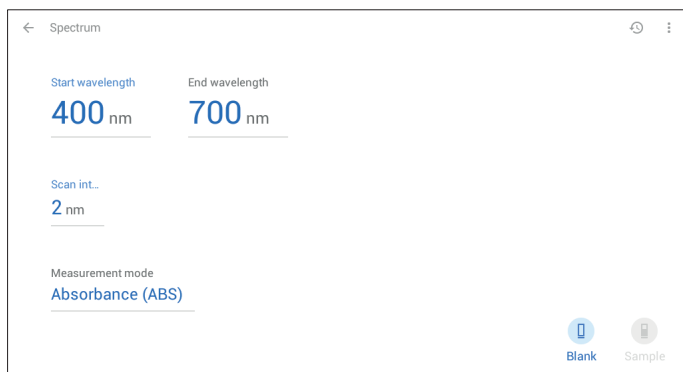

The start and end wavelengths must be different. If the same value is entered an error message will be displayed.

Start wavelength must be lower than End wavelength

### 9.1.2 Setting the Scan Interval

This function enables the interval between wavelengths measured in the spectrum scan to be set. The scan interval can be altered to 1, 2, 5 or 10nm by touching the value below scan interval Scan int.. 2 nm . Select the required scan interval from the available options. Touch the  adjacent to the required interval to apply. The scan interval can only be selected if the wavelength range is divisible by this number. For example a scan interval of 5nm cannot be selected for a wavelength range of 400 to 503nm.

### 9.1.3 Selecting Absorbance or % Transmittance

The default operating mode is absorbance. To change this between absorbance or % transmittance, touch Measurement mode Absorbance (ABS) Or Measurement mode Transmittance (% T) to select the required measurement mode. Repeat touches will cycle between the two options.



## 9.2 Blank Measurement

A blank measurement must be performed across the same wavelength range as the sample will be measured across. Open the spectrophotometer lid and pipette the blank solution onto the lower read head and close the lid.

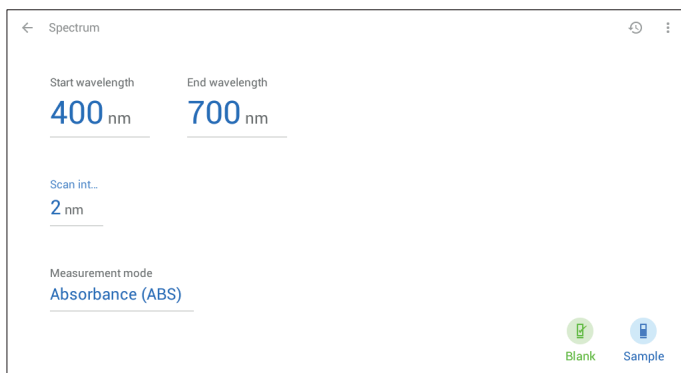
Touch  to initiate the baseline scan. The instrument will calibrate to zero absorbance and 100% transmittance across the wavelength range and scan interval.



## 9.3 Sample Measurement

Once a blank measurement has been performed  will become active and a sample can be measured. Remove the blank solution by cleaning the upper and lower read heads. Pipette the sample to be analysed onto the lower read head and close the lid. Touch  to begin measurement.

Once the measurement is complete the results will be shown on the screen.

Touch **RUN AGAIN** to measure subsequent samples in the same way.

If any of the parameters are adjusted between sample measurements you will need to perform another blank measurement before more samples can be measured..

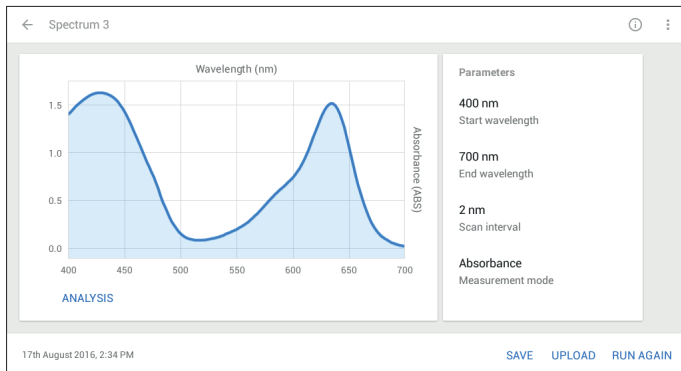

Once the spectrum scan is completed it is possible to analyse the spectrum scan. Post measurement tools include peaks and valleys and area under the curve. To analyse the data touch **ANALYSIS**.

## 9.4 Data Analysis

Touching the spectrum scan will open a sliding cursor . Slide the cursor across the scan to show the absorbance or %T value at any wavelength.

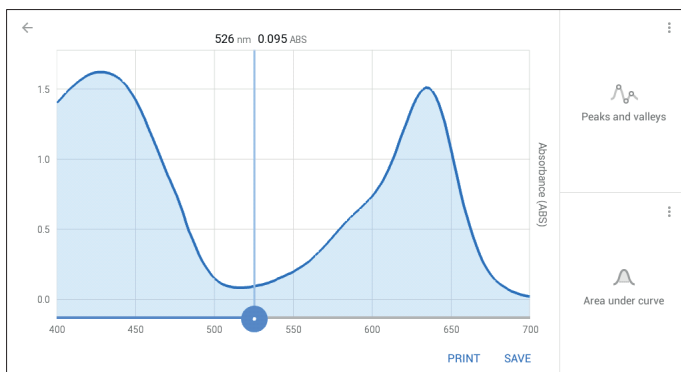

### 9.4.1 Peaks and Valleys

To view the peaks and valleys touch . The peaks and valleys table displays all the detected peaks and valleys above the selected threshold value.



Touch and slide  to change the threshold level. The graph can be zoomed in and out by pinching two fingers on the screen.

To add a point to the list touch the spectrum scan to open a sliding cursor . Slide the cursor across the scan to the required position or touch the scan. Touch **+ ADD POINT** and the point will be added to the scan and the list.

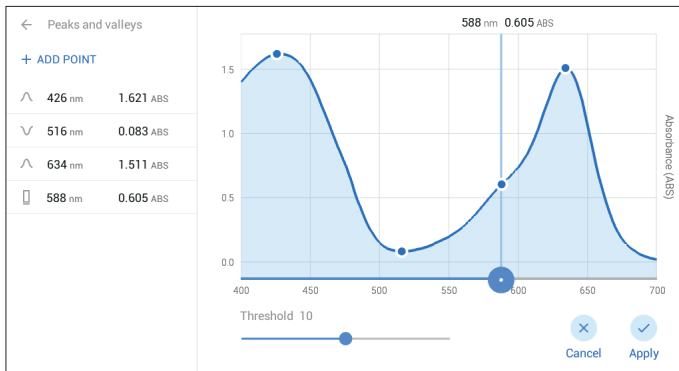

Touch  to return to data analysis screen and remove any added points.



## 9.4.2 Area Under Curve



To view the area under the curve touch . The default mode is baseline. To change this between baseline and tangent, touch  or  to select the required measurement mode. Repeat touches will cycle between the two options.

### 9.4.2.1 Area Under Curve - Baseline Mode

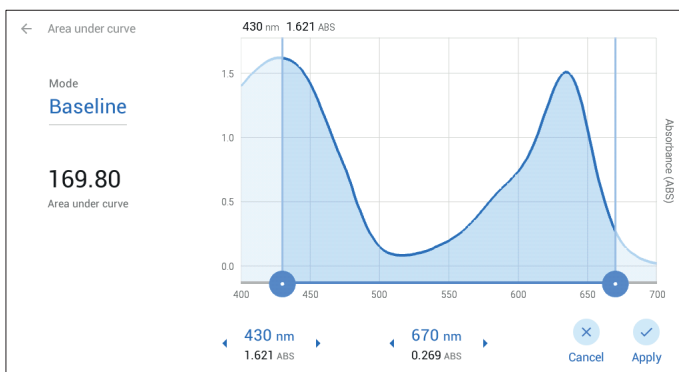
Baseline will calculate the area under the curve between the two sliding cursors . Slide the cursors to select the area required. You can also use the arrows   to move the selected area.



### 9.4.2.2 Area Under Curve - Tangent Mode

Tangent will calculate the area under the curve from the point where each of the two sliding cursors  crosses the spectrum scan. Slide the cursors to select the area required. You can also use the arrows   to move the selected area.

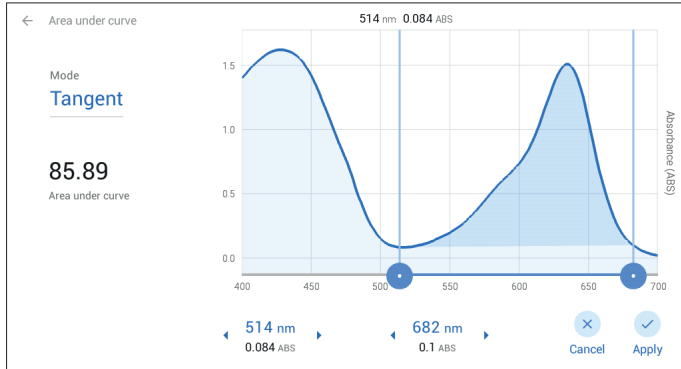

## Section 10 - Quantitation

The quantitation measurement mode enables sample concentrations to be calculated using a standard curve. In this mode a number of standard solutions covering a range of known concentrations are measured at a set wavelength. The absorbance or % transmittance of these solutions is plotted to create a standard curve. Once the standard curve has been created a sample of unknown concentration can be measured and the concentration calculated using the standard curve. Touch the Quantitation icon on the main menu to enter this measurement mode.

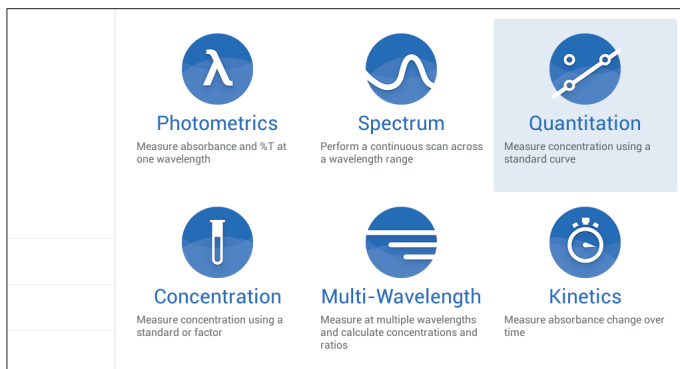

### 10.1 Method Set up

The parameters which can be entered in this measurement mode are the wavelength, number of replicates for the calibration standards and concentration units of the calibration standards.

#### 10.1.1 Selecting a Wavelength

To adjust the wavelength, touch <sup>Wavelength</sup> **400** nm and use the keypad to enter the required wavelength. Touch **Done**

to apply the entered wavelength and return to the method set up. The wavelength selected needs to be the same for the measurement of the standards as for the unknown sample.

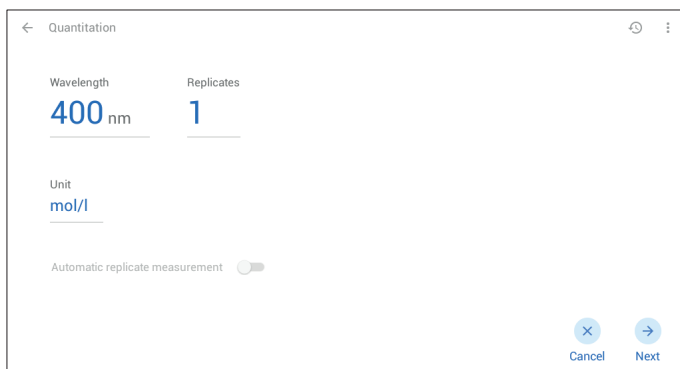

### 10.1.2 Selecting Number of Replicates

Replicates

To select the number of repeat measurements of a calibration standard touch **1**. Touch the circle  adjacent to the required unit of replicates to apply and return to the method set up.

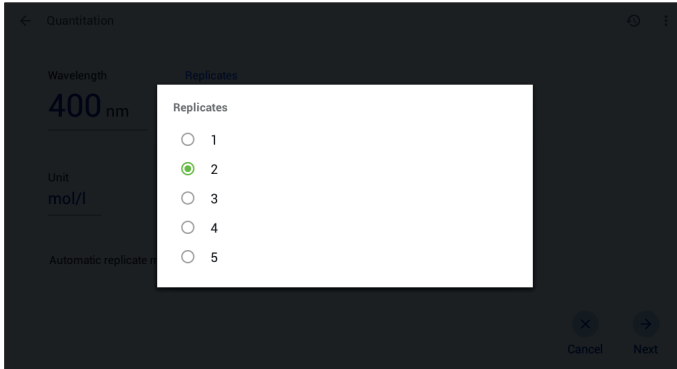

If 2 or more replicates are selected, **Automatic replicate measurement**  becomes active. Automatic replicates will read the same sample for the selected number of replicates. If individual sample replicates are being used, do not select the automatic replicates option.

### 10.1.3 Selecting Concentration Units

The units of concentration can be selected from several options. Touch **µg/ml** to select from the menu. Touch the circle adjacent to the required unit of concentration. The selected unit will be displayed against the final concentration result.

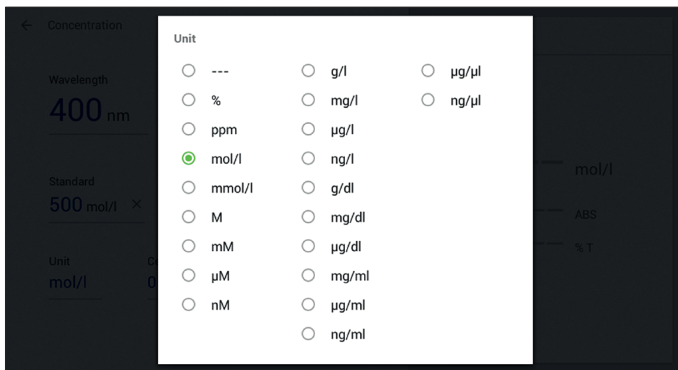

Once the method parameters have been entered touch **Next** to start measuring the calibration standards. Touch **Cancel** to return to the home screen.

## 10.2 Measuring Calibration Standards

The measured standards are used to create a calibration curve. If there is only one standard available the concentration measurement mode should be used. Touch **ADD STANDARD** to add the first standard.

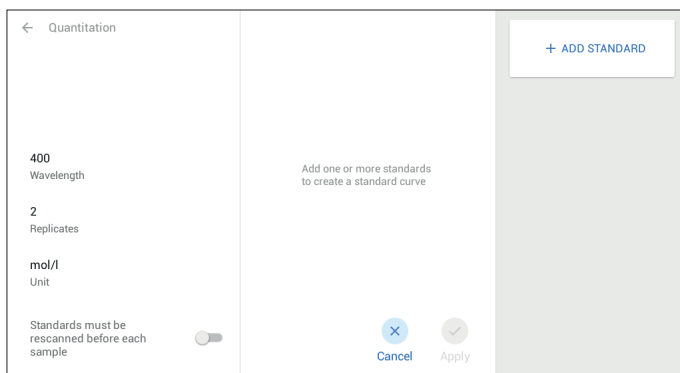

Touch **Concentration** **100 mol/l** to use keypad to enter the concentration value required for that standard. Touch **Done** to apply.

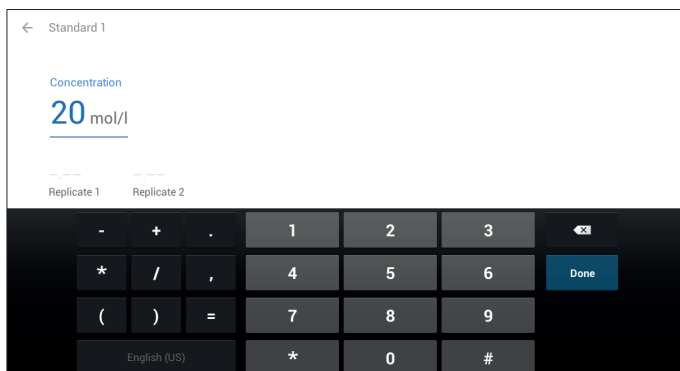

Before the 1st standard can be measured you will need to perform a blank measurement. Open the spectrophotometer lid and pipette the blank solution onto the lower read head and close the lid. Touch **Blank** and the instrument will calibrate to zero absorbance and 100% transmittance.



Once the blank measurement is complete **Standard** will become active, remove the blank solution by cleaning the upper and lower read heads and then pipette the 1st known standard solution onto the lower read head and close the lid. Touch **Sample** to measure the standard.

If there are 2 or more replicates, measure the 1st replicate and then replace it with the next replicate and measure. Repeat this process until all replicates have been measured.

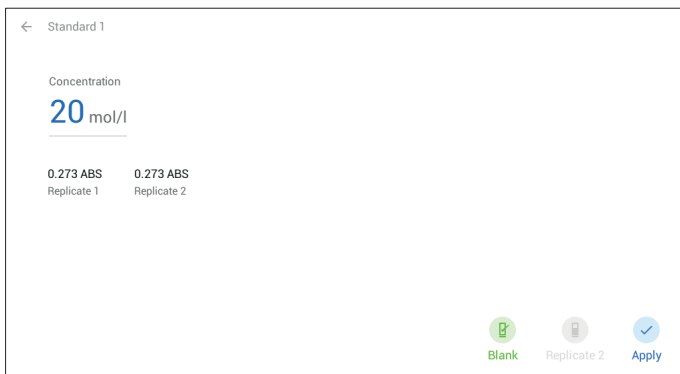
If using **Automatic replicate measurement** , the same standard will be read for the selected number of times.



Touch  to save the absorbance results for the 1st standard.

Touch **+ ADD STANDARD** to add another standard and use the keypad to enter the concentration value required. This time a blank measurement is not required so  is active straight away. Pipette the 2nd known standard solution onto the lower read head and close the lid. Touch  to measure the standard.

If there are 2 or more replicates, measure the 1st replicate and then replace it with the next replicate and measure. Repeat this process until all replicates have been measured.

If using **Automatic replicate measurement** , the same standard will be read for the selected number of times.

Touch  to save the absorbance results for the 2nd standard.

Repeat the above process for the number of standards required to create the calibration curve.

A calibration curve can be set up in advance and concentrations saved for future use without measuring the absorbance values. When the quantitation assay is next performed, each standard is read to calculate the standard curve. To activate this turn **Standards must be rescanned before each sample**  to on. This can aid in the preparation of frequently used quantitation assays.

### 10.3 Standard Curve

Following the measurement of each standard the calibration curve is displayed.

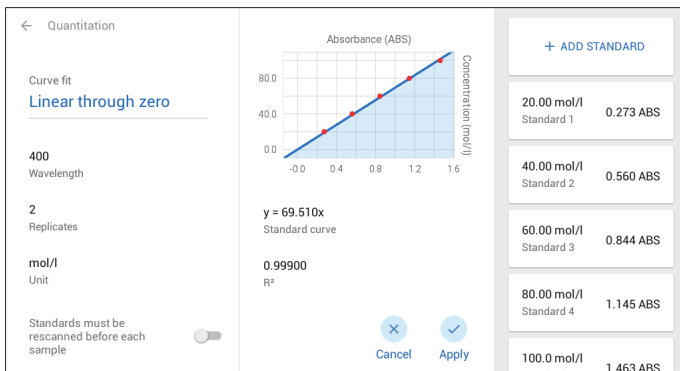

Specific points can be selected on the graph by touching the graph, a sliding cursor will appear. It is possible to move the cursor by dragging left or right.

The curve fit algorithm can be changed by touching **Linear through zero** . Select between linear through zero, linear, quadratic through zero and quadratic.

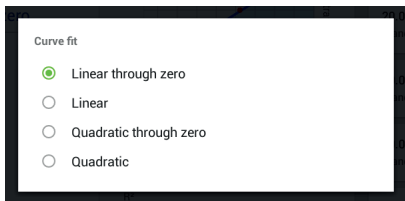

The curve statistics are also displayed for the curve fit chosen. For example if the curve fit is  $y = mx+c$  the curve statistics displayed will be the gradient of the line (m), constant (c) and correlation coefficient ( $r^2$ ).

Once all the standards have been measured touch  and then the unknown samples can be measured.

### 10.4 Sample Measurement

Ensure the upper and lower read heads are clean and pipette the sample to be measured onto the lower read head, close the lid and touch  .

Once the measurement is complete the results will be shown on the screen.

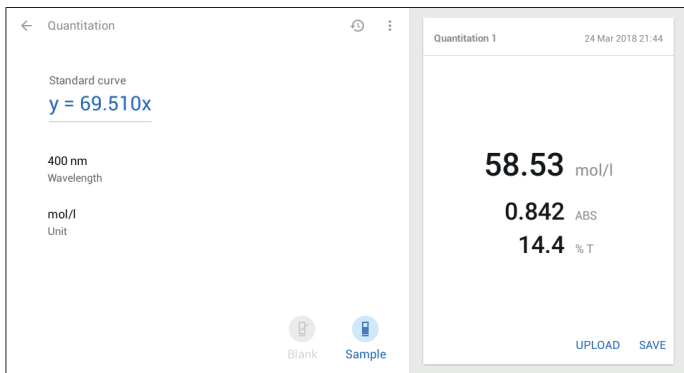

Touch  to measure subsequent samples in the same way.

If any of the parameters are adjusted between sample measurements you will need to perform another blank measurement and a new standard curve must be created before more samples can be measured.

To change the curve fit at any time touch   $y = 69.510x$  to return to the standard curve screen.

## Section 11 - Kinetics

The kinetics measurement mode enables the absorbance or % transmittance of an active molecule to be measured over a set time; for example, enzyme activity. The absorbance or % transmittance is measured at regular time intervals at one wavelength over time. The results are plotted on a graph to show the change in absorbance or % transmittance over time. Following sample measurements analysis of all or part of the experiment can be performed

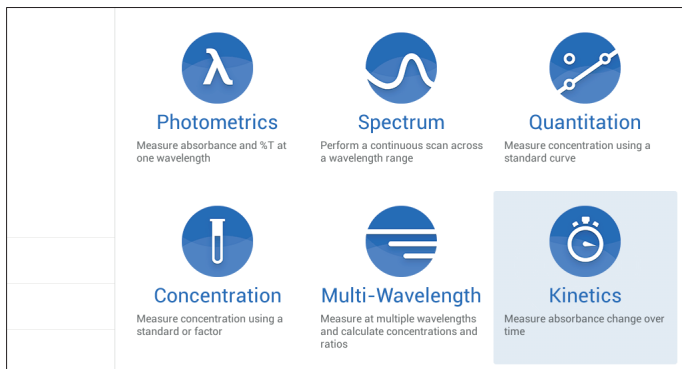

### 11.1 Method Set up

The parameters which can be entered in this measurement mode are wavelength, run time, measurement time interval, lag time, absorbance or % transmittance measurement mode, and the concentration parameters. Once all the required parameters have been entered a calibration can be performed.

#### 11.1.1 Selecting a Wavelength

The wavelength can be adjusted by touching the wavelength value **400** nm <sup>Wavelength</sup> and using the keypad to enter the required wavelength. Touch **Done** to apply the entered wavelength and return to the method set up.

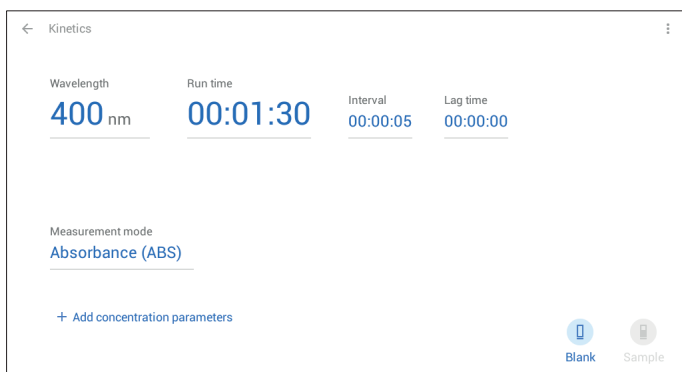

### 11.1.2 Setting the Kinetics Measurement Time

To set the total kinetics measurement time touch <sup>Run time</sup> **00:01:30** and enter the required run time. Scroll up or down beneath Hours, Minutes, Seconds to select the required time and touch **OK** to apply. Touch **CANCEL** to exit the run time set up without saving the changes.

### 11.1.3 Setting the Measurement Time Interval

This is the time that the instrument waits between each measurement during the kinetics run. If it is set to zero then the instrument will perform a measurement at every second during the kinetics run. For example if the run time is 1 hour and the interval is 60 seconds, then the instrument will perform a reading every 60 seconds during the kinetics run.

To set the interval time touch <sup>Interval</sup> **00:00:05**. Scroll up or down beneath Hours, Minutes, Seconds to select the required time and touch **OK** to apply. Touch **CANCEL** to exit the interval time set up without saving the changes.

**NOTE:** Minimum interval is 00:00:01

### 11.1.4 Setting Lag Time

In this measurement mode starting the kinetics measurements can be delayed by setting a lag time. The lag time is the amount of time that the instrument will wait before starting the kinetics measurements after the Sample icon has been touched.

To set the lag time touch <sup>Lag time</sup> **00:00:00**. Scroll up or down beneath Hours, Minutes, Seconds to select the required time and touch **OK** to apply. Touch **CANCEL** to exit the lag time set up without saving the changes.

### 11.1.5 Selecting Absorbance or % Transmittance

The default operating mode is absorbance. To change this between absorbance or % transmittance, touch <sup>Measurement mode</sup> **Absorbance (ABS)** or <sup>Measurement mode</sup> **Transmittance (% T)** to select the required measurement mode. Repeat touches will cycle between the two options.

### 11.1.6 End Point Concentration

Following the kinetics run the end point concentration can be calculated using the absorbance value at the end of the kinetics run. Any point can also be selected so that the concentration can be calculated at any time in the kinetics run. A factor is used to calculate concentration.

Touch **+ Add concentration parameters** for access to factor and units. To adjust factor touch <sup>Factor</sup> **1.000** and use the keypad to enter the required factor. Touch **Done** to apply the entered factor and return to the method set up.

The units of concentration can be selected from several options. Touch <sup>Unit</sup> **mol/l** to select from the menu. Touch the circle  adjacent to the required unit of concentration. The selected unit will be displayed against the final concentration result.

Touch  **Apply** to apply the concentration parameters and return to method set up.





## 11.2 Blank Measurement

A blank measurement must be performed at the same wavelengths at which the sample will be measured. Open the spectrophotometer lid and pipette the blank solution onto the lower read head and close the lid. Touch

 and the instrument will calibrate to zero absorbance and 100% transmittance.

## 11.3 Sample Measurement

Once a blank measurement has been performed  will become active and a sample can be measured. Remove the blank solution by cleaning the upper and lower read heads. Pipette the sample to be analysed onto the lower read and close the lid. Touch  to begin measurement.

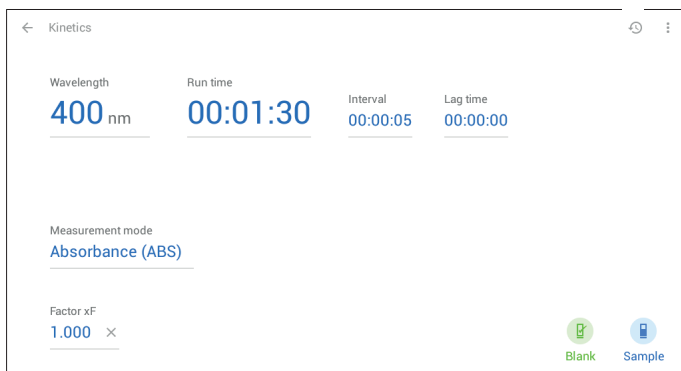

If a lag time has been set the instrument will count down the lag time before the kinetics run starts. If no lag time has been set the kinetics run starts straight away and a live kinetics run is shown on the screen.

If the kinetics run needs to be stopped touch . A warning message will appear asking for confirmation to stop the kinetics run. Touch **OK** to stop the run, touch **CANCEL** to carry on with the kinetic run.

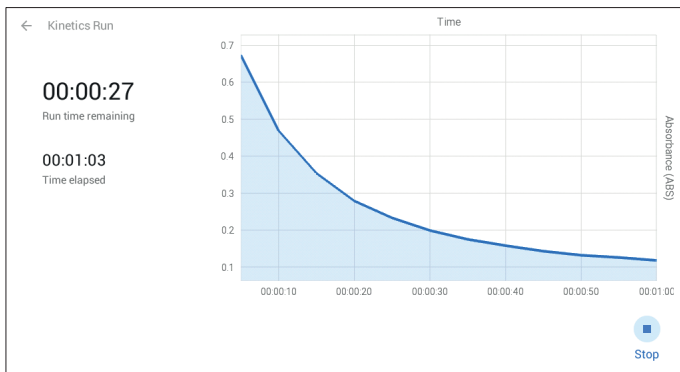

Once the measurement time is complete the results will be shown on the screen.

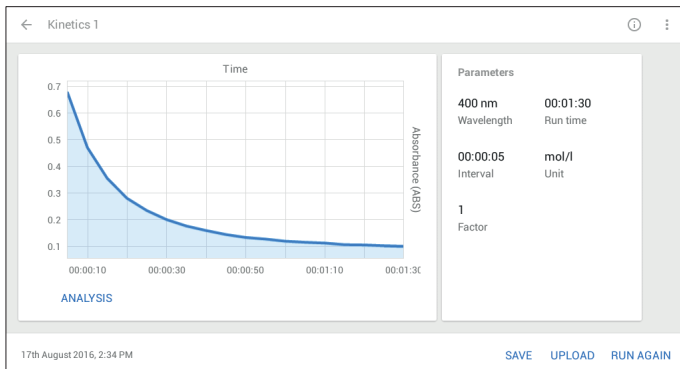

Touch **RUN AGAIN** to touch subsequent samples in the same way.

If any of the parameters are adjusted between sample measurements you will need to perform another blank measurement before more samples can be measured.

## 11.4 Data Analysis

Following the completion of the kinetics measurements it is possible to analyse the data. These include the rate of change and end point concentration. To analyse the data touch **ANALYSIS**.

The rate of change of absorbance over time can be viewed for the entire kinetics run or for selected parts of the kinetics run. Touch  on the graph and slide to the required start or end point in the kinetics run. The rate of change will automatically update. If the end point is moved, this will automatically update the end point concentration.

Alternatively touching   will move the start or end point lines to the required time.

Touch  to return to the results screen.

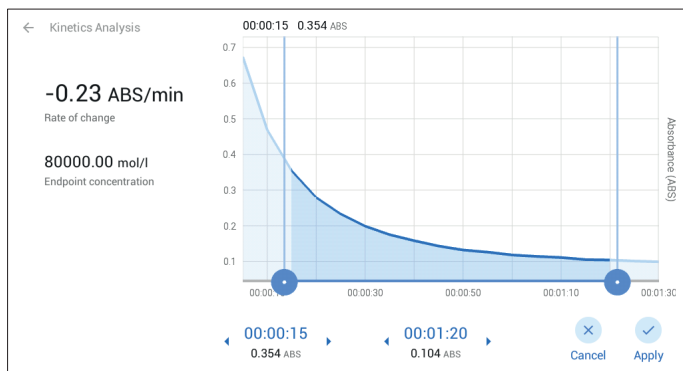

## Section 12 - Multi-Wavelength

The multi-wavelength measurement mode enables measurements of absorbance and % transmittance to be performed, as well as concentration and ratios to be calculated. The sample can be measured at four different wavelengths and at one point in time. Touch the Multi-wavelength icon on the main menu to enter this measurement mode.

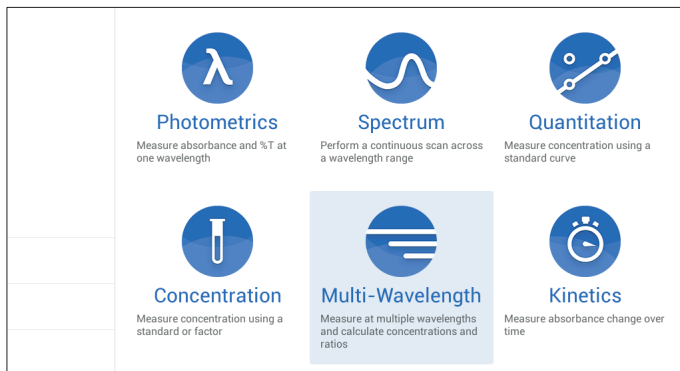

### 12.1 Method Set up

The parameters which can be entered in this measurement mode are wavelength, type of equation, factor, measurement mode and units of concentration. Once all the required parameters have been entered a calibration can be performed.

#### 12.1.1 Selecting a Wavelength

The wavelength value can be adjusted by touching <sup>Wavelength 1 ( $\lambda_1$ )</sup> **400 nm** and then using the keypad to enter the required wavelength. Touch **Done** to apply the entered wavelength and return to the method set up. Two wavelengths are displayed as the default condition. Touch **+ ADD WAVELENGTH** to add an additional wavelength (up to 4). To remove a wavelength touch **× REMOVE** underneath the wavelength value.

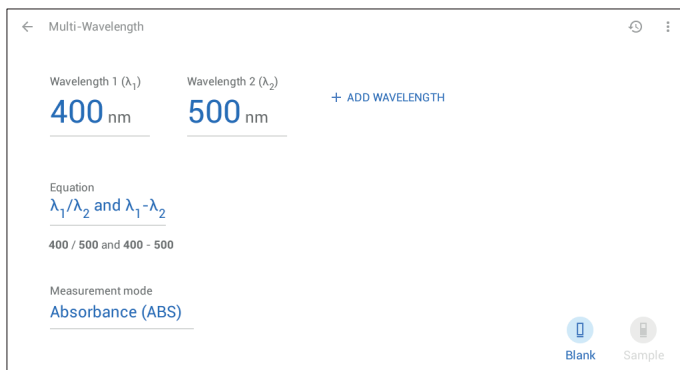

## 12.1.2 Equation Parameters



To select the required equation parameters, touch the <sup>Equation</sup>  $\lambda_1/\lambda_2$  and  $\lambda_1-\lambda_2$ .

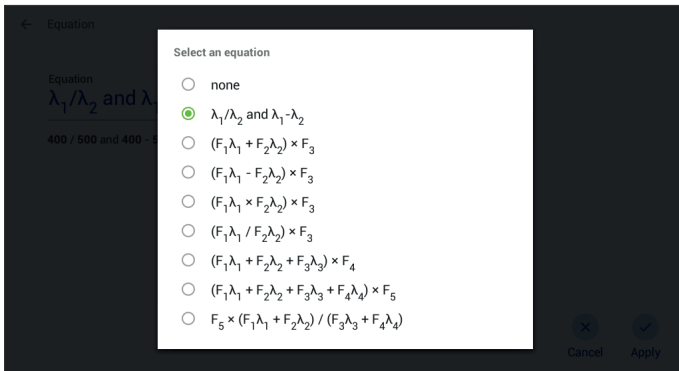

The type of equation can be selected from several options. Touch <sup>Equation</sup>  $\lambda_1/\lambda_2$  and  $\lambda_1-\lambda_2$  and select the required equation from the menu.



If no equation is selected then the factor and units options will be disabled.

Touch  to apply the equation parameters or touch  to return to the method set up without saving any changes.

### 12.1.2.1 Entering a Factor

If the equation selected requires Factors to calculate the concentration result, the factors will also need to be entered.

Touch <sup>Factor F<sub>1</sub></sup> 1.000 and use the keypad to enter the required factor. Touch **Done** to apply the entered factor.

Touch  to apply the factor or touch  to return to the method set up without saving any changes.

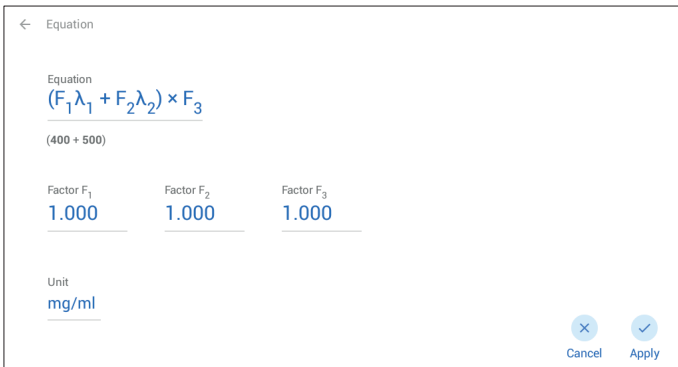

The screenshot shows a screen titled "Equation" with a back arrow. The equation  $(F_1 \lambda_1 + F_2 \lambda_2) \times F_3$  is displayed, with the value  $(400 + 500)$  entered below it. Below the equation, there are three input fields for factors: Factor F<sub>1</sub> (1.000), Factor F<sub>2</sub> (1.000), and Factor F<sub>3</sub> (1.000). At the bottom, the unit is set to "mg/ml". There are "Cancel" and "Apply" buttons at the bottom right.

### 12.1.2.2 Selecting Concentration Units

If the result from the selected equation is a concentration then the units of concentration will also need to be selected. The units of concentration can be selected from several options. Touch <sup>Unit</sup> mg/ml to select from the menu.

Touch the circle  adjacent to the required unit of concentration. The selected unit will be displayed against the final concentration result.

Touch  to apply the concentration units or touch  to return to the method set up without saving any changes.

### 12.1.3 Selecting Absorbance or % Transmittance

The default operating mode is absorbance. To change this between absorbance or % transmittance, touch

<sup>Measurement mode</sup> Absorbance (ABS) or <sup>Measurement mode</sup> Transmittance (% T) to select the required measurement mode. Repeat touches will cycle between the two options.



## 12.2 Blank Measurement

A blank measurement must be performed at the same wavelengths at which the sample will be measured. Open the spectrophotometer lid and pipette the blank solution onto the lower read head and close the lid. Touch

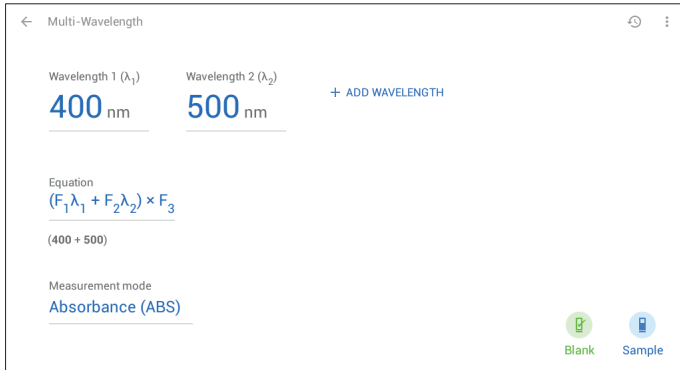
 and the instrument will calibrate to zero absorbance and 100% transmittance.



## 12.3 Sample Measurement

Once a blank measurement has been performed  will become active and a sample can be measured. Remove the blank solution by cleaning the upper and lower read heads. Pipette the sample to be analysed onto the lower read and close the lid. Touch  to begin measurement.

Once the measurement is completed the result will be shown on the screen.

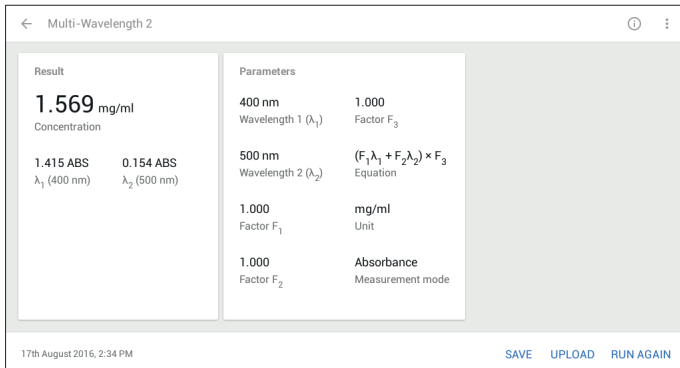

Touch **RUN AGAIN** to measure subsequent samples in the same way.

If any of the parameters are adjusted between sample measurements you will need to perform another blank measurement before more samples can be measured.

## Section 13 - Nucleic Acid Modes

There are three Nucleic Acid modes to choose from on the home screen.



Cole-Parmer recommends that users select the required path length before the start of each experiment. See Section 5 - Micro Volume Settings for more information.

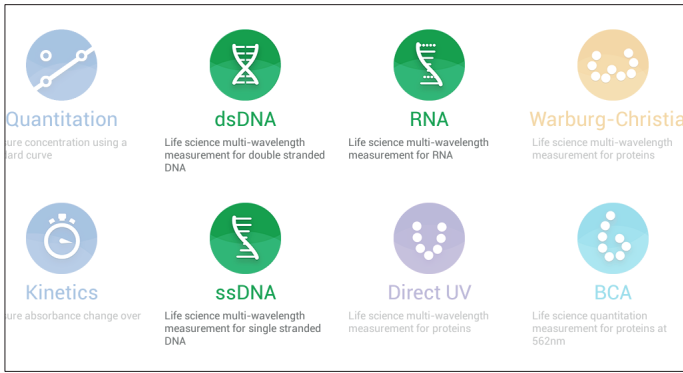

### 13.1 dsDNA



dsDNA

Based on Multi-Wavelength mode. Measures at 260nm ( $\lambda_1$ ) and 280nm ( $\lambda_2$ ) with the option of a correction wavelength at 320nm ( $\lambda_3$ ). There is also the option to include a dilution factor ( $D_f$ ) by inputting sample volume and diluent volume.

Calculation:  $dsDNA (\mu g/ml) = 50 \times \lambda_1 / D_f$   
or  
 $dsDNA (\mu g/ml) = 50 \times (\lambda_1 - \lambda_3) / D_f$

### 13.2 ssDNA



ssDNA

Based on Multi-Wavelength mode. Measures at 260nm ( $\lambda_1$ ) and 280nm ( $\lambda_2$ ) with the option of a correction wavelength at 320nm ( $\lambda_3$ ). There is also the option to include a dilution factor ( $D_f$ ) by inputting sample volume and diluent volume.

Calculation:  $ssDNA (\mu g/ml) = 33 \times \lambda_1 / D_f$   
or  
 $ssDNA (\mu g/ml) = 33 \times (\lambda_1 - \lambda_3) / D_f$

### 13.3 RNA



RNA

Based on Multi-Wavelength mode. Measures at 260nm ( $\lambda_1$ ) and 280nm ( $\lambda_2$ ) with the option of a Correction wavelength at 320nm ( $\lambda_3$ ). There is also the option to include a dilution factor ( $D_f$ ) by inputting sample volume and diluent volume.

Calculation:  $RNA (\mu g/ml) = 40 \times \lambda_1 / D_f$   
or  
 $RNA (\mu g/ml) = 40 \times (\lambda_1 - \lambda_3) / D_f$



Each of the nucleic acid modes is set up and performed in the same way. For the purpose of the instructions, dsDNA has been used as reference only.

## 13.4 Method Set up

The parameters which can be entered in this measurement mode are wavelength, type of equation\*, dilution volume, sample volume.

\*If you choose the dsDNA with correction for protein contamination equation, you can enter factors if required. See 8.4.2 Equation Parameters for more information.

### 13.4.1 Selecting a Wavelength

The wavelength value can be adjusted by touching <sup>Wavelength 1 ( $\lambda_1$ )</sup> **260 nm** or <sup>Wavelength 2 ( $\lambda_2$ )</sup> **280 nm** and then using the keypad to enter the required wavelength.

To add background correction touch **+ ADD BACKGROUND CORRECTION AT 320NM**, to remove touch **X REMOVE**

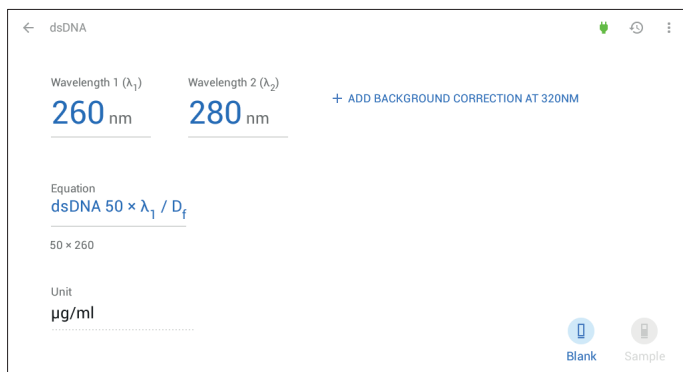

### 13.4.2 Equation Parameters

The equation you choose will determine which parameters you can change. See table below for details of parameters that can be changed.

Equation	Dilution Volume	Sample Volume	Factor <sub>1</sub>	Factor <sub>2</sub>
<b>dsDNA 50 x <math>\lambda_1</math> / <math>D_f</math></b> dsDNA	✓	✓	✗	✗
<b>ssDNA 33 x <math>\lambda_1</math> / <math>D_f</math></b> ssDNA	✓	✓	✗	✗
<b>RNA 40 x <math>\lambda_1</math> / <math>D_f</math></b> RNA	✓	✓	✗	✗
<b>(<math>F_1</math> x <math>\lambda_1</math> - <math>F_2</math> x <math>\lambda_2</math>) / <math>D_f</math></b> dsDNA with correction for protein contamination	✓	✓	✓	✓
<b><math>\lambda_1</math> / <math>\lambda_2</math></b> purity ratio	✓	✓	✗	✗
<b>dsDNA 50 x <math>\lambda_1</math> / <math>D_f</math> and <math>\lambda_1</math> / <math>\lambda_2</math></b> dsDNA and purity ratio	✓	✓	✗	✗

The equation parameters can be adjusted. From the method set up screen touch <sup>Equation</sup>  $dsDNA\ 50 \times \lambda_1 / D_f$ . To change the equation touch <sup>Equation</sup>  $dsDNA\ 50 \times \lambda_1 / D_f$ .

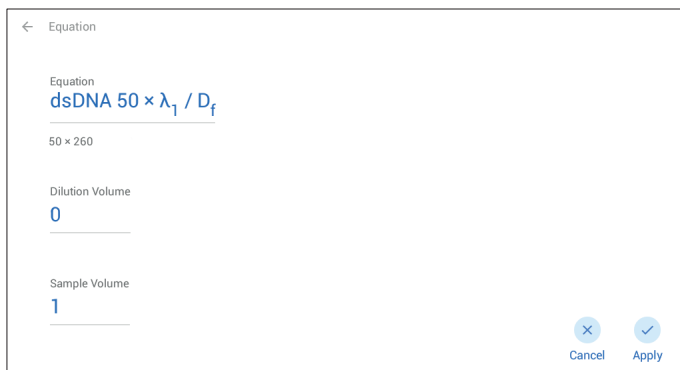

Select the required equation from the menu.

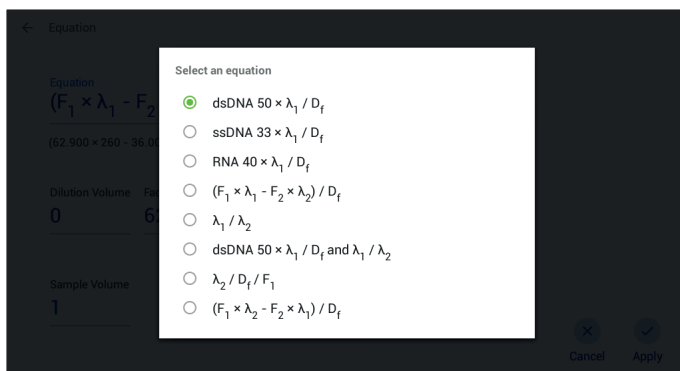

### 13.4.2.1 Entering a Dilution Volume / and Sample Volume

If the equation requires dilution volume and sample volume, they will need to be entered. Touch <sup>Dilution Volume</sup> 0 or <sup>Sample Volume</sup> 1 and use the keypad to enter the required values. Touch **Done** to confirm.

### 13.4.2.2 Entering a Factor

If the equation requires factors, they will need to be entered. Touch <sup>Factor F<sub>1</sub></sup> 62.900 or <sup>Factor F<sub>2</sub></sup> 36.000 and use the keypad to enter the required values. Touch **Done** to confirm.

Once you have chosen the equation and equation parameters touch <sup>Apply</sup> to apply the factor or touch <sup>Cancel</sup> to return to the method set up without saving any changes.

### 13.5 Blank Measurement



A blank measurement must be performed at the same wavelengths at which the sample will be measured. Open the spectrophotometer lid and pipette the blank solution onto the lower read head and close the lid. Touch

 and the instrument will calibrate to zero absorbance and 100% transmittance.

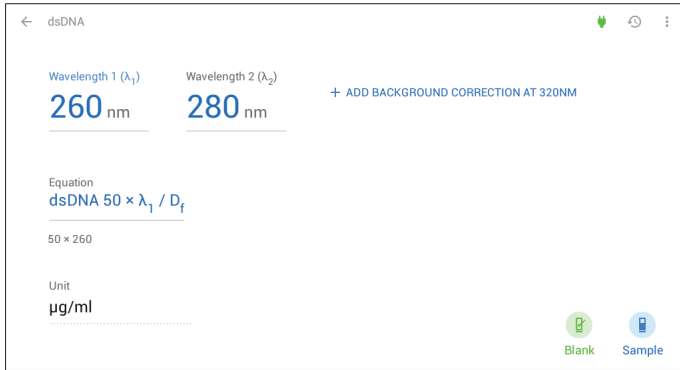
Blank



### 13.6 Sample Measurement

Once a blank measurement has been performed  will become active and a sample can be measured. Remove the blank solution by cleaning the upper and lower read heads. Pipette the sample to be analysed onto the lower read and close the lid. Touch  to begin measurement.

Sample

Once the measurement is completed the result will be shown on the screen.

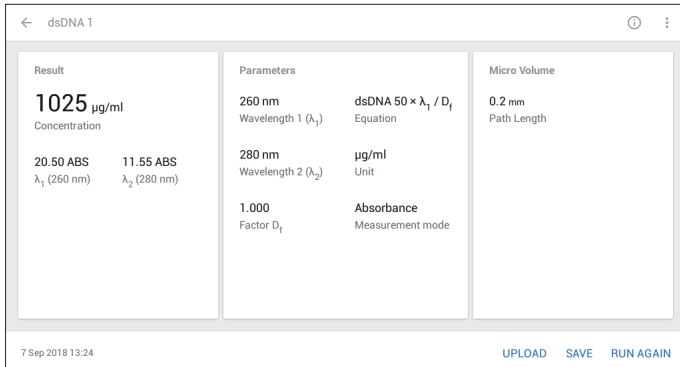

Touch **RUN AGAIN** to measure subsequent samples in the same way.

If any of the parameters are adjusted between sample measurements you will need to perform another blank measurement before more samples can be measured.

## Section 14 - Protein Modes

There are two Protein modes to choose from on the home screen.

 Cole-Parmer recommends that users select the required path length before the start of each experiment. See Section 5 - Micro Volume Settings for more information.

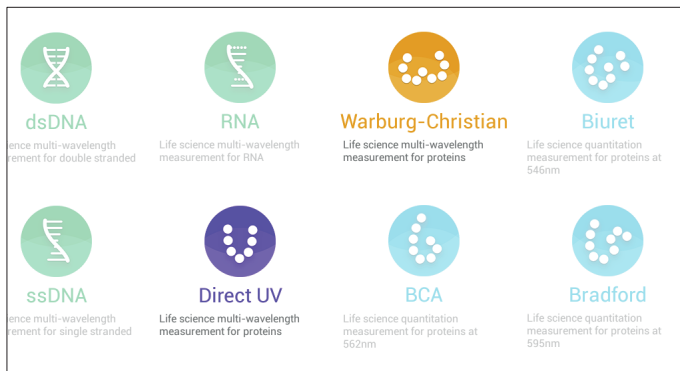

### 14.1 Direct UV



Based on Multi-Wavelength mode. Measures at 260nm ( $\lambda_1$ ) and 280nm ( $\lambda_2$ ) with the option of a correction wavelength at 320nm ( $\lambda_3$ ). There is also the option to include a dilution factor ( $D_f$ ) by inputting sample volume and diluent volume.

Calculation: Protein (mg/ml) =  $(\lambda_2 / D_f) / F_1$   
 or  
 Protein (mg/ml) =  $((\lambda_2 - \lambda_3) / D_f) / F_1$

$F_1$  is a factor that can be used to input extinction coefficients etc.

### 14.2 Warburg-Christian



Based on Multi-Wavelength mode. Measures at 260nm ( $\lambda_1$ ) and 280nm ( $\lambda_2$ ) with the option of a correction wavelength at 320nm ( $\lambda_3$ ). There is also the option to include a dilution factor ( $D_f$ ) by inputting sample volume and diluent volume.

Calculation: Protein (mg/ml) =  $(F_1 \times \lambda_2 - F_2 \times \lambda_1) / D_f$   
 or  
 Protein (mg/ml) =  $(F_1 \times (\lambda_2 - \lambda_3) - F_2 \times (\lambda_1 - \lambda_3)) / D_f$

$F_1 = 1.550$  and  $F_2 = 0.760$

 Each of the protein modes is set up and performed in the same way. For the purpose of the instructions, Direct UV has been used as reference only.

## 14.3 Method Set up

The parameters which can be entered in this measurement mode are wavelength, dilution volume, sample volume.

### 14.3.1 Selecting a Wavelength

The wavelength value can be adjusted by touching <sup>Wavelength 1 ( $\lambda_1$ )</sup> 260 nm or <sup>Wavelength 2 ( $\lambda_2$ )</sup> 280 nm and then using the keypad to enter the required wavelength.

To add background correction touch + ADD BACKGROUND CORRECTION AT 320NM, to remove touch X REMOVE

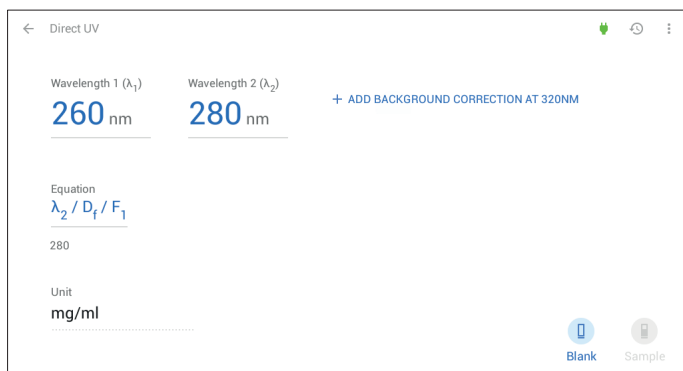

### 14.3.2 Equation Parameters

The equation parameters can be adjusted. From the method screen touch <sup>Equation</sup>  $\lambda_2 / D_f / F_1$ .

#### 14.3.2.1 Entering a Dilution Volume and Sample Volume

If the equation requires dilution volume and sample volume, they will need to be entered. Touch <sup>Dilution Volume</sup> 0 or <sup>Sample Volume</sup> 1 and use the keypad to enter the required values. Touch Done to confirm.

#### 14.3.2.2 Entering a Factor

If the equation requires factors, they will need to be entered. Touch <sup>Factor F₁</sup> 1.000 and use the keypad to enter the required values. Touch Done to confirm.

Once you have chosen the equation and equation parameters touch  Apply to apply the factor or touch  Cancel to return to the method set up without saving any changes.

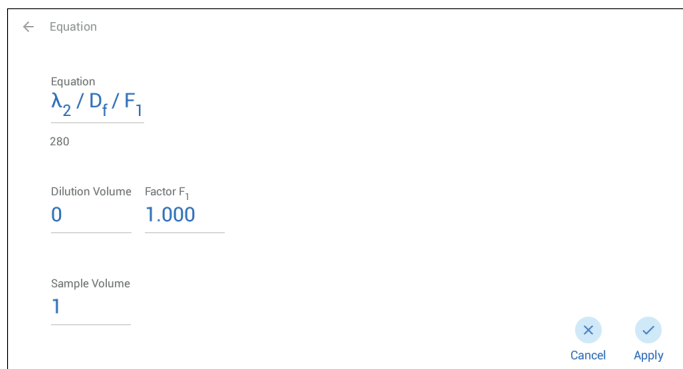

## 14.4 Blank Measurement



A blank measurement must be performed at the same wavelengths at which the sample will be measured. Open the spectrophotometer lid and pipette the blank solution onto the lower read head and close the lid. Touch

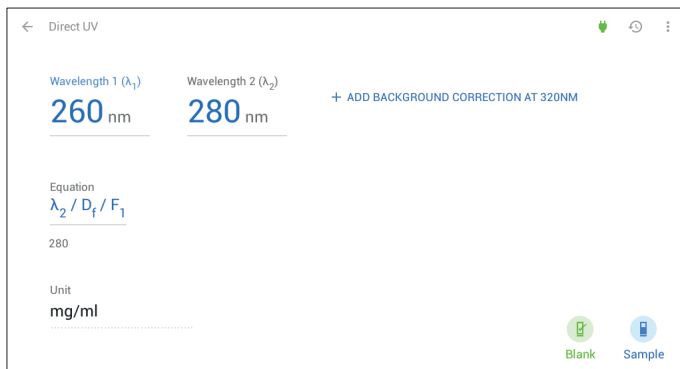

and the instrument will calibrate to zero absorbance and 100% transmittance.



## 14.5 Sample Measurement

Once a blank measurement has been performed  will become active and a sample can be measured. Remove the blank solution by cleaning the upper and lower read heads. Pipette the sample to be analysed onto the lower read and close the lid. Touch  to begin measurement.

Once the measurement is completed the result will be shown on the screen.

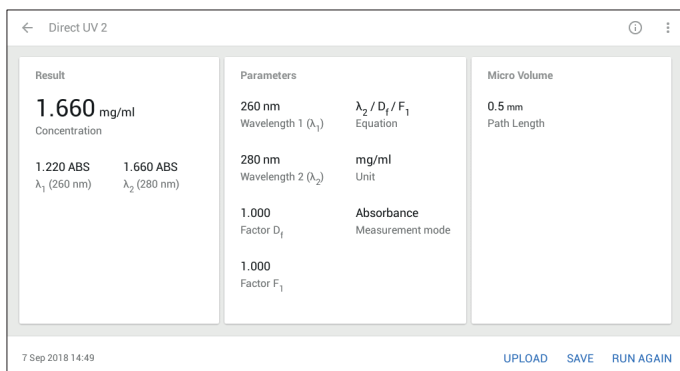

Touch **RUN AGAIN** to measure subsequent samples in the same way.

If any of the parameters are adjusted between sample measurements you will need to perform another blank measurement before more samples can be measured.

## Section 15 - Colorimetric Protein Assays

There are five Colorimetric Protein Assays modes to choose from on the home screen.



Cole-Parmer recommends that users select the required path length before the start of each experiment. See Section 5 - Micro Volume Settings for more information.

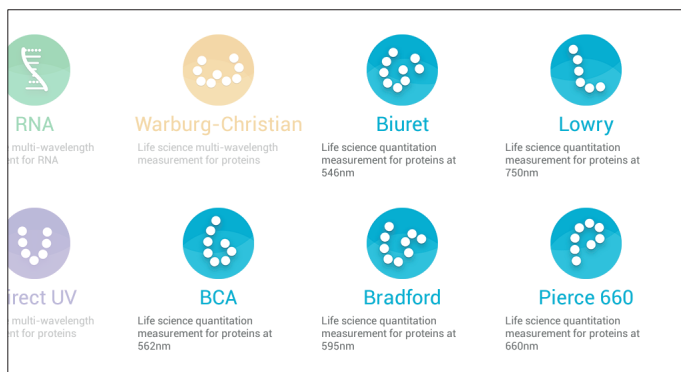

All of the five colorimetric protein assays modes are based on the Quantitation mode and differ only in the wavelength they use. They all have an option of a background correction wavelength if required by the protocol. See below for settings.

### 15.1 BCA



Life Science quantitation measurement for proteins at 562nm

Measurement Wavelength 562nm  
Background Wavelength 750nm

### 15.2 Biuret



Life Science quantitation measurement for proteins at 546nm

Measurement Wavelength 546nm  
Background Wavelength 750nm

### 15.3 Bradford



Life Science quantitation measurement for proteins at 595nm

Measurement Wavelength 595nm  
Background Wavelength 750nm

### 15.4 Lowry



Life Science quantitation measurement for proteins at 750nm

Measurement Wavelength 750nm  
Background Wavelength 405nm

### 15.5 Pierce 660



Life Science quantitation measurement for proteins at 660nm

Measurement Wavelength 660nm  
Background Wavelength 770nm



Each of the colorimetric protein assays modes is set up and performed in the same way. For the purpose of the instructions, Pierce 660 has been used as reference only.

## 15.6 Method Set up

The parameters which can be entered in this measurement mode are wavelength, number of replicates for the calibration standards and concentration units for the calibration standards.

### 15.6.1 Selecting a Wavelength

The wavelength value can be adjusted by touching <sup>Wavelength</sup> **660 nm** and using the keypad to enter the required wavelength. The wavelength needs to be the same for both the measurements of the standards and the unknown sample.

To add background correction touch **+ ADD BACKGROUND CORRECTION**, to remove touch **X REMOVE**

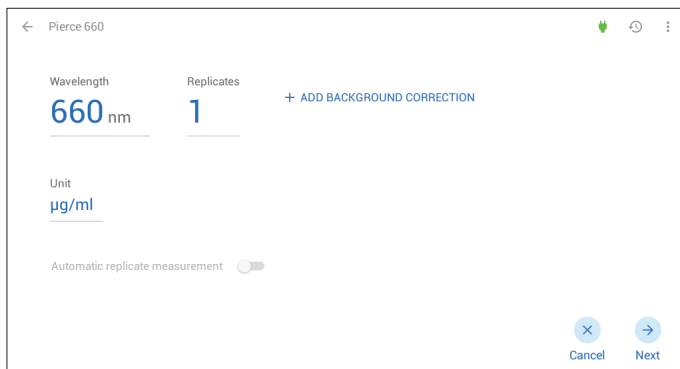

### 15.6.2 Selecting Number of Replicates

To select the number of repeat measurements of a calibration standard touch <sup>Replicates</sup> **1**. Touch the circle adjacent to the required unit of replicates to apply and return to the method set up.

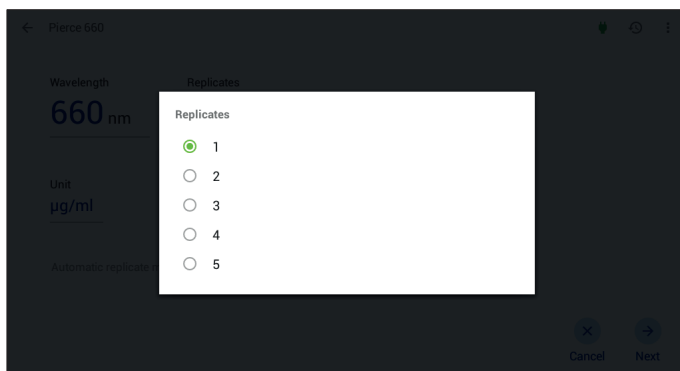



If 2 or more replicates are selected, **Automatic replicate measurement**  becomes active. Automatic replicates will read the same sample for the selected number of replicates. If individual sample replicates are being used, do not select the automatic replicates option.

### 15.6.3 Selecting Concentration Units

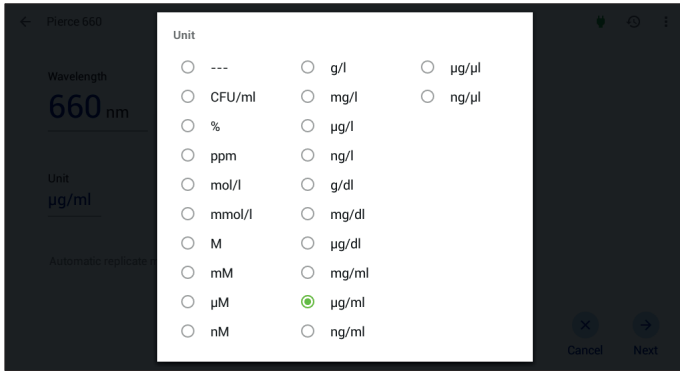
The units of concentration can be selected from several options. Touch <sup>Unit</sup>  $\mu\text{g/ml}$  to select from the menu. Touch the circle adjacent to the required unit of concentration. The selected unit will be displayed against the final concentration result.



Once the method parameters have been entered touch  to start measuring the calibration standards. Touch  to return to the home screen.

### 15.7 Measuring Calibration Standards

The measured standards are used to create a calibration curve. Touch **+ ADD STANDARD** to add the 1st standard.

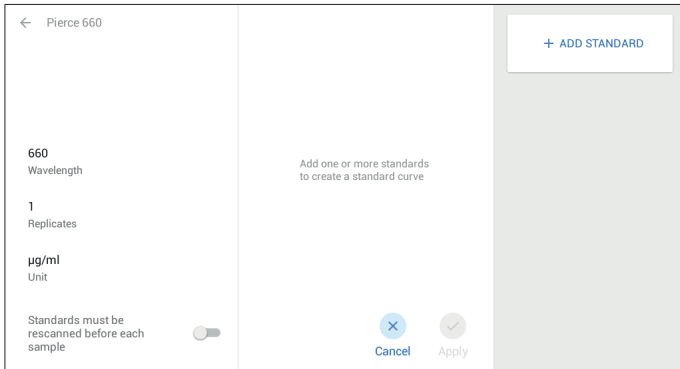

Touch **100**  $\mu\text{g/ml}$  and use the keypad to enter the concentration value required for that standard. Touch **Done** to confirm.

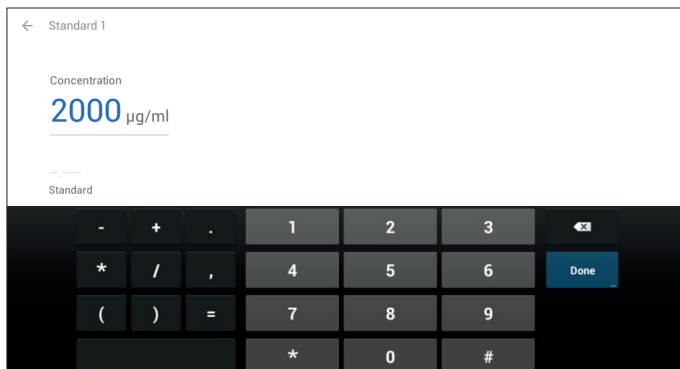

Before the 1st standard can be measured you will need to perform a blank measurement. Open the spectrophotometer lid and pipette the blank solution onto the lower read head and close the lid. Touch **Blank** and the instrument will calibrate to zero absorbance and 100% transmittance.

Once the blank measurement is complete **Standard** will become active, remove the blank solution by cleaning the upper and lower read heads and then pipette the 1st known standard solution onto the lower read head and close the lid. Touch **Sample** to measure the standard.

If there are 2 or more replicates, measure the 1st replicate and then replace it with the next replicate and measure. Repeat this process until all replicates have been measured.

If using **Automatic replicate measurement** , the same standard will be read for the selected number of times.

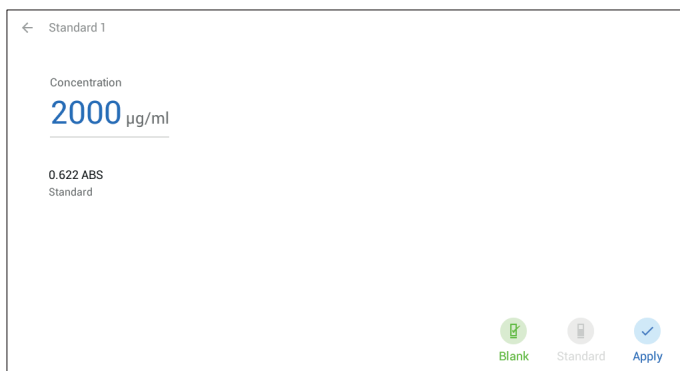

Touch **Apply** to save the absorbance result for the 1st standard.

Touch **+ ADD STANDARD** to add another standard and use the keypad to enter the concentration value required. This time a blank measurement is not required so **Standard** is active straight away. Pipette the 2nd known standard solution onto the lower read head and close the lid. Touch **Standard** to measure the standard.

If there are 2 or more replicates, measure the 1st replicate and then replace it with the next replicate and measure. Repeat this process until all replicates have been measured.

If using **Automatic replicate measurement**, the same standard will be read for the selected number of times.

Touch **Apply** to save the absorbance result for the 2nd standard.

Repeat the process for the number of standards required to create the calibration curve.

A calibration curve can be set up in advance and concentrations saved for future use without measuring the absorbance values. When Pierce 660 is next performed, each standard is read to calculate the standard curve. To activate this, slide **Standards must be rescanned before each sample** to on. This can aid in the preparation of when Pierce 660 is frequently used.

## 15.8 Standard Curve

Following the measurement of each standard the calibration curve is displayed.

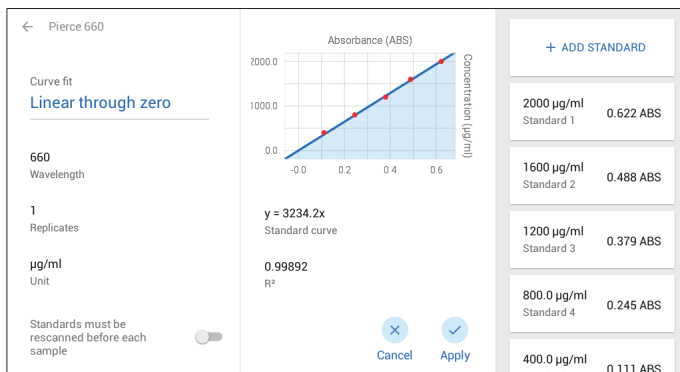

Specific points can be selected on the graph by touching the graph, a sliding cursor will appear. It is possible to move the cursor by dragging left or right.

The curve fit algorithm can be changed by touching **Curve fit Linear through zero**. Select between Linear through zero, Linear, Quadratic through zero and quadratic.

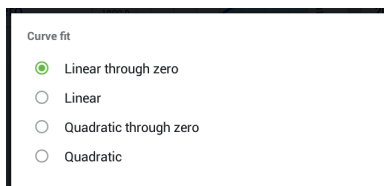

The curve statistics are also displayed for the curve fit chosen. For example if curve fit is  $y = mx + c$  the curve statistics displayed will be the gradient of the line ( $m$ ), constant ( $c$ ) and correlation coefficient ( $R_2$ ).

Once all the standards have been measured touch apply and then the unknown samples can be measured.

## 15.9 Sample Measurement

Ensure the upper and lower read heads are clean and pipette the sample to be measured onto the lower read head, close the lid and touch  .

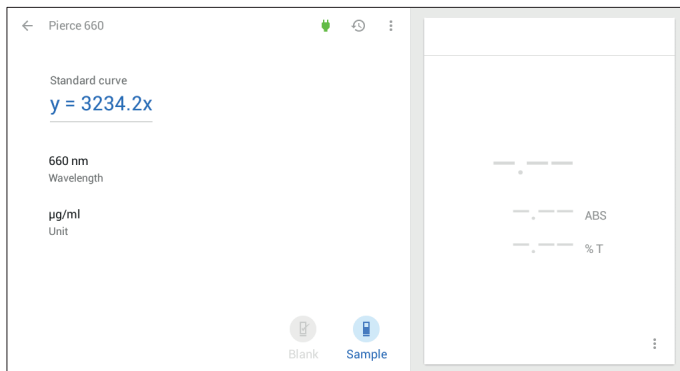

Once the measurement is complete the results will be shown on the screen.

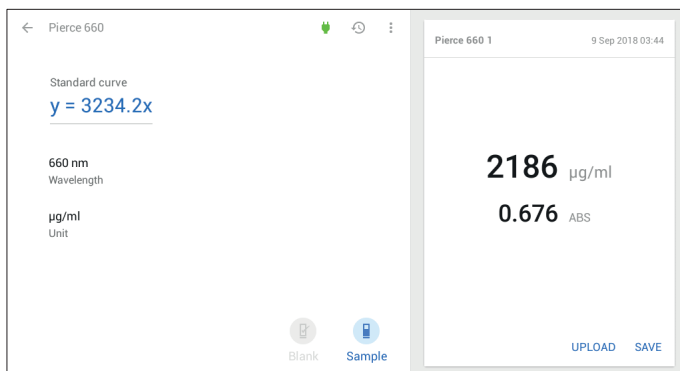

Touch  to measure subsequent samples in the same way.

If any of the parameters are adjusted between sample measurements you will need to perform another blank measurement and a new standard curve must be created before more samples can be measured.



To change the curve fit at any time touch <sup>Standard curve</sup>   $y = 3234.2x$  to return to the standard curve screen.

## Section 16 - Saving, Loading, Deleting and Printing

### 16.1 Saving Methods





#### 16.1.1 Saving Methods to Internal Memory

On each method set up screen there is an overflow icon .

Touch  and then touch  Save as Method to save the entered method parameters. Use the keypad to enter the method name and touch  Save to apply the name, touch [SAVE](#).

#### 16.1.2 Saving Methods to USB Memory Stick

You can save your methods to USB memory stick via the home or method set up screen.

On the home screen touch  Methods. Touch , you can then select each method individually by touching  by the side of each method or touch  to select all the methods. Touch the overflow icon  and then touch  Export to USB Drive.

On the method set up screen touch  and then touch  Export to USB Drive to save the entered method parameters.

### 16.2 Loading Methods





#### 16.2.1 Loading Methods from Internal Memory

On the home screen touch  Methods. Select the required method from the list and touch [RUN](#) to open.

#### 16.2.2 Loading Methods from USB Memory Stick

This option is currently unavailable.

### 16.3 Deleting Methods





On the home screen touch  Methods. Touch , you can then select each method individually by touching  by the side of each method or touch  to select all the methods. To delete, touch  this will then give you the option to [CANCEL](#) or [DELETE](#).

## 16.4 Saving Results

### 16.4.1 Saving Results to Internal Memory

After a measurement has been performed, touch **SAVE**.

### 16.4.3 Saving Results to USB Memory Stick

On the home screen touch  Results. Touch , you can then select each method individually by touching  by the side of each method or touch  to select all the methods. Touch the overflow icon  and then touch  Export to USB Drive.

## 16.5 Loading Results





### 16.5.1 Loading Results from Internal Memory

On the home screen touch  Results. Touch the required result from the list to view information.

### 16.5.2 Loading Results from USB Memory Stick

This option is currently unavailable.

## 16.6 Deleting Results

On the home screen touch  Results. Touch , you can then select each result individually by touching  by the side of each result or touch  to select all the results. To delete, touch  this will then give you the option to **CANCEL** or **DELETE**.

## 16.7 Printing

Results can be printed by connecting the optional printer SMP50/PRINTER to one of the type A USB ports on the front of the spectrophotometer, see 2.3 Overview. Following completion of a result, the option to print will be displayed. Touch **PRINT** to print the results.

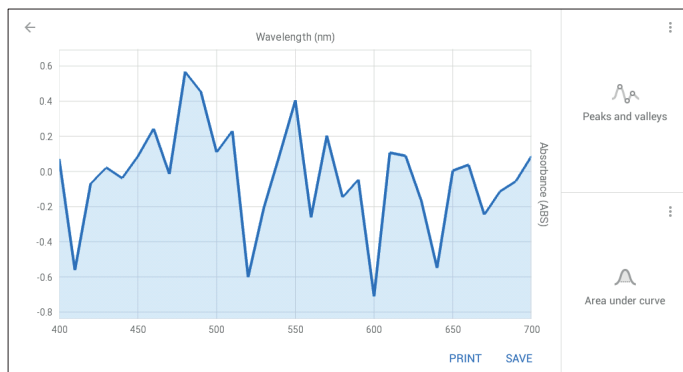

Results shown as an example only.

## Section 17 - Accessories and Spare Parts

### 17.1 Optional Accessories

Please visit [www.Cole-Parmer.com](http://www.Cole-Parmer.com) for a full list of available accessories.

### 17.2 Spare Parts

Please contact your local sales specialist or email [cpspars@coleparmer](mailto:cpspars@coleparmer) to enquire about available spares.

## Section 18 - Maintenance and Servicing



**WARNING:** Before attempting any maintenance, servicing or cleaning, ensure that the equipment has been allowed to cool down.



**WARNING:** Ensure the equipment is disconnected from the power supply before attempting any maintenance, servicing or cleaning.



**WARNING:** Do not work within the equipment while the lamp is ON as exposure to the high intensity light can cause injury to your eyes.

### 18.1 Routine Maintenance

#### 18.1.1 Cleaning

Ensure the external surfaces of the unit are clean and free from dust. The sample area should always be kept clean and any accidental spillage should be wiped away immediately. To give added protection when not in use, the equipment should be disconnected from the mains supply.

If the equipment needs to be cleaned ensure the equipment is switched off and disconnected from the mains supply before cleaning. Wipe down the unit with a soft damp cloth and a mild detergent solution. Do not use bleach or abrasives. Do not allow cleaning liquids to ingress inside the equipment. Never immerse the unit, cables or plugs in water or any other liquids. Allow any wet surfaces to dry before re-connecting to the mains supply and commencing use.



**WARNING:** This product does not contain bio-seals as per EN 61010-1-2010 and cannot provide any level of containment in case of a spill or release of toxic, radioactive, or pathogenic micro-organisms thus these materials are not recommended to be used in this product.

**NOTE:** Do not use solvents for cleaning any parts of this equipment.

#### 18.1.2 Read Head Cleaning

Wiping the sample from both the upper and lower read heads upon completion of each sample measurement with a lint free cloth is usually sufficient to prevent sample carryover and avoid residue build-up. Although generally not necessary, water aliquots can be used to clean the measurement surfaces after the measurement of particularly highly concentrated samples to ensure no residual sample is retained on either read head. After measuring a large number of samples, it is recommended that the areas around the upper and lower read heads are cleaned thoroughly. This will prevent spread of contamination from previous samples which could affect subsequent low-level measurements. A final cleaning of all surfaces with deionised water is also recommended

after the last measurement.

### 18.1.3 Read Head Re-conditioning

Reagents containing surfactants can “un-condition” the measurement read head surfaces so that the liquid does not form a stable sample droplet. If this occurs, “buff” the read head surfaces by rubbing each measurement surface firmly with a dry laboratory wipe 30-40 times. This will “re-condition” the surface allowing the sample droplet to form.

### 18.1.4 In Case of Accidental Spillage



**WARNING:** Do not touch if a spillage/breakage has occurred. Disconnect the power directly at the power supply source.

If any part of the unit has been exposed to liquid, it cannot be assumed to meet all the safety requirements of EN 61010-1-2010 until the drying out process has been fully completed and all safety requirements are met before the unit is used again.

### 18.1.5 In Case of Contamination



**WARNING:** The following procedure is intended as a guide. Should spillage of a toxic or hazardous fluid occur, then additional special precautions may be necessary.

If the equipment has been exposed to contamination, the Responsible Body is responsible for carrying out appropriate decontamination. If hazardous material has been spilt on or inside the equipment, decontamination should only be undertaken under the control of the Responsible Body with due recognition of possible hazards. Before using any cleaning or decontamination method, the Responsible Body should check with the manufacturer that the proposed method will not damage the equipment. Prior to further use, the Responsible Body shall check the electrical safety of the unit. Only if all safety requirements are met can the unit be used again.

A sanitising solution, such as a 0.5% solution of sodium hypochlorite (1:10 dilution of common commercial bleach - freshly prepared), can be used to ensure that no biologically active material is present on the measurement read heads. The read head fittings are made from stainless steel and are resistant to most common laboratory solvents. See Section 24 - Chemical Compatibility for more information.

**NOTE:** In the event of this equipment or any part of the unit becoming damaged or requiring service, the item(s) should be returned to the manufacturer for repair accompanied by a decontamination certificate. Copies of the Certificate are available from the Distributor/Manufacturer.

At the end of its service life, the product must be accompanied by a Decontamination Certificate.

## **18.2 Service, Repairs and Support**

Any service, repairs or replacement of parts MUST be undertaken by suitably qualified personnel. Only spare parts supplied or specified by Cole-Parmer or its agents should be used. Fitting of non-approved parts may affect the performance and safety features designed into the instrument. For a comprehensive list of parts required by service engineers conducting internal repairs please contact the service department quoting the model and serial number:

Email: [cpSERVICE@coleparmer.com](mailto:cpSERVICE@coleparmer.com)

Tel: +44 (0)1785 810475

For technical support enquiries please contact;

Email: [cpTECHSUPPORT@coleparmer.com](mailto:cpTECHSUPPORT@coleparmer.com)

Tel: +44 (0)1785 810433

### **18.2.1 Xenon Lamp Module Replacement**

This must only be done by an accredited service engineer, see Section 18.3 - Warranty for more information.

## **18.3 Warranty**

Cole-Parmer Ltd. warrants this instrument to be free from defects in material and workmanship, when used under normal laboratory conditions, for a period of 3 years. This includes the Xenon lamp used in the SP-500-NANO. In the event of a justified claim Cole-Parmer will replace any defective component or replace the unit free of charge. This warranty does NOT apply if damage is caused by fire, accident, misuse, neglect, incorrect adjustment or repair, damage caused by incorrect installation, adaptation, modification, fitting of non-approved parts or repair by unauthorised personnel.

Cole-Parmer Ltd,

Beacon Road,

Stone,

Staffordshire,

ST15 0SA,

United Kingdom

Email: [cpSERVICE@coleparmer.com](mailto:cpSERVICE@coleparmer.com)

Tel: +44 (0)1785 810475

Web: [www.Cole-Parmer.com](http://www.Cole-Parmer.com)

## **Section 19 - Environmental Protection**

### **19.1 Packaging Material**



Packaging materials have been carefully selected so they can be sorted for recycling.

### **19.2 Waste Electrical and Electronic Equipment Directive (WEEE)**



At the end of your product and accessories life, it must not be discarded as domestic waste. Ref: EU Directive 2012/19/EU on Waste Electrical and Electronic Equipment Directive (WEEE). Please

contact your distributor / supplier for further information. For end users outside of the EU consult applicable regulations.

## Section 20 - Calibration

Cole-Parmer recommend that the micro volume accessory is calibrated every 6 months. A set of calibration solutions is available to order (part code 035 092). Please note that the calibration solutions should be discarded 1 week after being opened.

When using the calibration solutions we advise the use of chemically resistant gloves and goggles and there is eye wash available immediately. We recommend safe handling of the calibration solution - avoid skin contact, direct inhalation or ingestion of the standards as advised in the M.S.D.S.

### 20.1 Calibration Solutions

The supplied calibration solution set consists of 2 vials:

- 1 Matrix Blank (white label)

10x ref - Calibration Standard (blue label)

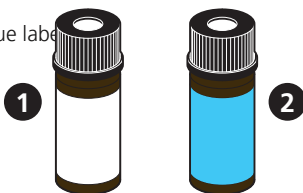

A certificate of validation is supplied that details the certified absorbance values of the calibration standard and the path length at which these values were determined. Use the corrected values provided for plinth-based systems.

### 20.2 Calibration Procedure

The micro volume icon is displayed on the home screen and at the top of the screen in each measurement mode.

Touch  to access

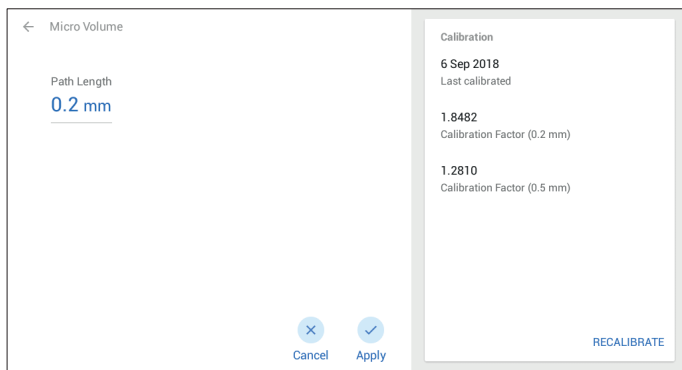

The details of the last calibration are shown. Touch **RECALIBRATE** to start recalibration.

Enter the value

t. Touch  **Start**

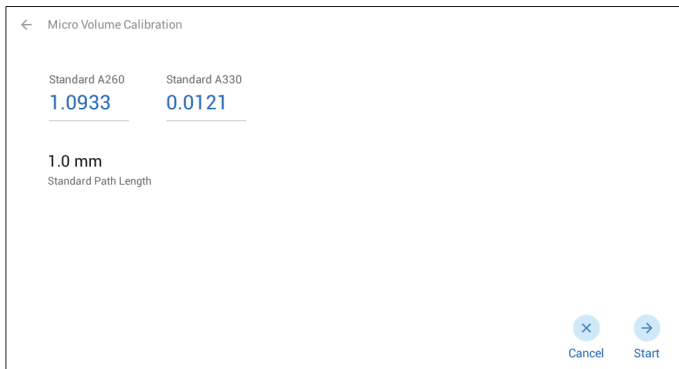

## 20.2.1 Step 1 - Air

Touch , wh

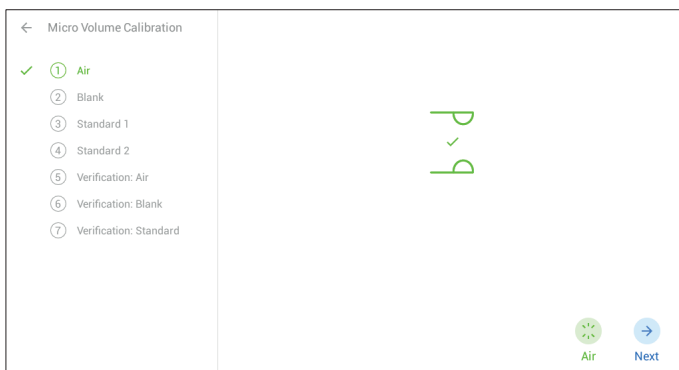



## 20.2.2 Step 2 - Blank

Pipette matrix blank solution (white label) onto the lower read head, close the lid and touch . When the instrument fini

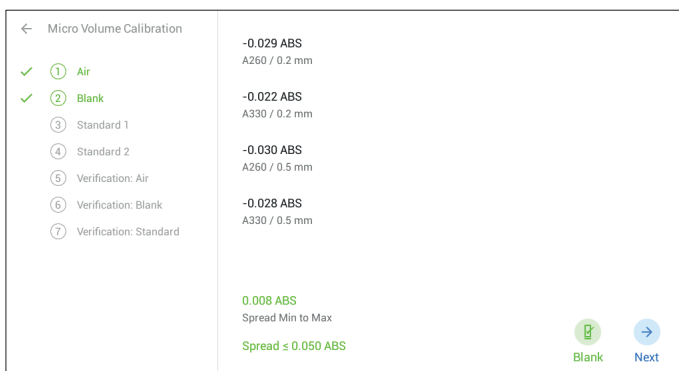
ext calibration step.



### 20.2.3 Step 3 - Standard 1

Pipette 10x ref calibration standard (blue label) onto the lower read head, close the lid and touch  . When the instrument finishes, clean the upper and lower read heads and touch  to move onto the next calibration step.

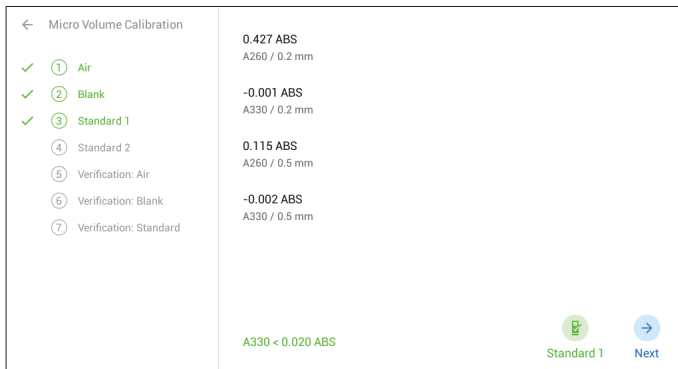

Micro Volume Calibration



- ✓ ① Air
- ✓ ② Blank
- ✓ ③ Standard 1
- ④ Standard 2
- ⑤ Verification: Air
- ⑥ Verification: Blank
- ⑦ Verification: Standard

<b>0.427 ABS</b> A260 / 0.2 mm	
<b>-0.001 ABS</b> A330 / 0.2 mm	
<b>0.115 ABS</b> A260 / 0.5 mm	
<b>-0.002 ABS</b> A330 / 0.5 mm	

A330 < 0.020 ABS

Standard 1 Next

### 20.2.4 Step 4 - Standard 2

Pipette 10x ref calibration standard (blue label) onto the lower read head, close the lid and touch  . When the instrument finishes, clean the upper and lower read heads and touch  to move onto the next calibration step.

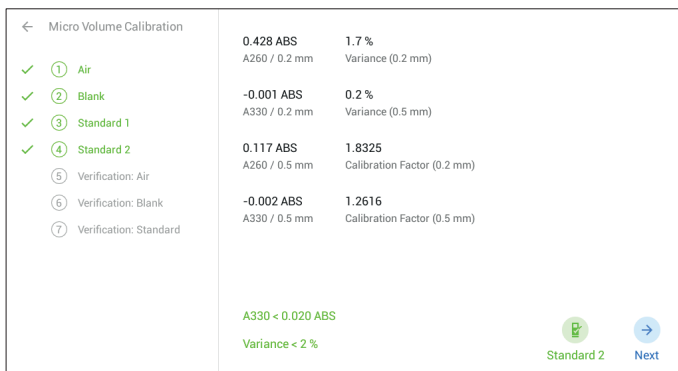

Micro Volume Calibration



- ✓ ① Air
- ✓ ② Blank
- ✓ ③ Standard 1
- ✓ ④ Standard 2
- ⑤ Verification: Air
- ⑥ Verification: Blank
- ⑦ Verification: Standard

<b>0.428 ABS</b> A260 / 0.2 mm	<b>1.7 %</b> Variance (0.2 mm)
<b>-0.001 ABS</b> A330 / 0.2 mm	<b>0.2 %</b> Variance (0.5 mm)
<b>0.117 ABS</b> A260 / 0.5 mm	<b>1.8325</b> Calibration Factor (0.2 mm)
<b>-0.002 ABS</b> A330 / 0.5 mm	<b>1.2616</b> Calibration Factor (0.5 mm)

A330 < 0.020 ABS  
Variance < 2 %

Standard 2 Next

### 20.2.5 Step 5 - Verification: Air

Touch  , when the instrument finishes touch  to move onto the next calibration step.

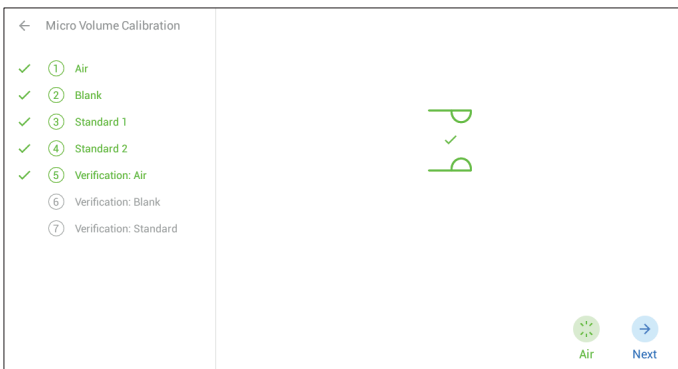



Micro Volume Calibration

- ✓ ① Air
- ✓ ② Blank
- ✓ ③ Standard 1
- ✓ ④ Standard 2
- ✓ ⑤ Verification: Air
- ⑥ Verification: Blank
- ⑦ Verification: Standard

P  
✓  
P

Air Next

## 20.2.6 Step 6 - Verification: Blank

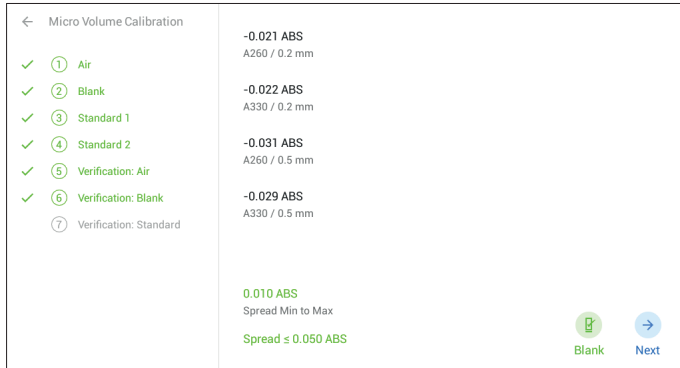

Pipette matrix blank solution (white label) onto the lower read head, close the lid and touch . When the instrument finishes, clean the upper and lower read heads and touch  to move onto the next calibration step.





Micro Volume Calibration

✓ ① Air	-0.021 ABS A260 / 0.2 mm
✓ ② Blank	-0.022 ABS A330 / 0.2 mm
✓ ③ Standard 1	
✓ ④ Standard 2	-0.031 ABS A260 / 0.5 mm
✓ ⑤ Verification: Air	
✓ ⑥ Verification: Blank	-0.029 ABS A330 / 0.5 mm
⑦ Verification: Standard	

0.010 ABS  
Spread Min to Max  
Spread  $\leq$  0.050 ABS

## 20.2.7 Step 7 - Verification: Standard



Pipette 10x ref calibration standard (blue label) onto the lower read head, close the lid and touch . When the instrument finishes, clean the upper and lower read heads and touch  to finish the calibration process.

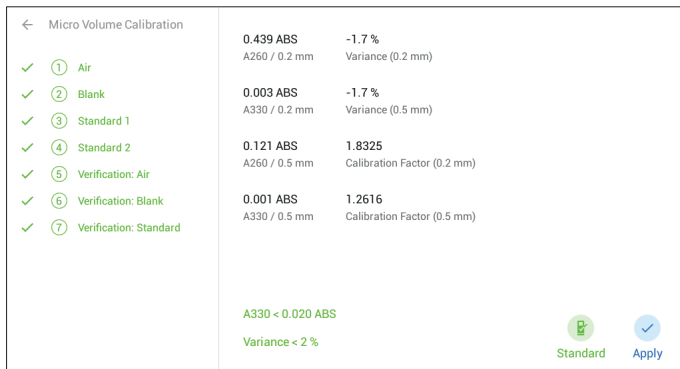

Micro Volume Calibration

✓ ① Air	0.439 ABS A260 / 0.2 mm	-1.7 % Variance (0.2 mm)
✓ ② Blank	0.003 ABS A330 / 0.2 mm	-1.7 % Variance (0.5 mm)
✓ ③ Standard 1		
✓ ④ Standard 2	0.121 ABS A260 / 0.5 mm	1.8325 Calibration Factor (0.2 mm)
✓ ⑤ Verification: Air		
✓ ⑥ Verification: Blank	0.001 ABS A330 / 0.5 mm	1.2616 Calibration Factor (0.5 mm)
✓ ⑦ Verification: Standard		

A330 < 0.020 ABS  
Variance < 2 %

The recalibration is now complete and details of the latest calibration are shown.



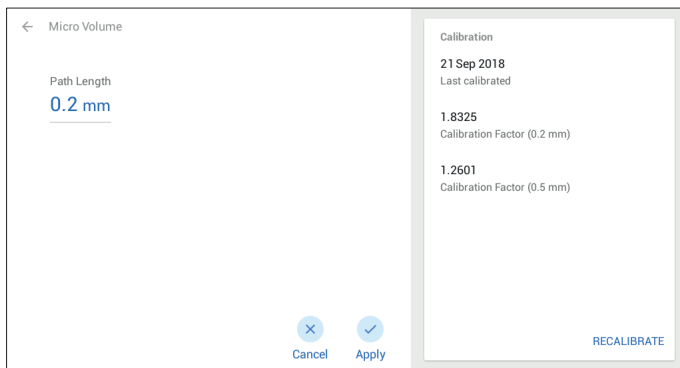

Micro Volume

Path Length  
**0.2 mm**

Calibration  
**21 Sep 2018**  
Last calibrated

1.8325  
Calibration Factor (0.2 mm)

1.2601  
Calibration Factor (0.5 mm)

RECALIBRATE

## Section 21 - Technical Specification

### 21.1 General Specification

	<b>SP-500-NANO</b>
Wavelength Range	198 to 1000nm
Resolution	1.0nm
Wavelength Accuracy	± 2.0nm
Spectral Bandwidth	5.0nm
Path Length	0.2 or 0.5mm (user-selected)
Absorbance Range	- 15 to 125A (10mm equivalent)
Absorbance Accuracy	± 2% at 260nm
Absorbance Precision	<0.005A (between 0.000A and 1.000A) 2% (between 1.000 and 2.000A) 5% (above 2.000A)
Maximum Concentration	6000ng/µl (dsDNA) (at 0.2mm)
Detection Limit	5.0ng/µl (dsDNA) (at 0.5mm)
Concentration reproducibility	+/-2.5ng/µl for dsDNA samples ≤= 100ng/µl
Measurement Time	< 6.5 seconds
Minimum sample Size	0.5µl (at 0.2mm), 1.0µl (at 0.5mm)
Maximum sample size	5.0µl
Nucleic acid measurement modes	dsDNA, ssDNA, RNA, 260/280
Protein measurement modes	BCA, Biuret, Bradford, Lowry, Pierce 660, Direct UV, Warburg-Christian
Spectrophotometric modes	Photometrics, Concentration, Quantitation, Kinetics, Spectrum
Sample Pedestal Material	Quartz stainless steel
Light Source	Press to read Xenon lamp
Internal memory	10GB for results and methods
Outputs	USB Type A x2, USB Type B x1, Ethernet connection (RJ45)
Power supply unit	24 V d.c. 2.5 A
Size (w x d x h)	280 x 500 x 156mm
Weight	9.0kg
Warranty	3 years (including Xenon lamp)

## 21.2 Weights and Dimensions

Weight 9.0kg

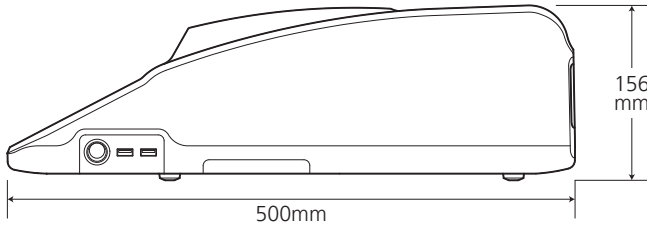
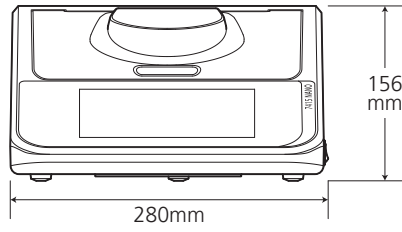

## Section 22 - Troubleshooting

### During initial power on self-test (POST)

The following errors can appear during the initial self-test.

A hardware problem has been detected. You may continue to use the instrument but calibration data may have been affected causing any readings to be inaccurate. Contact Cole-Parmer support and quote error code 101.

A hardware problem has been detected. Contact Cole-Parmer support and quote error code 102.

A potential hardware problem has been detected. If the lid is currently open, close it and try again. If it's currently closed, contact Cole-Parmer support and quote error code 103.

A hardware problem has been detected. Contact Cole-Parmer support and quote error code 104.

A hardware problem has been detected. Contact Cole-Parmer support and quote error code 105.

A hardware problem has been detected. Contact Cole-Parmer support and quote error code 106.

A hardware problem has been detected. Contact Cole-Parmer support and quote error code 107.

A potential hardware problem has been detected. If there's currently a sample in the instrument, remove it and try again. If there's no sample in the instrument, contact Cole-Parmer support and quote error code 108.

A potential hardware problem has been detected. If there's currently a sample in the instrument, remove it and try again. If there's no sample in the instrument, contact Cole-Parmer support and quote error code 109.

A potential hardware problem has been detected with the fitted micro volume accessory. Contact Cole-Parmer support and quote error code 110.

A potential hardware problem has been detected with the fitted cell changer accessory. Contact Cole-Parmer support and quote error code 111.

## **During scanning (blank, standard or sample)**

The following errors can appear whenever the optical hardware is used. Each error message will be attached to the activity which was just performed.

The error messages are displayed as a notification on screen with an option to display more information about the error. If multiple errors have been detected, they will be displayed in the more information.

### **The '*blank / standard / sample*' failed due to a potential hardware fault**

A fault has been found whilst taking the reading. If an accessory is connected, check the cable is firmly connected and turn the instrument on and off again before trying again. If this continues to occur contact Cole-Parmer support and quote error message 112.

### **The '*blank / standard / sample*' failed due to a potential hardware fault**

A fault has been found whilst taking the reading. If an accessory is connected, check the cable is firmly connected and turn the instrument on and off again before trying again. If this continues to occur contact Cole-Parmer support and quote error message 113.

### **The '*blank / standard / sample*' failed because the lamp has been disabled due to being too warm**

The instrument has disabled the lamp because the unit is too warm. Check the air vents for any obstructions which may be interrupting airflow, and turn the unit off to allow it to cool down. If this continues to occur contact Cole-Parmer support and quote error message 114.

### **The '*blank / standard / sample*' failed because a potential hardware fault detected with the fan**

The fan has dropped below its normal operating speed. Check the air vents for any obstructions which may be interrupting airflow, and then turn the instrument off and on again before trying again. If this continues to occur contact Cole-Parmer support and quote error message 115.

### **The '*blank / standard / sample*' failed due to potential hardware fault**

Turn the instrument on and off again and try again. If this continues to occur, contact Cole-Parmer support and quote error message 116.

### **The '*blank / standard / sample*' failed because the lamp is too hot**

Check the air vents for any obstructions which may be interrupting airflow and turn the unit off to allow it to cool down. If this continues to occur, contact Cole-Parmer support and quote error message 117.

The following warning messages will be displayed next to results when detected. They are indicated by an icon, which when pushed will display a dialogue containing the warning information.















































### **Lamp warm up warning**

The lamp is still warming up. This can take up to 30 minutes after turning the instrument on, or after entering lamp safe mode. Readings taken during this time may be inaccurate.

### **Calibration data lost warning**

This reading may be inaccurate as a hardware problem has affected calibration data.

## Section 23 - Glossary of Icons

	Sample warning		Lowry		Overflow
	Analysis Area under curve		Pierce		Accessory attached
	Analysis Peaks and valleys		Back arrow		Printer
	Concentration		Blank		Take reading
	Kinetics		Blank complete		Save
	Multi-wavelength		Apply		Search
	Photometrics		Select files		Settings
	Quantitation		Cancel		Spectrum peak
	Spectrum		Unused turret position		Spectrum valley
	dsDNA		Delete		Standard complete
	RNA		Select all		Stop
	ssDNA		Deselect favourite		Results
	Direct UV		Favourite		Export to USB
	Warburg-Christian		Load method		Hide favourites panel
	BCA		Save as method		Network connections
	Biuret		Measurement Settings		Service settings
	Bradford		Clear recent		
			Information		

## Section 24 - Chemical Compatibility

Assay	Chemical	Concentration
BCA	Sodium bicinchoninate	1%*
BCA	Sodium carbonate	2%*
BCA	Sodium tartrate	0.16%*
BCA	Sodium hydroxide	0.1M*
BCA	Sodium bicarbonate	0.95%*
BCA	Copper (II) sulphate	0.08%
Biuret	Sodium potassium tartrate	0.9%*
Biuret	Copper (II) sulphate	0.3%*
Biuret	Potassium iodide	0.5%*
Biuret	Sodium hydroxide	0.08M
Lowry	Sodium carbonate	1.6%
Lowry	Copper (II) sulphate	0.032%
Lowry	Sodium potassium tartrate	0.016%
Lowry	Sodium dodecyl sulphate	0.08%
Lowry	Sodium hydroxide	0.08M
Lowry	Folin reagent (lithium and sodium molybdotungstophosphate solution)	0.04N*
Bradford	Coomassie brilliant Blue G-250	0.01%*
Bradford	Ethanol	4.75%*
Bradford	Phosphoric acid	8.5%*
Bradford	Sodium hydroxide	0.1M
	DMSO	10%
	Acetonitrile	OK
	Methanol	OK
	2-Propanol	OK

\*Highest concentration

# Index

## A

Accessories and Spare Parts .....	63
Adding a Sample .....	22
Adding, Removing and Recovering Samples .....	22

## B

BCA .....	55
Biuret .....	55
Bradford .....	55

## C

Calibration .....	66
Calibration Procedure .....	66
Step 1 - Air .....	67
Step 2 - Blank .....	67
Step 3 - Standard 1 .....	68
Step 4 - Standard 2 .....	68
Step 5 - Verification: Air .....	68
Step 6 - Verification: Blank .....	69
Step 7 - Verification: Standard .....	69
Calibration Solutions .....	66
Chemical Compatability .....	75
Cleaning .....	63
Colorimetric Protein Assays .....	55
BCA .....	55
Biuret .....	55
Bradford .....	55
Lowry .....	55
Pierce 660 .....	55

Concentration .....	25
Blank Measurement .....	26
Calibrating to a Factor .....	27
Calibrating to a Standard .....	27
Measuring a Sample After Calibrating to a Factor .....	28
Measuring a Sample After Calibrating to a Standard .....	28
Method Set up .....	25
Sample Measurement .....	28
Selecting a Wavelength .....	25
Selecting Concentration Units .....	26
Using a Factor .....	25
Using a Standard .....	26

## D

Deleting Methods .....	61
Deleting Results .....	62
Direct UV .....	52
Blank Measurement .....	54
Entering a Dilution Volume and Sample Volume .....	53
Entering a Factor .....	53
Equation Parameters .....	53
Method Set up .....	53
Sample Measurement .....	54
Selecting a Wavelength .....	53
dsDNA .....	48
Blank Measurement .....	51
Entering a Dilution Volume and Sample Volume .....	50
Entering a Factor .....	50
Equation Parameters .....	49
Method Set up .....	49
Sample Measurement .....	51
Selecting a Wavelength .....	49

## E

Electrical Requirements .....	8
Environmental Protection .....	65

## G

General Description .....	7
General Specification .....	70
Glossary of Icons .....	74
Good Practice Guidelines .....	13

## I

Important Safety Advice .....	7
In Case of Accidental Spillage .....	64
In Case of Contamination .....	64
Index .....	76
Installation .....	9
Installation Conditions .....	9
Instrument Set up .....	14
Introduction .....	7

<b>K</b>		
Kinetics .....	39	
Blank Measurement .....	41	
Data Analysis .....	43	
End Point Concentration .....	40	
Method Set up .....	39	
Sample Measurement .....	41	
Selecting Absorbance or % Transmittance .....	40	
Selecting a Wavelength .....	39	
Setting Lag Time .....	40	
Setting the Kinetics Measurement Time .....	40	
Setting the Measurement Time Interval .....	40	
<b>L</b>		
Loading Methods .....	61	
Loading Methods from Internal Memory .....	61	
Loading Methods from USB Memory Stick .....	61	
Loading Results .....	62	
Loading Results from Internal Memory .....	62	
Loading Results from USB Memory Stick .....	62	
Lowry .....	55	
<b>M</b>		
Maintenance and Servicing .....	63	
Main View .....	10	
Methods .....	15	
Micro Volume Settings .....	21	
Multi-Wavelength .....	44	
Blank Measurement .....	47	
Entering a Factor .....	46	
Equation Parameters .....	45	
Method Set up .....	44	
Sample Measurement .....	47	
Selecting Absorbance or % Transmittance .....	46	
Selecting a Wavelength .....	44	
Selecting Concentration Units .....	46	
<b>N</b>		
Navigation .....	14	
Nucleic Acid Modes .....	48	
dsDNA .....	48	
RNA .....	48	
ssDNA .....	48	
<b>O</b>		
Optional Accessories .....	63	
Overview .....	10	
<b>P</b>		
Packaging Material .....	65	
Photometrics .....	23	
Blank Measurement .....	24	
Method Set up .....	23	
Sample Measurement .....	24	
Selecting a Wavelength .....	23	
Pierce 660 .....	55	
Measuring Calibration Standards .....	57	
Method Set up .....	56	
Sample Measurement .....	60	
Selecting a Wavelength .....	56	
Selecting Concentration Units .....	57	
Selecting Number of Replicates .....	56	
Standard Curve .....	59	
Printing .....	62	
Protein Modes .....	52	
Direct UV .....	52	
Warburg-Christian .....	52	
<b>Q</b>		
Quantitation .....	34	
Measuring Calibration Standards .....	36	
Method Set up .....	34	
Sample Measurement .....	38	
Selecting a Wavelength .....	34	
Selecting Concentration Units .....	35	
Selecting Number of Replicates .....	35	
Standard Curve .....	37	
<b>R</b>		
Read Head Cleaning .....	63	
Read Head Re-conditioning .....	64	
Rear View .....	10	
Recovering a Sample .....	22	
Removing a Sample .....	22	
Results .....	16	
RNA .....	48	
Routine Maintenance .....	63	

**S**

Saving, Loading, Deleting and Printing .....	61
Saving Methods .....	61
Saving Methods to Internal Memory.....	61
Saving Methods to USB Memory Stick .....	61
Saving Results .....	62
Saving Results to Internal Memory.....	62
Saving Results to USB Memory Stick .....	62
Service, Repairs and Support .....	65
Settings .....	16
Instrument Status.....	16
Measurement Settings.....	16
Network Connections .....	17
Regional Settings .....	18
Instrument Language .....	20
Setting the Date .....	19
Setting the Time.....	18
Setting the Time Zone .....	19
Service Settings .....	20
Storage .....	17
Spare Parts.....	63
Spectroscopy Measurement .....	12
Spectrum .....	29
Area Under Curve .....	32
Area Under Curve - Baseline Mode.....	32
Area Under Curve - Tangent Mode.....	33
Blank Measurement .....	30
Data Analysis .....	31
Method Set up.....	29
Peaks and Valleys .....	31
Sample Measurement.....	30
Selecting Absorbance or % Transmittance .....	30
Setting Start and End Wavelengths.....	29
Setting the Scan Interval.....	30
ssDNA.....	48
Start up Screen .....	14
Symbols Defined .....	7

**T**

Technical Specification .....	70
-------------------------------	----

Theory and Practice of Spectroscopy Measurement .....	11
Theory of Spectroscopy Measurement.....	11
Troubleshooting .....	72
During initial power on self-test (POST).....	72
During scanning (blank, standard or sample) .....	73

**U**

Unpacking .....	9
-----------------	---

**W**

Warburg-Christian .....	52
Warranty.....	65
Waste Electrical and Electronic Equipment Directive (WEEE) ..	65
Weights and Dimensions.....	71

**X**

Xenon Lamp Module Replacement.....	65
------------------------------------	----

# Declaration of Conformity



This product meets the applicable CE Directives and UKCA Legislation for radio frequency interference and may be expected not to interfere with, or be affected by, other equipment with similar qualifications. We cannot be sure that other equipment used in its vicinity will meet these standards and so we cannot guarantee

that interference will not occur in practise. Where there is a possibility that injury, damage or loss might occur if equipment malfunctions due to radio frequency interference, or for general advise before use, contact the manufacturer.

Declaration of Conformity is available to view online at [www.coleparmer.com](http://www.coleparmer.com)

#### **EU Representative address**

Cole-Parmer Ltd  
Bâtiment le Deltaparc Icade  
Paris Nord 2  
7 rue du Canal  
BP 55437 Villepinte  
95944 ROISSY Charles de Gaulle  
France  
Tel: +33 (0) 1 48 63 78 00  
Email: [frsales@antylia.com](mailto:frsales@antylia.com)

#### **UK Representative address**

Antylia Scientific  
9 Orion Court  
Ambuscade Road  
Colmworth Business Park  
St. Neots  
PE19 8YX  
United Kingdom

# Ordering Information

Order No.	Cole-Parmer Series	Cole-Parmer Model	Jenway Model	Jenway Part No.
83056-23	SP-500	SP-500-NANO	7415 Nano Micro Volume Spectrophotometer	747501

## Warranty Registration



### UK

T: +44 (0) 1480 272279  
E: [uk.sales@antylia.com](mailto:uk.sales@antylia.com)  
W: [coleparmer.co.uk](http://coleparmer.co.uk)

### Germany

T: +49 (0) 9377 92030  
E: [de.sales@antylia.com](mailto:de.sales@antylia.com)  
W: [coleparmer.de](http://coleparmer.de)

### France

T: +33 (0) 1486 37800  
E: [fr.sales@antylia.com](mailto:fr.sales@antylia.com)  
W: [coleparmer.fr](http://coleparmer.fr)

### Italy

T: +39 (0) 284349215  
E: [it.sales@antylia.com](mailto:it.sales@antylia.com)  
W: [coleparmer.com](http://coleparmer.com)

### India

T: +9122 61394444  
E: [info@coleparmer.in](mailto:info@coleparmer.in)  
W: [coleparmer.in](http://coleparmer.in)

### China

T: +1 847 549 7600  
E: [sales@antylia.com](mailto:sales@antylia.com)  
W: [coleparmer.com](http://coleparmer.com)

### USA

T: +1 847 549 7600  
E: [sales@antylia.com](mailto:sales@antylia.com)  
W: [coleparmer.com](http://coleparmer.com)

### Canada

T: +514 355 6100  
E: [info@antylia.ca](mailto:info@antylia.ca)  
W: [coleparmer.ca](http://coleparmer.ca)

### Other

T: +1 847 549 7600

# Cole-Parmer®

**Antylia Scientific Ltd.**  
Beacon Road,  
Stone,  
Staffordshire,  
ST15 0SA,  
United Kingdom

