



**OWNER'S MANUAL
FOR
AIR ADMIRAL® VACUUM/PRESSURE STATION**

MODELS:

79202-00

79202-05

79202-30

79202-35

Approval Agency's

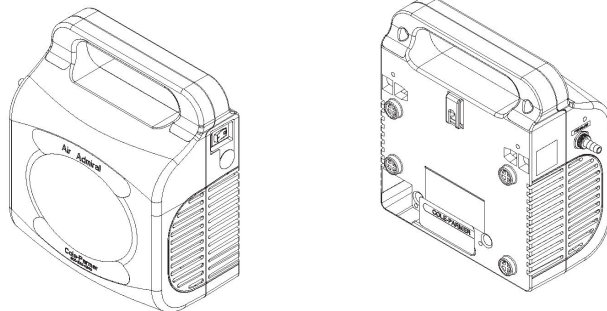

Model 79202-00 & 79202-05

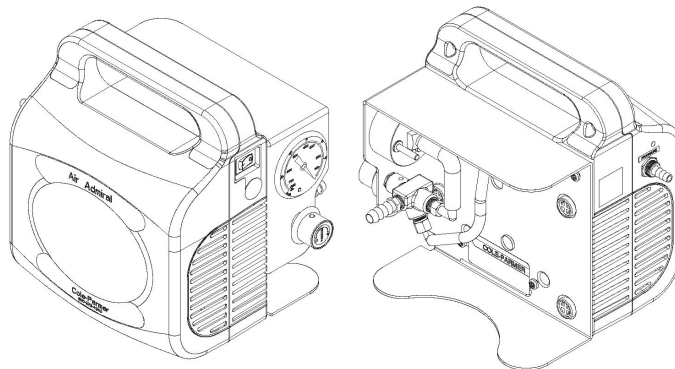

Model 79202-30 & 79202-35



WARNING
**Not recommended for pumping acid,
base or organic vapors or gases.**

Cole-Parmer Instrument Company
625 East Bunker Court
Vernon Hills, IL 60061-1844
Phone: 1-800-323-4340
Fax: 847-247-2929
E-Mail: info@coleparmer.com
Web-Page: www.coleparmer.com

Part No. 67-0889R1.2
Printed in USA

**INSTRUCTION
WARNING AND CAUTION
PLEASE READ BEFORE OPERATION**

While reading your manual, please pay close attention to areas labeled:
WARNING AND CAUTION.
The description of each is found below.

WARNING
Warnings are given where failure to observe instruction could result in injury or death to people.

CAUTION
Cautions are found where failure to observe the instruction could result in damage to the equipment, associated equipment and process.

These units confirm to the SI International system of units of measurement.

The following symbols (with recommendation of IEC1010) of warning will be found on the pump.



Caution - refer to accompanying documents



Caution - risk of electrical shock



Caution - hot surface



Double Insulated



OFF (Power)



ON (Power)

WARNING
Motor includes a self resetting thermal cutout and the pump could restart without actuation under fault condition.

TABLE OF CONTENTS

Section 01 - SAFETY INFORMATION

- 1.10 Caution To Prevent Injury
- 1.20 Caution To Reduce Risk Of Electrical Shock
- 1.30 Warning To Reduce Risk Of Electrocution
- 1.40 Danger To Reduce Risk Of Explosion Or Fire

Section 02 - INSTALLATION

- 2.10 Introduction
- 2.20 Unpacking
- 2.30 Pump Mounting
- 2.40 Pump Location
- 2.50 Intake And Discharge Provision
- 2.60 Electrical Power
- 2.70 Vacuum Connection
- 2.80 Vacuum Gauges

Section 03 - OPERATION

- 3.10 Starting Procedures
- 3.20 Leak Detection
- 3.30 Operating Pressure Range
- 3.40 Shutdown Procedures

Section 04 - MAINTENANCE

- 4.10 Maintenance Procedures

Section 05 - TROUBLESHOOTING

- 5.10 Vacuum Problems
- 5.20 Pressure Problems
- 5.30 Trouble Shooting Guide

Section 06 - SPECIFICATION

- 6.10 Specification Table

Section 07 - WARRANTY

SECTION 1: SAFETY INFORMATION

1.10 CAUTION: TO PREVENT INJURY...

- 1.11 Never operate this product if it has a damaged cord or plug. If it is not working properly, has been dropped, damaged or has fallen into water, please return the product to a Cole-Parmer service center for examination and repair.
- 1.12 Keep the cord away from heated surfaces. All electrical products generate heat. To avoid serious burns never touch unit during or immediately after operation.
- 1.13 Never block any air openings or place it on a soft surface where the openings may be blocked. The air openings are for ventilation of the motor inside the housing. Keep all air openings free of lint, dirt and other foreign objects.
- 1.14 Models of 79202 are thermally protected and can automatically restart when the protector resets. Always disconnect power source before servicing.
- 1.15 Never drop or insert fingers or any other object into any openings.
- 1.16 Do not operate this product where oxygen is being administered.
- 1.17 Wear safety glasses and goggles when operating this product. Never point any air nozzle or air sprayer toward another person or any part of the body.
- 1.18 Use only in well ventilated areas.
- 1.19 Do not use any tools or attachments without first determining maximum air pressure for that tool or attachment. Be sure to properly identify intake and discharge before using pump. See Section 2.50.



WARNING

Do not fill the collection jar above the safe fill level line indicated on the jar.

1.20 CAUTION: TO REDUCE RISK OF ELECTRICAL SHOCK...

- 1.21 Do not disassemble. Disassembly or attempted repairs if accomplished incorrectly can create electrical shock hazard. Refer servicing to qualified service agencies only.

1.30 WARNING: TO REDUCE RISK OF ELECTROCUTION...

- 1.31 Do not use this product in or near area where it can fall or be pulled into water or other liquids.
- 1.32 Do not reach for this product if it has fallen into liquid. Unplug immediately.
- 1.33 Never operate this product outdoors in the rain or in a wet area.

1.40 DANGER: TO REDUCE RISK OF EXPLOSION OR FIRE...

- 1.41 Do not use this pump in or near explosive atmospheres or where aerosol (spray) products are being used.
- 1.42 Do not pump anything other than atmospheric air.
- 1.43 Do not pump combustible liquids or vapors with this product or use in or near an area where flammable or explosive liquids or vapors may exist.
- 1.44 Do not use this product near flames.



WARNING

Failure to observe the above safety precautions could result in severe bodily injury, including death in extreme cases.

SECTION 2: INSTALLATION

2.10 INTRODUCTION

2.11 This manual has been compiled not only for the care and maintenance of the Cole-Parmer Air Admiral® Vacuum/Pressure Station now in your possession, but as a helpful reference and guide to prevent many problems which may occur if used improperly.

2.20 UNPACKING

2.21 Carefully remove the Air Admiral® Vacuum/Pressure Station from the shipping case. Preserve all paperwork for future reference. If damage has occurred from shipment a claim must be filed with the carrier immediately; preserve the shipping carton for inspection by the carrier. If you are required to communicate with your dealer or Cole-Parmer, be sure to include your order numbers for quick identification. Do not return the pump to the factory without first calling for a returned goods number.

2.30 PUMP MOUNTING

2.31 Rubber feet are attached to the pump. Rubber feet are excellent for applications involving a semi-flexible surface such as a bench top; they help to isolate noise and eliminate creeping. All Air Admiral® Vacuum/Pressure Station should be mounted on a horizontal plane.

2.40 PUMP LOCATION

2.41 The Air Admiral® Vacuum/Pressure Station should be located preferably in a clean, dry, and well ventilated area. Please be sure not to block the ventilation holes located on the motor housing. The system should be placed where the surrounding temperature remains between 10°C and 40°C (50°F and 104°F). Always check to insure the location chosen is protected from direct or indirect moisture contact. Cole-Parmer recommends that the pump be installed at the highest point within the system to prevent possible water condensate from entering the pump. The pump should be located as closely to its system in order to utilize it most efficiently.



WARNING

The motor is thermally protected and will automatically restart unexpectedly when the overload device resets. Don't pump flammable or explosive gases or vapors or operate this pump in an atmosphere containing flammable or explosive gases or vapors.

2.50 INTAKE AND DISCHARGE PROVISION

2.51 The vacuum regulator and vacuum dial gauge is attached to the bracket. The vacuum regulator allows the vacuum level to be set between roughly atmospheric pressure and the maximum vacuum allowed for the pump model. The regulator allows discharge pressure to be set between atmospheric and the maximum possible for the pump model. Model 79202 is equipped with a pressure port.
Note: Adjusting the vacuum regulators will affect the performance of the pump.

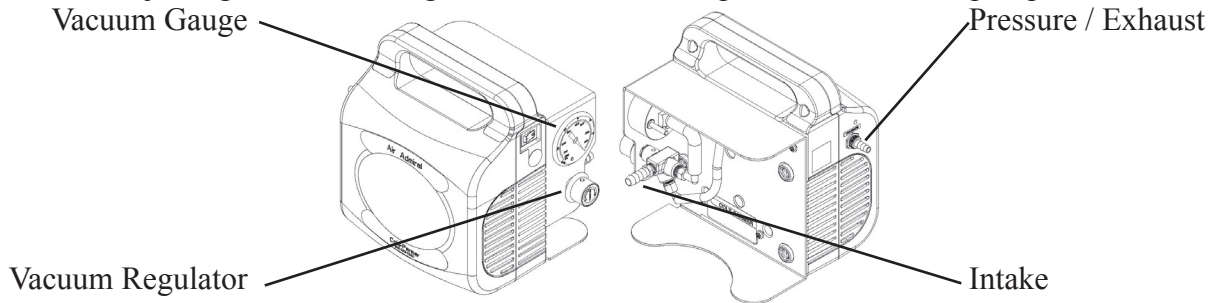

2.60 ELECTRICAL POWER

2.61 Power Source Review

Review the power source and the motor rating to be sure they agree in voltage, phase, and frequency. Serious damage may occur to the motor if it is connected to an improper voltage.

2.62 Servicing of Double-Insulated Product

In a double-insulated product, two systems of insulation are provided instead of grounding. No grounding means is provided on a double-insulated product, nor should a means for grounding to be added to the product. Servicing of a double-insulated product requires extreme care and knowledge of the system and should be done only by qualified service personnel. Replacement parts for the double-insulated product must be identical to those parts in the product.

2.63 Overload Protection

This station has a single use (fuse) type of overload protector. If the motor should overheat, the protector will shut the unit off. If this should occur, unplug the station and contact the service center.

2.64 Classification And Symbol Glossary

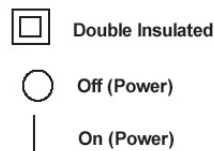

2.70 VACUUM CONNECTIONS

2.71 For best results, Cole-Parmer recommends the length of the tubing between the pump and the chamber be kept as small as possible.

2.80 VACUUM GAUGES

2.81 Air Admiral® Vacuum/Pressure Station Models 79202-30 & 79202-35 come with dial vacuum gauges. The vacuum gauge gives negative pressure - That is pressure below atmospheric. The reference point for the gauge is atmospheric pressure. Please keep in mind that atmospheric pressure tends to vary from day to day. As a result of this variability, the dial vacuum gauge will indicate slightly different maximum vacuum readings from day to day.

SECTION 3: OPERATION

3.10 STARTING PROCEDURES

3.11 Starting a Cole-Parmer Air Admiral® Vacuum/Pressure Station

Before attaching the pump to a system, familiarize yourself with the function and action of the Air Admiral® Vacuum/Pressure Station that you have acquired. Review the power requirements as described in Section 2.60. Cole-Parmer recommends running the pump for a few minutes to warm it up, before use. The warm-up improves the pumps ability to handle humid air. Set the device on a level, sturdy surface so the controls can be easily reached and adjusted.

1. Be sure that the power switch is in the OFF (down) position. Plug in the device and turn the switch to the ON (up) position.
2. Block the intake hose barb and allow the gauge to reach stable vacuum level.
3. Set vacuum level by turning the regulator knob counter-clockwise to increase vacuum or clockwise to decrease vacuum..

Note: This procedure should be performed each time you use this device.

3.12 Cleaning The Device

1. Make sure the ON/OFF switch is in the OFF (down) position.
2. Unplug the device from the wall outlet and allow suction level to drop.
3. Remove the application tube from the intake port.
4. Wipe the outside of the case with a clean, damp cloth after each use.

3.20 LEAK DETECTION

3.21 The importance of eliminating all leaks in a vacuum system is obvious. The pump must remove this added volume of leaked gas to maintain the desired vacuum. Leaks for these pumps can be located by slightly pressuring the system and painting the suspected area with a thick soap solution. Escaping air will produce soap bubbles.

3.30 OPERATING PRESSURE RANGE

3.31 Air Admiral® Vacuum/Pressure Stations are designed to be run from slightly below atmospheric to their maximum vacuum level on the intake side. The pumps also may be run from atmospheric to their maximum rated pressure rating. Consult the Specification Table for the ratings of your specific model (See Section 6, Specifications).

3.40 SHUTDOWN PROCEDURES

3.41 After use, Cole-Parmer recommends the pump be run for about 2 minutes disconnected from the vacuum process. The air pumped through the mechanism will purge out water vapor or droplets of water condensate that may have formed on the inside of the pump. This purge of the pump mechanism helps prevent corrosion.

SECTION 4: MAINTENANCE

4.10 MAINTENANCE PROCEDURES

4.11 Maintaining a Cole-Parmer Air Admiral® Vacuum/Pressure Station

These units are 100% oil-free. The pump employs a non-lube piston and cylinder. No maintenance is necessary for the bearings. All bearings are sealed and permanently lubricated. Lubrication should not be attempted. The units are built for continuous duty operation with the quietness and durability of a diaphragm, but with piston performance.

The Air Admiral® has a service free life-time of 2,000 to 3,000 hours.

The Air Admiral® is not field serviceable.

SECTION 5: TROUBLESHOOTING

5.10 VACUUM PROBLEMS

5.11 Leakage, contamination, and unusual outgassing are the general causes of problems associated with poor vacuum. To operate at maximum efficiency, a system must be thoroughly clean. If the system is completely clean and free from leaks and unwarranted vacuum problems still exist, the Air Admiral® should be checked. A simple criterion for the condition of the pump is the determination of its maximum vacuum capability. This can be accomplished by blocking of the intake and reading the vacuum level on the gauge.

5.20 PRESSURE PROBLEMS

5.21 Leakage and contamination are the general causes of problems associated with poor pressure. To operate at maximum efficiency a system must be thoroughly clean. If the system is completely clean and free from leaks and unwarranted pressure problems still exist, the Air Admiral® should be checked by a service technician.

5.30 TROUBLE SHOOTING GUIDE

Symptoms	Possible Cause	Remedies
Reduced/low vacuum	<ol style="list-style-type: none"> 1. Regulator improperly set. 2. Air leak. 	<ol style="list-style-type: none"> 1. Set regulator vacuum level following operating instructions. 2. Check the tubing and connectors for possible leaks. Attach, tighten or replace.
Device does not start	<ol style="list-style-type: none"> 1. Power cord not plugged in. 2. Defective switch. 3. Vacuum still exists in system. 	<ol style="list-style-type: none"> 1. Plug in the power cord. 2. Contact your service center or distributor. 3. Disconnect tubing from the intake hose barb to release vacuum. Reconnect tubing and turn on the device.
Gauge reads incorrectly	<ol style="list-style-type: none"> 1. Faulty gauge. 	<ol style="list-style-type: none"> 1. Contact your service center for repair
Device runs but gauge reads zero	<ol style="list-style-type: none"> 1. Gauge tubing not connected or is leaking. 	<ol style="list-style-type: none"> 1. Check the tubing and connectors for possible leaks. Attach, tighten or replace.
Device stops running during use	<ol style="list-style-type: none"> 1. Device overheated. 2. Blown fuse or circuit breaker in household circuit. 3. Low voltage to device. 	<ol style="list-style-type: none"> 1. Unplug device and allow to cool for 10 minutes. Plug in and restart. 2. Replace fuse or reset breaker. 3. Too many motor operated appliances on same circuit.

SECTION 6: SPECIFICATION

6.10 SPECIFICATION TABLE

Cole-Parmer Cat. No.	79202-00	79202-05	79202-30	79202-35
Free Air Displacement CFM (L/min)	0.39 (11)	0.32 (9.2)	0.xx (xx)	0.39 (11)
Max. Continuous Pressure PSIG (Pascal)	10 (10 ⁴)	10 (10 ⁴)	xx (xx ⁴)	10 (10 ⁴)
Max. Intermittent Pressure PSIG (Pascal)	33 (3.3 x 10 ⁴)	33 (3.3 x 10 ⁴)	xx (x.x x xx ⁴)	33 (3.3 x 10 ⁴)
Max. Vacuum in.Hg (mm Hg)	21.3 (540)	21.3 (540)	xx.x (xxx)	21.3 (540)
Tubing needed I.D. in (mm)	1/4 (6)	1/4 (6)	1/4 (6)	1/4 (6)
Weight, Unit lbs (Kg)	5 (2.3)	5 (2.3)	5 (2.3)	5 (2.3)
Dimensions, Unit				
L in. (cm)	7-5/16 (18.5)	7-5/16 (18.5)	9-1/8 (91.0)	9-1/8 (91.0)
W in. (cm)	4-3/8 (11.1)	4-3/8 (11.1)	7-5/8 (19.4)	7-5/8 (19.4)
H in. (cm)	8-3/8 (21.3)	8-3/8 (21.3)	8-3/8 (21.3)	8-3/8 (21.3)
Electrical Requirements	115V 60Hz 1Ph wired with N.American 115V plug	230V 50Hz 1Ph wired with Cont. European Schuko plug	115V 60Hz 1Ph wired with N.American 115V plug	230V 50Hz 1Ph wired with Cont. European Schuko plug

SECTION 7: WARRANTY

This Cole-Parmer product is warranted to be free from defects in material and workmanship. This liability of Cole-Parmer under this warranty is limited to servicing, adjusting, repairing, or replacing any unit or component part which in the judgment of Cole-Parmer has not been misused, abused, or altered in any way or damaged by ingestion of foreign material causing impaired performance or rendering it inoperative. Foreign material includes solids, corrosive gases, and recondensed water or solvent vapor. No other warranties are expressed or implied. The method of executing this warranty: servicing, adjusting, repairing, or replacing, shall be at the discretion of Cole-Parmer. Vacuum pumps that have been operated within a vacuum system, or other system, for any period, however short, will be repaired under this warranty rather than replaced.

The warranty is effective for one year from the date of original purchase when:

1. The warranty card has been completed and returned.
2. The product is returned to the factory or other designated service centers, freight prepaid.
3. The product in our judgment is defective through no action or fault of the user.

If the product has become defective through misuse, abuse, alteration, or ingestion of foreign material, repairs will be billed regardless of the age of the product. In this event, an estimate of the repair costs will be submitted and authorization of these charges will be required before the product is repaired and returned.



Cole-Parmer Instrument Company

625 East Bunker Court

Vernon Hills, IL 60061-1844

Phone: 1-800-323-4340

Fax: 847-247-2929

E-Mail: info@coleparmer.com

Web-Page: www.coleparmer.com