

SPECIFICATIONS

Display:	Triple 4 digit LCD.
Over Range Indication:	OL - appears.
Low Battery Indicative:	BT shows up when tire battery's voltage below the operating voltage.
Sampling Rate :	about 1 time per second
Power Requirement:	6pcs 1.5V size AAA alkaline batteries or 12V AC Adaptor / 1A minimum.
Battery Life:	Approx. 72 hours. (except printing and beeper).
Printing Interval:	6 sec to 59 min 59 sec
Operating Temperature and Humidity:	0 to 50°C (32 to 122°F) below 95% RH
Storage Temperature and Humidity:	-10 to 60°C (14 to 140°F) below 70% RH
(Meter):	193 (L) x 74 (W) x 37(H) mm
(Probe):	160 (L) x 13(D) mm/1m cable
Weight:	Approx. 430g with batteries & thermo-paper.
Accessories	Carrying case, Instruction manual, Batteries, 2 Rolls of thermo-paper, type K probe.
Printer:	Thermo-printing tape with 16 characters per line using 38mm width plain thermo-paper.

Electrical Specifications

Humidity:	
Range:	30%RH to 95%RH
Resolution:	0.1%RH
Temperature (T1):	
Range:	-20 to 60°C (-4 to 140°F)
Resolution:	0.1°C / 0.1°F
Dew Point:	
Range:	-44.0 to 58.5°C (-47.2 to 137.3°F)

NAME OF PARTS AND POSITION

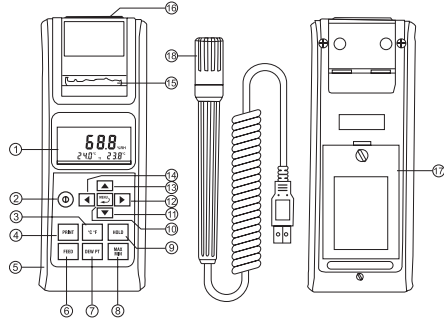

- LCD: Measured values, until, symbols, and decimal points are displayed.
- (CIRCLE): Key for power on/off
- [C/F]: Key for exchanging temperature unit °C and °F.
- [PRINT]:
 - Key for start printing current data. The format as below:

LINE 1 20:12:01 02-21
 LINE 2 58.9%RH
 LINE 3 td 15.7°C
 LINE 4 T1 24.3°C
 LINE 5 T2 24.8°C

- Line 1: printing time hour minute: second, month-day.
 Line 2: printing humidity value.
 Line 3: printing Dew point value.
 Line 4: printing T1 temperature value.
 Line 5: printing T2 temperature value (K-Type).

- Press this button for 2 seconds; the printer will enter interval printing status, and won't stop unless this button is pressed again or FEED button is pressed.

- DC 9V VAC adaptor input jack.

- [FEED] PAPER (Fig-2):
 - Key for moving forward thermo-paper one line.
 - Perform force stop printing, and skip any printing data.

- [DEW POINT]: Key for changing humidity in dew-point display.

- [MAX/MIN]:
 - Press this key one time to enter maximum/minimum record mode, the "REC" symbol is displayed.
 - Press this key to display the maximum reading ("MAXREC" symbol displayed), the minimum reading ("MINREC" symbol displayed) in cycle.
 - Press this key 2 seconds to exit this mode.

- [HOLD]: Key for holding the display reading and press again to exit.
- []: Key for start/stop set-up parameters mode.

Parameters (in sequence):

ON/OFF	(interval printing enable or disable).
TIME INTV	(printing interval ranging from 00m:06s to 59m:59s).
INTV▶	(Interval printing start time ranging from 00h:00m to 23h:59m).
INTV■	(Interval printing stop time ranging from 00h:00m to 23h:59m).
TIME	(Calendar setting year, month, day, hour, minute).

- ▼ DOWN: Key for decreasing the value of parameters.
- ▶ RIGHT: Key for moving to the desired next parameter setting.
- ▲ UP: Key for increasing the value of parameters setting.
- ◀ LEFT: Key for moving to the desired forward

- parameter setting.
- Way out for thermo-paper.
- Type K temperature probe jack.
- Battery cabinet and cover: 6pcs 1.5V size AAA alkaline batteries.
- Humidity (including temperature) probe.

LCD DISPLAY

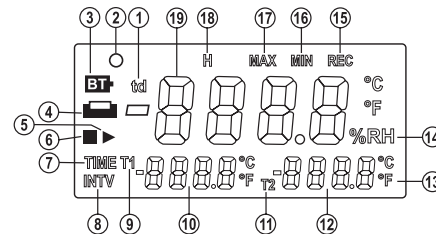

- Dew point measurement indicator.
- Preset interval printing function ON indicator.
- Low battery indicator.
- Printing indicator.
- Interval printing start time setting indicator.
- Interval printing stop time setting indicator.
- Calendar time indicator.
- Interval printing indicator.
- T1 measurement indicator.
- T1 measurement value (NTC).
- T2 measurement indicator.
- T2 measured value (Type-K).
- Temperature measurement units.
- Humidity measurement units.
- Recording indicator.
- Minimum measurement value indicator.
- Maximum measurement value indicator.
- Data hold indicator.
- Humidity and dew point temperature measured value

PRECAUTIONS AND PREPARATIONS FOR MEASUREMENT

- Before operating this instrument, please examine it to make sure no shipping damage occurs. Otherwise notify your dealer.
- Save all packing materials until you are sure that this unit can normally operate.
- Be sure that batteries are correctly placed in the case or adaptive 12V Adaptor is in correct connection.
- An unsecured battery cover will cause error measuring.
- To avoid battery leakage problem, remove batteries if this meter will not be used for a long time.
- Do not use or store this meter outside the operating/storage environment.

OPERATING PROCEDURE

- This meter can be supplied with batteries or DC 12V AC Adaptor. If using batteries: Remove the rear cover, and install batteries, pay attention to the polarity of battery socket. If using 12V

Adaptor, make sure that it is in good connection to the Adaptor socket of the meter. Choose the K-type temperature probe for your application and insert it into T2 the temperature probe socket. Insert Humidity/Temperature (T1) probe into T1 the meter socket.

- Press the [] button to power on the meter, the current date and time will display about 3 seconds. If "----" appears, it indicates no probe or the probe is broken.
- T1 indicates room temperature, T2 indicates K-type thermocouple test value.
- Printing date: Press [PRINT] one time to print one set date. If need continuous printing, press and hold down PRINT button, until LCD display "INTV" mark and enter continuous interval printing mode, the printer will print data as follows:

INTV	00:06	Interval printing time, minute : second
10:55:19	08-16	Printing time, hour:minute:second, month:day
62.7	%RH	Humidity test value and unit.
td	19.8 °C	Dew point and unit
T1	27.6 °C	Room temperature test value and unit.
T2	26.5 °C	K-type thermocouple test value and unit.
10:55:25	08-16	
62.7	%RH	
td	19.8 °C	
T1	27.6 °C	
T2	26.5 °C	
10:55:31	08-16	
62.7	%RH	
td	19.8 °C	
T1	27.6 °C	
T2	26.5 °C	
10:55:37	08-16	
62.8	%RH	
td	19.8 °C	
T1	27.6 °C	
T2	26.5 °C	

Press [PRINT] or [FEED] key to exit printing mode.

- When the meter is powered on, if the printing function setting is "ON", and now time is interval printing start time, the meter will enter to continuous interval printing mode and start printing.

- * Press (PRINT) or (FEED) key to exit printing mode.
- * The interval printing function worked only when the start printing time is earlier than the stop printing time, and interval print time can not be longer than 24 hours.

Caution: Before printing, please check thermo-paper is not clipped by thermo-paper cover, if anything interrupts the printer, the meter will shut off the printer power, and " " symbol flickers.

SETTING MODE

Press [] button to enter setting function, re-press this button can select setting parameters in circle (printer on or off, interval printing time, start printing time and calendar setting). The modifier parameter will flicker until

the setting is finished. Press or button to select parameter setting, press or button to increase or decrease the parameter.

Parameter setting in sequence and LCD display as follows:

1. Parameter function ON or OFF select



2. Interval printing "second" parameter setting.



3. Interval printing "minute" parameter setting.

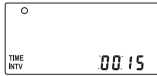

4. Printing start time "minute" parameter setting.



5. Printing start time "hour" parameter setting.



6. Printing stop time "minute" parameter setting.



7. Printing stop time "hour" parameter setting.



8. Calendar "minute" parameter setting.



9. Calendar "hour" parameter setting.



10. Calendar "day" parameter setting.



11. Calendar "month" parameter setting.



12. Calendar year last two digit parameter setting.



HOW TO SETUP INTERVAL PRINT

1. Setup Interval print with 24 hours limitation.
2. Press Key to enter setting mode, setting print operation is ON.
3. Select interval printing time setting mode, set "second", "minute" (from 00:06 to 59:59).
4. Select start printing time setting mode, set "minute", "hour" (from 00:00 to 23:59).
5. When finish the setting, press key to exit the setting mode, LCD will display "⊙" mark at left upper corner.

Note: The start time must be earlier than the stop time, otherwise the buzzer will beep to warning the setting is error and not accept the setting when press key.

BATTERY REPLACEMENT

1. As battery power is not sufficient **BT** will be shown on LCD. Replace with 6 pcs new of 1.5V size AAA batteries is required.
2. After the temperature probe is disconnected and the meter is powered off, remove the battery cover.
3. Remove batteries from the holder and replace it with 6 pcs of new 1.5V size AAA alkaline batteries.
4. Secure the battery cover

ACCESSORIES

- Cat. No. 8182 Paper Rolls (2/pk)
- Cat. No. 8183 AC Power Supply

WARRANTY, SERVICE, OR RECALIBRATION

For warranty, service, or recalibration, contact:

TRACEABLE® PRODUCTS

12554 Old Galveston Rd. Suite B230
Webster, Texas 77598 USA
Ph. 281 482-1714 • Fax 281 482-9448
E-mail support@traceable.com • www.traceable.com

Traceable® Products are ISO 9001:2015 Quality-Certified by DNV and ISO/IEC 17025:2017 accredited as a Calibration Laboratory by A2LA.

TRACEABLE® PRINTING HYGROMETER/ THERMOMETER INSTRUCTIONS