

CLARITY STATION

ATS10230

Miniature Transmission Dip Probe

INSTRUCTION BOOK.

Please take your time to read this Instructions book in order to understand the safe and correct use of your new Bibby Scientific product.

It is recommended the Responsible Body for use of this equipment reads this Instruction book and ensures the user(s) are suitably trained in its operation.

Section 1.	Introduction.	Page 3
Section 2.	Symbols and using this Instruction book.	Page 4
Section 3.	Notes and Warnings	Page 5
Section 4.	Specification	Page 5
Section 5.	Installation	Page 6 – 7
Section 7.	Service and Repair	Page 7
Section 8.	Environmental Protection	Page 7
Section 9.	Customer Support	Page 8
Appendix 'A'	Decontamination Certificate.	Page 9

© The copyright of this instruction book is the property of Bibby Scientific Limited. This instruction book is supplied by Bibby Scientific Limited on the express understanding that it is to be used solely for the purpose for which it is supplied. It may not be copied, used or disclosed to others in whole or part for any purpose except as authorised in writing by Bibby Scientific Limited. Bibby Scientific Limited reserves the right to alter, change or modify this document without prior notification.

In the interest of continued development Bibby Scientific Limited reserve the right to alter or modify the design and /or assembly process of their products without prior notification.

This product is manufactured in Great Britain by Electrothermal, part of the Bibby Scientific Group of companies.

Bibby Scientific Limited.

Beacon Road,
Stone,
Staffordshire ST15 0SA,
Great Britain.

Tel: +44(0)1785 812121

Fax: +44(0)1785 810405

1. Introduction

1.1. The first step in the crystallization process is determining the solubility compound in a selection of solvents and / or solvent mixtures. Unfortunately, determining the solubility of a compound can be labour exhaustive and consume large quantities of material / chemical solution. The Clarity™ Solubility Station provides a quick and inexpensive way of determining the solubility of a compound by monitoring the turbidity of the mixture. The complete system for solubility consists of the following.

- Multi-Channel Infra-Red box (ATS10232E)
- Integrity 10 Reaction Station (PS20000)
- Micro-intrusive IR probe in stainless steel (ATS10230)
- Intrusive IR probe in PEEK (ATS10394/1)
- Non-intrusive IR probe for HPLC vials (ATS10360/1)
- Reflux/Inerting Block (ATS20100)
- Reflux/Inerting PTFE Caps SVL Thread (x10) (ATS20002)
- Multi-Channel temperature box (ATS10001)
- Temperature Probes (x10) (ATS10027/10)
- Reaction tubes (x10) (ATS10075)
- Integrity PC software (ATS11005)

1.2 Electrothermals miniature transmission dip probe is designed for microliter spectroscopic sampling. The diameter of the miniature probe is only 1.5mm – the size of a 17-gauge needle, which enables it to fit into all micro centrifuge tubes, making it a very useful tool for measurement of DNA and protein samples and also can be used for a dissolution system.

2. Symbols and Using this Instruction Book

- 2.1. Throughout this Instruction book the following symbols are shown to identify conditions which pose a hazard to the user, or to identify actions that should be observed. These symbols are also shown on the product, or its packaging. When a symbol is shown next to a paragraph or statement it is recommended the user takes particular note of that instruction in order to prevent damage to the equipment or to prevent injury to one's self or other people.

The Responsible Body and the Operator should read and be familiar with this Instruction book in order to preserve the protection afforded by the equipment.

To prevent injury or equipment damage it is the manufacturer's recommendation that all persons using this equipment are suitably trained before use.

- 2.2. Symbols Defined.



Caution, risk of danger. See note or adjacent symbol.



Protective conductor terminal to be earthed.
(Do not loosen or disconnect).



Caution / Risk of electric shock.



Recyclable Packaging Material.



Do not dispose of product in normal domestic waste.



Caution. Hot surface.

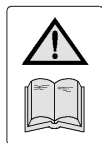

Refer to Instruction book.



Bio Chemical Hazard. Caution required. Will require decontamination.

3. Notes and Warnings

This product has been designed for safe operation when used as detailed in accordance with the Manufacturer's instructions.

NOTE: Failure to use this equipment in accordance with the manufactures operating instructions may compromise your basic safety protection afforded by the equipment and may invalidate your warranty / guarantee. The warranty / guarantee will not cover damaged caused by faulty installation or misuse of the equipment.

3.1. General Safe Operating Practice.



Do NOT use the probe in hydrofluoric acid (HF) or other strong acids. HF dissolves the quartz fiber, and strong acids dissolve the stainless steel body. Avoid and liquids which damage quartz or stainless steel.



Dropping, hitting or bumping can cause permanent damage to the probe. The window area is fragile and the mirror can be knocked out of alignment. When the probe is not in use always protect the tip with the plastic guard provided.



Always store the fiber optic connectors in protective sleeves when they are not connected.



Do not bend sharply or drop heavy objects on the fiber optic cable. Damaging the optical fibers causes loss of light transmission.



Keep the handle of the probe and the fiber optic cable away from hot objects which could melt them.



The miniature transmission probe is a delicate optical device and must always be handled with care.

4. Specification

Tip Diameter	1.5mm
Light Path Length	5mm
Wavelength Range	220 - 900nm
Minimum sample volume	20µl
Fiber Optic Connectors	SMA 905

5. Installation

5.1. Connections

The miniature transmission probe has two fiber optic cables, the launch fiber connects to the light output and the return fiber to the detector input as shown below.

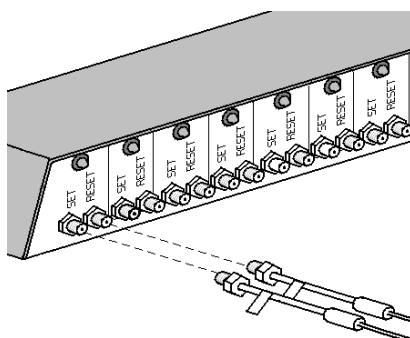
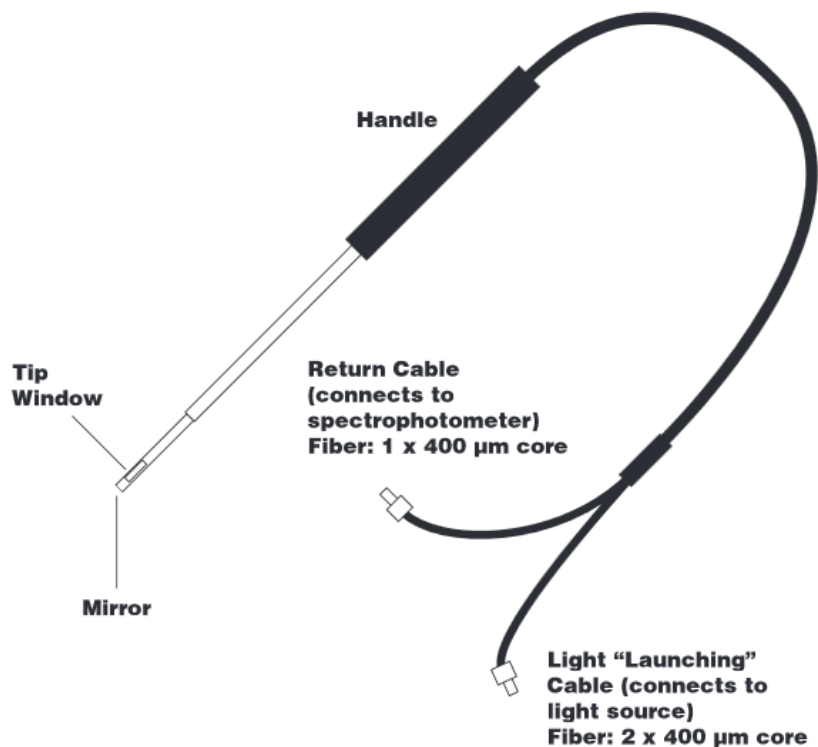

5.2. Wetting the tip

The miniature transmission probe uses a mirror to return the light and it is important to keep the mirror surface clean. When miniature transmission probe is stored dry, a thin film will usually be deposited on the mirror by the liquid left in the tip from the previous usage. It is important to clean the tip by rinsing it in distilled water and keeping it in the water between measurements.

5.3. Taking a measurement

Measurements are taken while the tip is immersed in the sample solution. It is imperative to prevent air bubbles from being trapped in the small window of the tip since bubbles can completely block the light transmission and create invalid results. (A significant base-line shift up may indicate an air bubble interfering with the light transmission.)

Inserting the tip slowly and smoothly into the sample solution will allow the air to escape from the window. Repeat several times if necessary.

Blotting the tip with a lint-free tissue such as Kimwipes and reinserting it into the solution might also help.

Cleaning the tip in detergent and thoroughly rinsing before use helps relieve surface tension at the window, reducing the formation of bubbles.

5.4. Cleaning the tip

After sampling, remove the remaining sample from the tip with a clean wipe to help reduce contamination of your cleaning solutions, then rinse the tip of the probe in distilled water and cleaning solution or just distilled water. Appropriate cleaning solutions include distilled water, detergent and alcohol. The most effective method for cleaning the probe tip is to use an ultrasonic cleaning bath to remove residue that does not rinse out easily.

6. Service and Repair

6.1. *There are no serviceable parts within the miniature transmission dip probe*

7. Environmental Protection

7.1. Maximum consideration has been given to environmental issues within the design and manufacturing process without compromising end product performance and value.



7.2. Packaging materials have been selected such that they may be sorted for recycling.

7.3. This product should only be dismantled for recycling by an authorised recycling company.



This product and accessories must be accompanied by a completed Decontamination Certificate prior to any disposal. Copies of the Certificate are available from your distributor of Bibby Scientific products, or you may copy and enlarge from 'Appendix A' of this instruction book.

Bibby Scientific's Electrothermal branded product range is registered with the Environment Agency under the name of as Electrothermal Engineering Limited as being a producer of WEEE (Waste Electronic and Electrical Equipment) through b2b Compliance, an authorised waste collection compliance scheme.

8. Customer Support

For help and support in using this product, please contact Customer Services at the following address.

Bibby Scientific Limited.
Beacon Road,
Stone,
Staffordshire ST15 0SA,
Great Britain.

Tel: +44(0)1785 812121
Fax: +44(0)1785 810405

- General enquiries :
info@bibby-scientific.com
- Order enquiries :
sales@bibby-scientific.com
- Technical support :
electrothermalhelp@bibby-scientific.com
- www.electrothermal.com

For the America's and Canada, contact:
Techne Incorporated, 3 Terri Lane,
Suite 10 Burlington, NJ 08016 USA.

Toll free:800-225-9243Tel: 609-589-2560
Fax: 609-589-2571
Email: labproducts@techneusa.com
Http www.techneusa.com

APPENDIX 'A'. DECONTAMINATION CERTIFICATE.

<p>Bibby Scientific Limited. Beacon Road, Stone, Staffordshire ST15 0SA. Great Britain Tel: +44(0)1785 812121. Fax: +44(0)1785 810405 E-mail: <u>electrothermalhelp@bibby-scientific.com</u></p>		
<p><u>DECONTAMINATION CLEARANCE CERTIFICATE</u></p>		
<p>For the Inspection, Repair or Return of Medical, Laboratory or Industrial Equipment.</p>		
<p>Prior to a Service Engineer working on equipment that has been in an environment where substances hazardous to health may have been used, you are requested to provide the following information:</p>		
<p>CUSTOMER DETAILS</p>		
<p>Company:-</p>	<p>Address:-</p>	
<p>Department:-</p>		
<p>Contact Name:-</p>		
<p>Tel No:-</p>		
<p>Fax No:-</p>	<p>Post Code:-</p>	
<p><u>Product Description</u></p>		
<p>Model No:-</p>	<p>Serial No:-</p>	
<p>Has the equipment been exposed to any of the following, Please answer all questions by deleting YES/NO as applicable and by providing details in section 2 below.</p>		
<p>A. Blood, body fluids, Pathological specimens</p>	<p>YES/NO</p>	<p>Provide details if YES</p>
<p>B. Biodegradable material that could become a hazard</p>	<p>YES/NO</p>	<p>Provide details if YES</p>
<p>C. Other biohazard</p>	<p>YES/NO</p>	<p>Provide details if YES</p>
<p>D. Chemical or substances hazardous to health</p>	<p>YES/NO</p>	<p>Provide details if YES</p>
<p>E. Radioactive substances State name(s) and quantities of isotopes and checks made for residual activity</p>	<p>YES/NO</p>	<p>Provide details if YES</p>
<p>F. Other hazards</p>	<p>YES/NO</p>	<p>Provide details if YES</p>
<p>2. Please provide details of any hazard present as indicated above. Include details of names and quantities of agents as appropriate:-</p>		
<p>3. Your method of decontamination (please describe):-</p>		
<p>4. Are there likely to be any areas of residual contamination (please specify)</p>		
<p>I declare that the above information is true and complete to the best of my knowledge and belief.</p>		
<p>Authorised signature:-</p>	<p>Name (please print):-</p>	
<p>Title/Position:-</p>		
<p>For and behalf of:-</p>	<p>Date:-</p>	

