

Maintenance, Recalibration, and Repair (continued)

It is recommended that Traceable products are calibrated annually to ensure proper function and accurate measurements; however, your quality system or regulatory body may require more frequent calibrations.

WARRANTY, SERVICE, OR RECALIBRATION

For warranty, service, or recalibration, contact:

TRACEABLE® PRODUCTS
12554 Old Galveston Rd. Suite B230
Webster, Texas 77598 USA
Ph. 281 482-1714 • Fax 281 482-9448
E-mail support@traceable.com
www.traceable.com

Traceable® Products are ISO 9001:2015 Quality-Certified by DNV and ISO/IEC 17025:2017 accredited as a Calibration Laboratory by A2LA.

User Manual

Traceable®

Stick-Style Water-Resistant Infrared Thermometer with 8:1 Distance-to-Sight Ratio

with NIST-Traceable Calibration

Model 20250-09

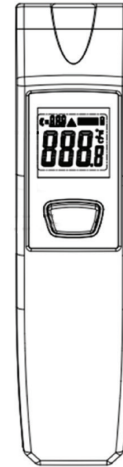

THE STANDARD IN PRECISION MEASUREMENT

Introduction

The Traceable Stick-Style Infrared Thermometer (Model 20250-09) with 8 to 1 distance-to-sight ratio offers fast response and high accuracy at the touch of a button. The built-in laser pointer increases target accuracy while the convenient push button and backlight LCD combine for ergonomic handheld operation. Unit features a dust- and water-resistant IP54 rating. Infrared thermometers can be used to safely measure the temperature of objects that are hard or improper to be measured by traditional contact thermometers. The instrument is fully tested and calibrated to NIST-traceable standards. Careful use of this meter will provide years of reliable service.

Unpacking

Check individual parts against the list of items below. If anything is missing or damaged, please contact your instrument supplier immediately.

1. Meter
2. One 9V battery
3. User manual
4. NIST-traceable calibration report with data

Maintenance, Recalibration, and Repair

Cleaning and Storage

- The meter should be cleaned with a damp cloth and mild detergent when necessary. Do not use solvents or abrasives.
- Store the meter in an area with moderate temperature and humidity

Battery Replacement

If the battery power is insufficient, the **Low-battery** icon will appear on the LCD. Unscrew the battery cover and replace the 9V battery. Rescrew the cover until it is securely closed.

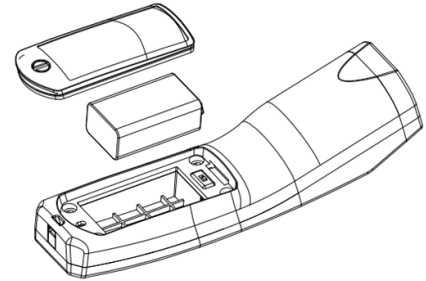

Field of View

The meter's field of view is 8:1, meaning that if the meter is 8 inches from the target, the diameter of the object under test must be

at least 1 inch. Other distances are shown in the diagram above. Make sure that the target is larger than the meter's spot size. The smaller the target, the closer you should be to it. When accuracy is critical, make sure the target is at least twice as large as the spot size.

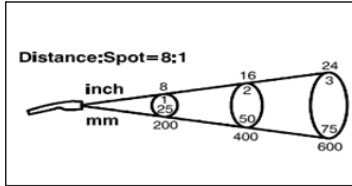

Safety

- Use extreme caution when laser beam is turned on.
- Do not let the laser beam enter your eye, another person's eye or the eye of an animal.
- Be careful not to let the laser beam on a reflective surface strike your eye.
- Do not allow the laser light beam to impinge on any gas which can explode.



Key Features

- 8:1 Distance-to-sight ratio
- 2% basic accuracy
- Precise noncontact IR measurements
- Laser sighting
- Fixed emissivity (0.95)
- User-selectable °F or °C temperature units
- Automatic data Hold
- Backlight LCD
- Automatic power-off to conserve battery life

Meter Description

1. Laser pointer beam
2. IR sensor
3. LCD
4. MEASURE button
5. Battery cover
6. °F/°C switch

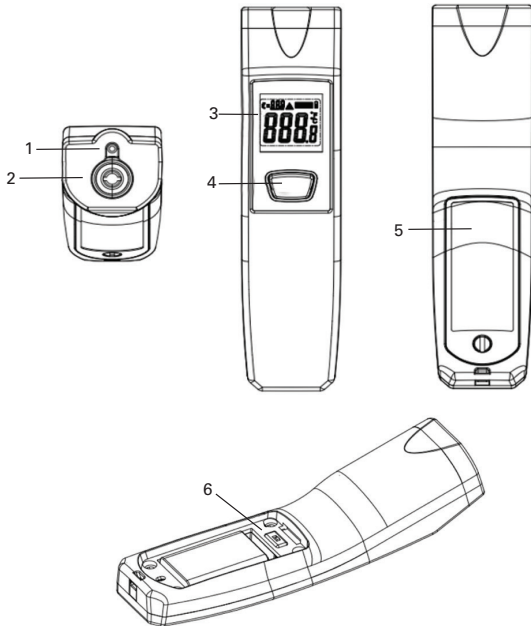

Setup and Operation

1. To select the desired temperature units, open the battery cover and select °F or °C.
2. Hold the meter by its handle grip and point it toward the surface to be measured.
3. Push and hold the MEASURE button to turn the meter on and begin testing. The display will light if the battery is good. Replace the battery if the display does not light.
4. While measuring, the current temperature will appear on the LCD.
5. Release the MEASURE button to hold the reading.
6. **Note:** To conserve battery life, meter automatically powers down in 7 seconds once button is released.

Specifications

Temperature range	0 to 575°F (-18 to 302°C)
Resolution	0.1°F/°C
Accuracy	±3.6°F (2°C) or ±2% of reading
Response time	Less than 150 ms
Emissivity	Fixed at 0.95
Distance-to-sight ratio (field of view)	D/S = Approximately 8:1 ratio (D = distance, S = spot)
Laser	Single Class 2 (II) laser
Spectral range	8 to 14 μm
Operating temperature	32 to 122°F (0 to 50°C)
Storage temperature	14 to 140°F (-10 to 60°C)
Dimensions	7" x 1¼" x 1½" (17.8 x 4.4 x 3.8 cm)
Power	One 9 V battery

How it Works (continued)

Good Measuring Practices

Holding the meter by its handle, point the IR sensor toward the object whose temperature is to be measured. The meter automatically compensates for temperature deviations from ambient temperature. Keep in mind that it will take up to 30 minutes for the IR sensor to stabilize if going from ambient temperatures to a much higher (or lower) temperature measurement.

Reminders

- The unit is not recommended for measuring shiny or polished metal surfaces (stainless steel, aluminum, etc.). See **Emissivity** on page 7.
- The unit cannot measure through transparent surfaces such as glass. It will measure the surface temperature of the glass instead.
- Steam, dust, smoke, etc. can prevent accurate measurement by obstructing the unit's optics.

Display Layout

1. Emissivity value
2. Laser pointer indicator
3. Data HOLD icon
4. Low-battery indicator
5. °F and °C temperature icons
6. Temperature readout



How it Works

Infrared thermometers measure the surface temperature of an object. The unit's optics sense emitted, reflected, and transmitted energy, which is collected and focused onto a detector. The unit's electronics translate the information into a temperature reading which is displayed on the unit. The laser is used for aiming purposes only.

Field of View

Make sure that the target is larger than the unit's spot size. The smaller the target, the closer you should be to it. When accuracy is critical, make sure the target is at least twice as large as the spot size.

Distance and Spot Size

As the distance (D) from the object increases, the spot size (S) of the area measured by the unit becomes larger.

Locating a Hot Spot

To find a hot spot, aim the thermometer outside the area of interest, then scan across with an up-and-down motion until you locate the hot spot.

Emissivity

Emissivity is a term used to describe the energy-emitting characteristics of materials. Most (90% of typical applications) organic materials and painted or oxidized surfaces have an emissivity of 0.95 (fixed in the unit). Inaccurate readings will result from measuring shiny or polished metal surfaces. To compensate, cover the surface to be measured with black tape or flat black paint. Allow time for the tape to reach the same temperature as the material underneath it. Measure the temperature of the tape or painted surface. (Refer to table below.)

Substance	Thermal emissivity	Substance	Thermal emissivity
Asphalt	0.90 to 0.98	Cloth (black)	0.98
Concrete	0.94	Human skin	0.98
Cement	0.96	Lather	0.75 to 0.80
Sand	0.90	Charcoal (powder)	0.96
Earth	0.92 to 0.96	Lacquer	0.80 to 0.95
Water	0.92 to 0.96	Lacquer (matte)	0.97
Ice	0.96 to 0.98	Rubber (black)	0.94
Snow	0.83	Plastic	0.85 to 0.95
Glass	0.90 to 0.95	Timber	0.90
Ceramic	0.90 to 0.94	Paper	0.70 to 0.94
Marble	0.94	Chromium oxides	0.81
Plaster	0.80 to 0.90	Copper oxides	0.78
Mortar	0.89 to 0.91	Iron oxides	0.78 to 0.82
Brick	0.93 to 0.96	Textiles	0.90