

## Safety

- Use extreme caution when the laser beam is turned on.
- Do not let the laser beam enter your eye, another person's eye or the eye of an animal.
- Be careful not to let the laser beam on a reflective surface strike your eye.
- Do not allow the laser light beam to impinge on any gas which can explode.



## Maintenance, Recalibration, and Repair

### Cleaning and Storage

- The meter should be cleaned with a damp cloth and mild detergent when necessary. Do not use solvents or abrasives.
- Store the meter in an area with moderate temperature and humidity (refer to the specifications on page 11).

### Battery Replacement

If the battery power is insufficient, the **Low-battery** icon will appear on the LCD. Open the battery cover and replace the 9 V battery. Securely close the cover.

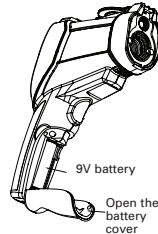

It is recommended that Traceable products are calibrated annually to ensure proper function and accurate measurements; however, your quality system or regulatory body may require more frequent calibrations.

## WARRANTY, SERVICE, OR RECALIBRATION

For warranty, service, or recalibration, contact:

**TRACEABLE® PRODUCTS**  
12554 Old Galveston Rd. Suite B230  
Webster, Texas 77598 USA  
Ph. 281 482-1714 • Fax 281 482-9448  
E-mail [support@traceable.com](mailto:support@traceable.com)  
[www.traceable.com](http://www.traceable.com)

Traceable® Products are ISO 9001:2015 Quality-Certified by DNV and ISO/IEC 17025:2017 accredited as a Calibration Laboratory by A2LA.

## User Manual

**Traceable®**

**Professional Dual-Laser Infrared Thermometer  
with 50:1 Distance-to-Sight Ratio, Data Logging,  
USB Output, Single Type K Input,  
and Temperature Alarm**

with NIST-Traceable Calibration

**Model 20250-08**

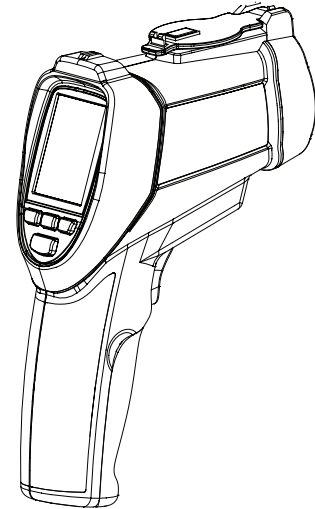

## Introduction

The Traceable Professional Dual-Laser Infrared Thermometer (Model 20250-08) with 50 to 1 distance-to-sight ratio offers fast response and high accuracy. This heavy-duty meter is ideal for a wide range of applications including food preparation, safety and fire inspection, plastic molding, marine, HVAC, and fleet maintenance. Advanced features include internal data logging, USB interface for data transmission, temperature alarm, adjustable emissivity, temperature differential, data Hold, Max/Min/Avg readings, and auto power-off. The meter also supports contact measurement through a type K thermocouple input. The instrument is fully tested and calibrated to NIST-traceable standards. Careful use of this meter will provide years of reliable service.

## Unpacking

Check individual parts against the list of items below. If anything is missing or damaged, please contact your instrument supplier immediately.

1. Meter
2. One type K flexible probe
3. USB cable
4. Software
5. Tripod
6. Carrying case
7. One 9 V battery
8. User manual
9. NIST-traceable calibration report with data

10. To save the measurement data to your PC, select "File" icon from the menu bar and save data to desired location on your PC. **Note:** Data will be saved in an Excel format that will include all summary information as captured on the "Data Summary" tab.
11. To print recorded data, simply select the "print" icon on the menu bar.
12. Refer to the "Recording/Data Logging Operation (Meter)" section on page 9 to see how to clear stored data so that new data values can be collected.
13. On the menu bar, select HELP to read detailed information on the capabilities of this software.

## Specifications

IR temperature range	-58 to 3362°F (-50 to 1850°C)
T/C temperature range	-58 to 2498°F (-50 to 1370°C)
Resolution	0.1°F/C below 1000°, 1°F/C above 1000°
IR accuracy	From -58 to 68°F (-50 to 20°C): ±5.4°F (3°C) From 68 to 932°F (20 to 500°C): ±1.0% ± 1.8°F (1°C) From 932 to 1832°F (500 to 1000°C): ±1.5% ± 3.6°F (2.0°C) From 1832 to 3362°F (1000 to 1850°C): ±2.0%
T/C accuracy	From -58 to 1832°F (-50 to 1000°C): ±1.5% of reading ± 5°F (±3°C) From 1832 to 2498°F (1000 to 1370°C): ±1.5% of reading ± 3.6°F (±2°C)
IR response time	150 ms
Emissivity	Adjustable from 0.10 to 1.0
Distance-to-sight ratio (field of view)	D/S = approximately 50:1 ratio (D = distance, S = spot)
Laser	Dual Class 2 (II) lasers
Spectral range	8 to 14 µm
Out-of-range indication	LCD will show "----"
Operating temperature	32 to 122°F (0 to 50°C)
Storage temperature	14 to 140°F (-10 to 60°C)
Weight	17.4 oz (494 g)
Dimensions	7½" x 6" x 2¼" (18.9 x 15.2 x 5.7 cm)
Power	One 9 V battery

## Field of View

The meter's field of view is 50:1, meaning that if the unit is 50 inches from the target, the diameter of object under test must be at least 1 inch. Other distances are shown in the diagram at right. Make sure that the target is larger than the meter's spot size. The smaller the target, the closer you should be to it. When accuracy is critical, make sure the target is at least twice as large as the spot size. As the distance (D) from the object increases, the spot size (S) of the area measured by the meter becomes large. The relationship between distance and spot size is shown above. The focal point is 36" (914 mm). The spot sizes indicate 90% encircled energy.

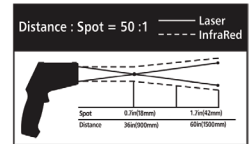

## Recording/Data Logging Operation (Software)

First install the software on PC following the setup wizard. Once software is successfully installed, the data logging icon shortcut will be automatically placed on your PC desktop.

### Real-Time Data Logging

1. Connect the meter to your PC via the supplied USB cable.
2. Power the meter on and select scanning mode.
3. Open the installed Data Logger Software by double-clicking on the icon on your PC desktop.
4. The software will automatically detect the meter and start to download the data to your PC. **Note:** Meter must be in scanning mode for the data to transfer to your PC. The software screen will display the data being transferred from the meter in real-time. The data results will be displayed graphically and numerically for each reading taken.
5. To save the measurement data to your PC, select "File" icon from the menu bar and save data to desired location on your PC. **Note:** Data will be saved in an Excel® format that will include all summary information as captured on the "Data Summary" tab.
6. To print recorded data, simply select the "print" icon on the menu bar.
7. On the menu bar, select HELP to read detailed information on the capabilities of this software.

### Downloading Stored Data from Meter

1. Record up to 100 readings directly onto the meter. Refer to the "Recording/Data Logging Operation (Meter)" section on page 9 for detailed instructions.
2. Open the installed Data Logger Software by double-clicking on the icon on your PC desktop.
3. Locate the time interval drop-down menu in the software and select **(Datalog/60min)**.
4. Power the meter on and activate the **LOG** mode on the IR thermometer.
5. Press and hold the **Backlight/Laser** button to also activate **USB** mode.
6. Connect the meter to your PC and wait for the ONLINE indicator in the software to verify the connection.
7. Use the **Down ▼** button to scroll through logged data points, until **SLOG** is shown in the display.
8. Press the **Backlight/Laser** button once to transmit logged data points to the software. All 100 data points will be sent to the PC, but there will only be temperature values present if the data point (position) was previously logged. **Note:** The time and date stamp will only tell you the time at which the data was transferred, not when the data was originally measured.
9. Data results will be displayed graphically and numerically for each reading taken.

## Key Features

- 50:1 Distance-to-sight ratio
- 1.5% basic accuracy
- Dual laser sighting
- Internal data logging up to 100 IR readings
- USB interface for transmission of data to PC
- Contact measurements via type K thermocouple input
- Precise noncontact IR measurements
- Rapid detection function
- Adjustable emissivity from 0.10 to 1.0
- User-selectable °C or °F units
- Automatic data Hold
- MAX/MIN/AVG temperature displays
- Temperature differential
- High and low alarms (audible)
- Automatic selection range and display resolution
- Trigger lock
- Backlight LCD
- Automatic selection range and display resolution
- Automatic power-off to conserve battery life

## Meter Description

1. IR sensor
2. Laser pointer beam
3. Type K thermocouple input
4. USB computer interface
5. LCD
6. Up ▲ button
7. Backlight ✨ / Laser button
8. Down ▼ button
9. MODE button
10. Lens cover with magnetic lock
11. Measurement trigger
12. Battery cover
13. Handle grip

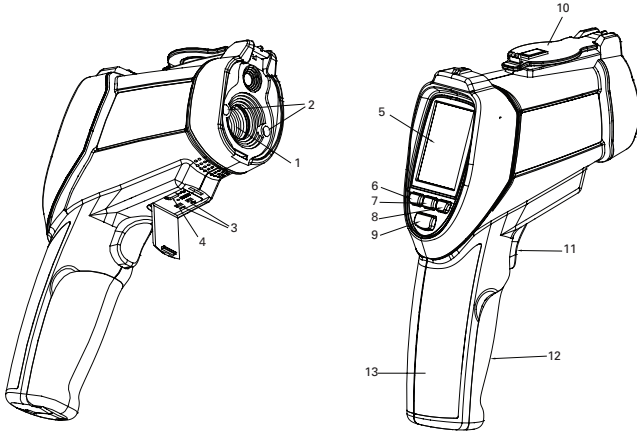

## Recording/Data Logging Operation (Meter)

This meter is capable of storing up to 100 IR temperature readings into internal memory.

### Storing Data

1. While holding the trigger, press the **MODE** button until the **LOG** icon appears in the lower left corner of the screen. A LOG location number will be shown in the top display and a LOG location number will be shown in the top display and “\_ \_ \_” will appear in the bottom display if no temperature has been saved to that location (Fig. 1).
2. Press the **Backlight/Laser** button to log a temperature reading into an empty location (Fig. 2); a short beep will sound. If that location has already been used, you can use the **Up ▲** and **Down ▼** buttons to move to an empty location.

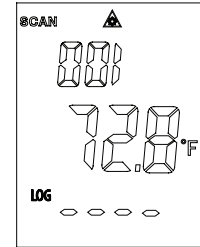

Fig. 1

### Recalling Stored Data

1. Press the **MODE** button until the **LOG** icon appears in the lower left corner of the display. A LOG location number will be shown in the top display and the stored temperature for that location will be shown in the bottom display (Fig. 2).
2. To move to another **LOG** location, use the **Up ▲** and **Down ▼** buttons.

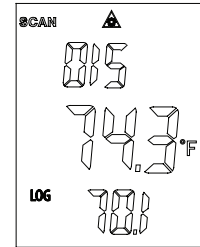

Fig. 2

### Clearing Stored Data

1. While in **LOG** mode, hold the trigger, and use the **Up ▲** and **Down ▼** buttons until you reach LOG location “000” (Fig. 3). This can only be done when the trigger is being pulled, otherwise LOG location “000” cannot be accessed.
2. When LOG location “000” is shown in the top display, press the **Backlight/Laser** button. Three short beeps will sound and the LOG location will automatically change to “001”, signifying that all data locations have been cleared.
3. **Note:** Only use the clear function if you want to clear all the stored data.

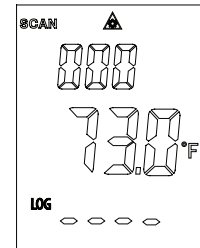

Fig. 3



## How it Works

Infrared thermometers measure the surface temperature of an object. The unit's optics sense emitted, reflected, and transmitted energy, which is collected and focused onto a detector. The unit's electronics translate the information into a temperature reading which is displayed on the unit. The laser is used for aiming purposes only.

### Field of View

Make sure that the target is larger than the unit's spot size. The smaller the target, the closer you should be to it. When accuracy is critical, make sure the target is at least twice as large as the spot size.

### Distance and Spot Size

As the distance (D) from the object increases, the spot size (S) of the area measured by the unit becomes larger.

### Locating a Hot Spot

To find a hot spot, aim the thermometer outside the area of interest, then scan across with an up-and-down motion until you locate the hot spot.

### Emissivity

Emissivity is a term used to describe the energy-emitting characteristics of materials. Most (90% of typical applications) organic materials and painted or oxidized surfaces have an emissivity of 0.95 (preset in the unit). Inaccurate readings will result from measuring shiny or polished metal surfaces. To compensate, cover the surface to be measured with black tape or flat black paint. Allow time for the tape to reach the same temperature as the material underneath it. Measure the temperature of the tape or painted surface. (Refer to table on facing page.)

### Good Measuring Practices

Holding the meter by its handle, point the IR sensor toward the object whose temperature is to be measured. The meter automatically compensates for temperature deviations from ambient temperature. Keep in mind that it will take up to 30 minutes for the IR sensor to stabilize if going from ambient temperatures to a much higher (or lower) temperature measurement.

### Reminders

- The unit is not recommended for measuring shiny or polished metal surfaces (stainless steel, aluminum, etc.). See **Emissivity** above.
- The unit cannot measure through transparent surfaces such as glass. It will measure the surface temperature of the glass instead.
- Steam, dust, smoke, etc. can prevent accurate measurement by obstructing the unit's optics.

## Emissivity Values

Substance	Thermal emissivity	Substance	Thermal emissivity
Asphalt	0.90 to 0.98	Cloth (black)	0.98
Concrete	0.94	Human skin	0.98
Cement	0.96	Lather	0.75 to 0.80
Sand	0.90	Charcoal (powder)	0.96
Earth	0.92 to 0.96	Lacquer	0.80 to 0.95
Water	0.92 to 0.96	Lacquer (matte)	0.97
Ice	0.96 to 0.98	Rubber (black)	0.94
Snow	0.83	Plastic	0.85 to 0.95
Glass	0.90 to 0.95	Timber	0.90
Ceramic	0.90 to 0.94	Paper	0.70 to 0.94
Marble	0.94	Chromium oxides	0.81
Plaster	0.80 to 0.90	Copper oxides	0.78
Mortar	0.89 to 0.91	Iron oxides	0.78 to 0.82
Brick	0.93 to 0.96	Textiles	0.90

## Setup and Operation

1. Hold the meter by its handle grip and point it toward the surface to be measured.
2. Pull and hold the trigger to turn the meter on and begin testing. The display will light if the battery is good. Replace the battery if the display does not light. Meter automatically powers down after 10 seconds once the trigger is released.
3. While measuring, the **SCAN** icon will appear in the upper left-hand corner of the LCD.
4. Release the trigger and the **HOLD** icon will appear at the top of the LCD, indicating that the reading is being held.
5. While in the **HOLD** mode, press the **MODE** button to access and set the Max/Min/Avg/Dif readings, emissivity (EMS) value, trigger lock (on/off), high alarm (on/off and set point), low alarm (on/off and set point), and temperature units (°C or °F). Each time you press the **MODE** button, you advance through each option. Refer to the flow chart on page 8 to see the sequence of functions in the mode cycle.
  - a. **Emissivity (EMS)**. When the **Emissivity** icon is flashing, use the **Up ▲** and **Down ▼** buttons to adjust the value from 0.10 to 1. Then press the **MODE** button again to enter setting. **Note:** If the type K thermocouple is connected, you cannot adjust emissivity.
  - b. **Trigger Lock**. Use for continuous monitoring of temperatures. When the **Lock** icon is flashing, use the **Up ▲** or **Down ▼** button to turn "on". Then press the **MODE** button again to enter setting. Once you press the measurement trigger, the **Lock** icon is shown, confirming the lock measurement mode. The meter will continuously display the temperature until the measurement trigger is pressed again.