

Maintenance, Recalibration, and Repair (continued)

Battery Replacement

When the battery power falls low, the **low-battery** icon will appear on the screen. Replace the three AAA batteries by removing the screw holding the rear battery compartment cover to access the battery compartment. Ensure that the compartment cover is securely fastened when finished. **Note:** If you do not intend to use the meter for a long time, remove the batteries.

It is recommended that Traceable products are calibrated annually to ensure proper function and accurate measurements; however, your quality system or regulatory body may require more frequent calibrations.

WARRANTY, SERVICE, OR RECALIBRATION

For warranty, service, or recalibration, contact:

TRACEABLE® PRODUCTS
12554 Old Galveston Rd. Suite B230
Webster, Texas 77598 USA
Ph. 281 482-1714 • Fax 281 482-9448
E-mail support@traceable.com
www.traceable.com

Traceable® Products are ISO 9001:2015 Quality-Certified by DNV and ISO/IEC 17025:2017 accredited as a Calibration Laboratory by A2LA.

User Manual

Traceable®

Thermocouple Thermometer with Single Type K/J Input

with NIST-Traceable Calibration

Model 20250-01

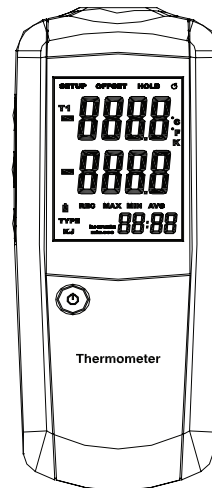

THE STANDARD IN PRECISION MEASUREMENT

Introduction

The Traceable Thermocouple Thermometer with Single Type K/J Input (Model 20250-01) offers fast response and high accuracy. This thermometer works with one type K or J thermocouple sensor. Advanced features include relative time clock, offset compensation, data Hold, Max/Min/Avg readings, and automatic power-off. The instrument is fully tested and calibrated to NIST-traceable standards. Careful use of this meter will provide years of reliable service.

Unpacking

Check individual parts against the list of items below. If anything is missing or damaged, please contact your instrument supplier immediately.

1. Meter
2. One flexible type K thermocouple probe
3. Three AAA batteries
4. User manual
5. NIST-traceable calibration report with data

Specifications

Range	
Type K thermocouple	-328 to 2501°F (-200 to 1372°C)
Type J thermocouple	-346 to 2012°F (-210 to 1100°C)
Resolution	
Temperature display	0.1 below 1000 or 1 above 1000
Accuracy	
Temperature above -148°F (-100°C)	±[0.5% rdg + 1.8°F (1°C)]
Temperature below -148°F (-100°C)	±[0.5% rdg + 3.6°F (2°C)]

Auto power-off	Unit shuts off automatically after 20 minutes to preserve battery life
Operating temperature	32 to 122°F (0 to 50°C)
Storage temperature	14 to 122°F (-10 to 50°C)
Weight	6.2 oz (177 g)
Dimensions	6 ³ / ₈ " x 2 ¹ / ₂ " x 1 ¹ / ₈ " (16.2 x 6.4 x 2.9 cm)
Power	Three AAA batteries

Maintenance, Recalibration, and Repair

Cleaning and Storage

- The meter should be cleaned with a damp cloth and mild detergent when necessary. Do not use solvents or abrasives.
- Store the meter in an area with moderate temperature and humidity (refer to the operating and storage ranges in the specifications chart earlier in this manual).

Measuring Temperatures

1. Plug the thermocouple into the T1 input connector.
Make sure that the polarity is correct.
2. Press **power on/off** button to turn on the thermometer.
After one second the thermometer displays the first reading. If no thermocouple is plugged into the selected input or the thermocouple is not connected properly, the display shows "- - -". If the temperature being measured is outside the thermocouple's valid range, the display shows "OL" (overload).
3. Set the thermometer for the correct thermocouple type (K or J) in Setup menu.
4. Press **°C/°F/K** button to select the desired temperature scale.

Hold Function

1. Press **▲/Hold** button to freeze the readings on the display. The display shows the **HOLD** icon.
2. Press **▲/Hold** button again to turn off the Hold function.

Min/Max/Avg Function

1. Press **Max/Min/▼** button to step through the maximum (MAX), minimum (MIN), and average (AVG) readings. The elapsed time since entering Max/Min mode, or the time at which the maximum or minimum reading occurred, appears on the display.
2. Press and hold **Max/Min/▼** button for 3 seconds to exit Max/Min mode.

Key Features

- Large backlit display
- Max, Min, and Avg readings
- Relative time clock on Max/Min/Avg provides a time reference for major events
- Electronic Offset function allows compensation of thermocouple errors to maximize overall accuracy
- User-selectable readout in °C, °F, or Kelvin (K)
- Automatic power-off (sleep) mode to conserve battery life
- Accepts a wide variety of thermocouple type K and J probes

Meter Description

1. Temperature sensor input
2. LCD
3. **Power on/off** button
4. **Enter** button
5. **Set** button
6. **°C/°F/K** button
7. **▲ (Up)/Hold** button
8. **Max/Min/▼ (Down)** button
9. **☀ Backlight** button

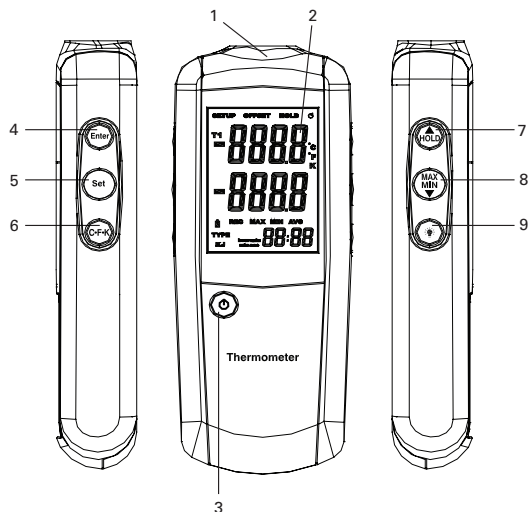

Using the Offset to Adjust for Probe Errors

Use the offset option in the Setup mode to adjust the thermometer's readings to compensate for the errors of a specific thermocouple. The allowable adjustment range is $\pm 9.0^{\circ}\text{F}$ or $\pm 5.0^{\circ}\text{C}$.

1. Plug the thermocouple into the input connector.
2. Place the thermocouple in a known, stable temperature environment (such as an ice bath).
3. Allow the readings to stabilize.
4. In the Setup mode change the offset until the primary reading matches the calibration temperature. (See "Changing Setup Options" on page 7.)

Auto Power-Off (APO) Mode

The meter's default mode is to automatically shut off after 20 minutes of non-use. To disable the auto power-off mode, enter the Setup mode.

1. While in Setup mode, press **▲/Hold** button or **Max/Min/▼** button to scroll to the "SLP" option screen (see Fig. 2).
2. Press **ENTER** button to display "On."
3. Use the **▲/Hold** button or **Max/Min/▼** button to toggle between "On" (sleep mode on) or "Off" (sleep mode off).

Note: Mode defaults back to "On" once meter is powered off.

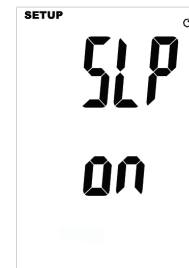

Fig. 2

Setup Mode (continued)

3. Press **Enter** button to indicate that you want to change the probe type.
4. The probe type (K or J) currently in use will be displayed under the **TYPE** icon.
5. Press **▲/Hold** button or **Max/Min/▼** button to toggle between type K and J.
6. Press **Enter** button to store the probe type in memory.

Offset Function

The primary display shows the temperature plus the offset and the secondary display shows the offset.

1. When the thermometer is in Setup mode, the display shows the **SETUP** icon.
2. Press **▲/Hold** button or **Max/Min/▼** button to scroll to the OFFSET setup option page (see Fig. 1).
3. Press Enter button to indicate the offset in the secondary display.
4. Press **▲/Hold** button or **Max/Min/▼** button until the value you want to use appears on the display.
5. Press **Enter** button to store the new setting into memory.



Fig. 1

Display Layout

1. Setup mode icon
2. Offset option
3. Hold icon
4. Auto power-off icon
5. Primary temperature display
6. User-selectable temperature units (°C/°F/K)
7. Secondary display (Max, Min, Avg, or offset)
8. MAX, MIN, AVG icons
9. Time display
10. Time icon (hour:min or min:sec)
11. Thermocouple type icon (K or J)
12. Low-battery indicator

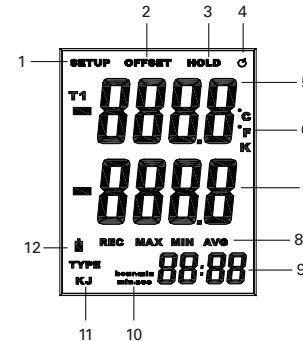

Setup and Operation

1. Press **Power on/off** button to turn the unit on.
2. When thermometer is in Setup mode, press **Enter** button to enter a setup option and press **Enter** button again to store the displayed setting in memory.
3. Press **Set** button to enter or exit Setup mode. (See "Changing Setup Options" on page 7.)
4. Press **°C/°F/°K** button to switch between Celsius (°C), Fahrenheit (°F), and Kelvin (K).
5. Press **▲/Hold** button to freeze or unfreeze the displayed readings. When the thermometer is in Setup mode, press **▲/Hold** button to scroll to the Setup option you want to change or press **▲/Hold** button to increase the displayed setting.
6. Press **Max/Min/▼** button to step through the maximum, minimum, and average of the logged readings. When reading, the screen will indicate the MAX, MIN, or AVG icon. To exit the Max/Min/Avg mode, press and hold **Max/Min/▼** button for three seconds to return to normal operation. When the thermometer is in Setup mode, press **Max/Min/▼** button to scroll to the Setup option you want to change or press **Max/Min/▼** button to decrease the displayed setting.
7. Press **Backlight** button to the backlight on or off.

Setup Mode

Use Setup mode to change offset and sleep mode settings. The thermometer stores the settings in its memory.

Option	Menu item	Settings
Type	TYPE	K or J
Offset	OFFSET	Offset range -9 to 9°F (-5 to 5°C)
Sleep mode	SLP	On (sleep mode on) Off (sleep mode off)

Entering or Exiting Setup Mode

When the thermometer is in Setup mode, the display shows the **SETUP** icon. Press **Set** button to enter or exit the Setup mode.

Changing Setup Options

1. Press **▲/Hold** button or **Max/Min/▼** button to scroll to the setup option you want to change.
2. Press **Enter** button to indicate that you want to change this setting.
3. Press **▲/Hold** button or **Max/Min/▼** button until the setting you want to use appears on the display.
4. Press **Enter** button to store the new setting in memory.

Note: Setup is disabled in MAX/MIN mode.

Selecting a Probe Type

1. When the meter is in Setup mode, the display shows the **SETUP** icon.
2. The screen will display the **TYPE** icon in the lower left-hand corner.