



Warnings and cautions

- > Low pressure gauges can very easily be over pressured if not careful. Please take caution when applying pressures.
- > Do NOT exceed the safety pressure limit (3500 psi / 235 Bar).
- > This pump is not designed to be used in explosive or corrosive environments.
- > Do not switch between pressure and vacuum mode under pressure. Make sure you have vented the pressure and opened the isolation valve before switching to vacuum.
- > Over tightening connectors may cause damage.
- > Pump should be stored in a dry/clean environment.
- > Additel is not liable for any safety problems or damages caused by misuse or incorrect operation.
- > Do NOT hold pressure above 1000 psi for more than 4 hours.
- > All moisture and contaminants should be cleaned out of the liquid isolator before creating a vacuum. This is accomplished by venting the pump when at high pressure.
- > For the least risk in contamination of the reference gauge, the DUT should be installed to the pressure port which is closest to the vent valve.

Specification

- > **Pressure range:** 95% vacuum to 3000 psi (200 bar)
(Based on an atmospheric pressure of 1 bar)
- > **Temperature:** 0 to 50 °C / 32 to 122 F
- > **Humidity:** < 85%RH
- > **Adjustment resolution:** 0.001psi (0.1mbar, 10 Pa)
- > **Overpressure Safety Limit:** 3500 psi (235 bar)
- > **Pressure media:** Air
- > **Weight:** 14.4 lbs (6.5 kg)

*Remark: If local atmosphere pressure is 1 bar, the vacuum can reach to -0.95 bar;
If local atmosphere pressure is P, the vacuum can reach to - 0.95P bar.*

ADT920

Pneumatic High Pressure Test Pump User's Manual

[Version number:1407V02]



Air routine

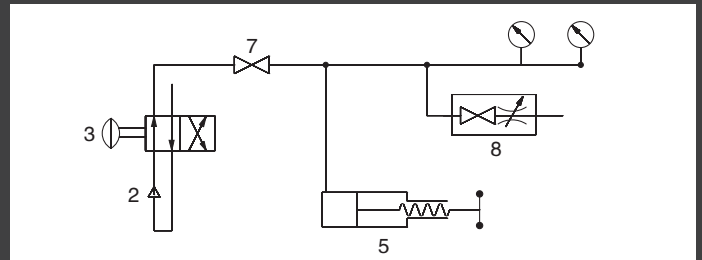

Configuration & Size

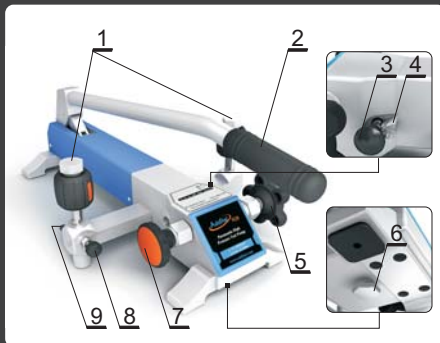

- 1 - Quick connector
- 2 - Hand pump
- 3 - Pressure/vacuum (P/V) selector
(Positive pressure: pull it out; Vacuum: push it in)
Do NOT switch while unit is under any pressure
- 4 - Pressure/Vacuum lock
- 5 - Fine adjust handle
(Turn Clockwise to increase pressure)
- 6 - Maintenance cleaning port
- 7 - Isolation valve
(isolates the calibration volume from the hand pump and check valve)
- 8 - Vent valve
(clockwise to close/counter clockwise to release pressure)
- 9 - Vent port

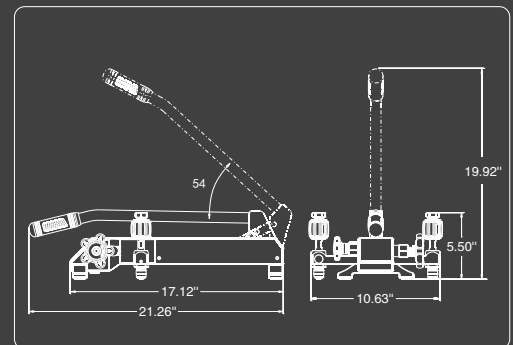

Troubleshooting

| Problem | Cause | Solution |
|--------------------------------------|---|--|
| Hand pump will not generate pressure | The isolation valve is not open. | Open the isolation valve. |
| It is difficult to increase pressure | A. Vent valve is not closed. | Close the vent valve. |
| | B. The O-ring seal is loose or damaged | Replace O-ring seal. |
| | C. P/V selector is in the wrong position. | Pressure : Pull P/V selector out; Vacuum : Push the P/V select or in. |
| | D. Internal tubing is dirty. | Disassemble and clean (Request diagram). |
| Hard to use fine adjust | A. The isolation valve is not closed. | Close the isolation valve. |
| | B. The gauges are not tightened. | Tighten the reference gauge and / or the gauge under test. |
| | C. The O-ring seal is aged or frayed. | Replace O-ring seal. |
| | D. The connector type is mismatched to the gauge pressure port. | Use the correct adaptor. |
| | E. Air route is blocked/dirty. | Pressurize to high pressure and release pressure quickly via the vent valve. |
| Not easy to turn fittings | A. Too much force was previously applied. | Do not over tighten. Hand tight is sufficient. |
| | B. The threads have no lubrication. | Lubricate the thread. |
| | C. The connector type is mismatched to the gauge pressure port. | Use the correct adaptor. |

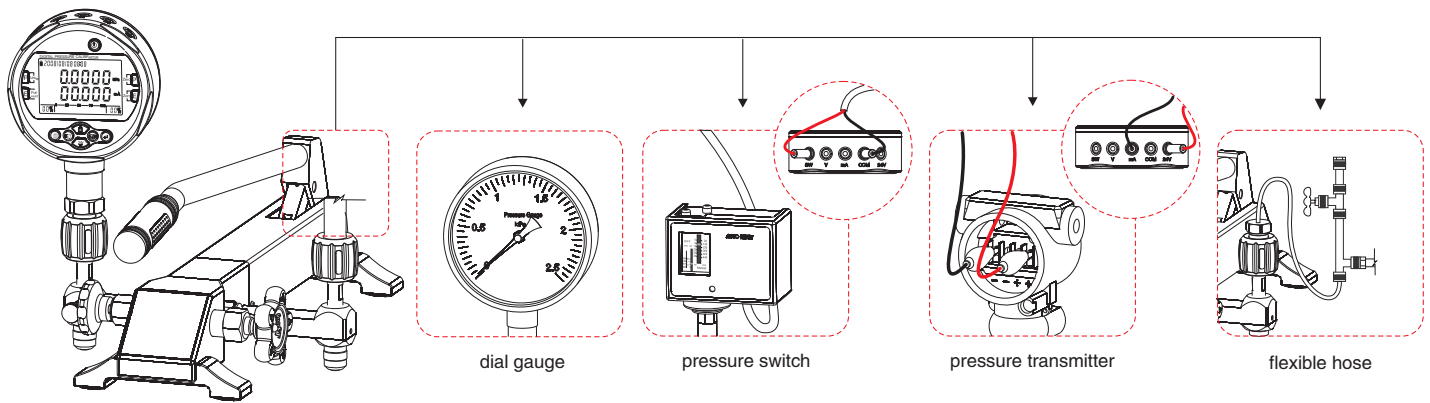

Vent

B

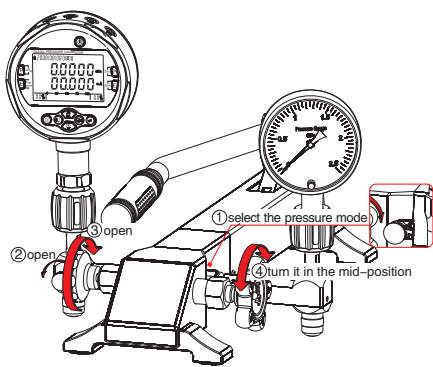

Zeroing should be operated under this condition only.

Increase pressure process

C

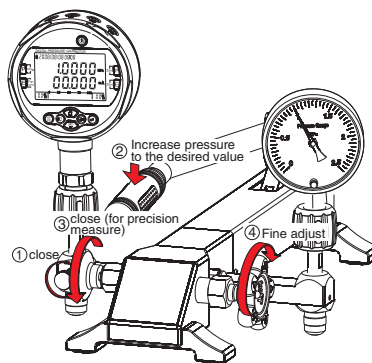

Decrease pressure process

D

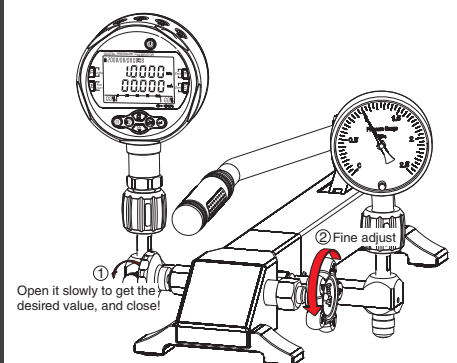

Prepare for vacuum

E

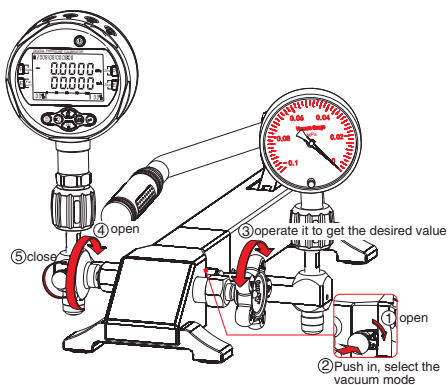

⚠ Open to atmosphere before operation

Vacuum process

F

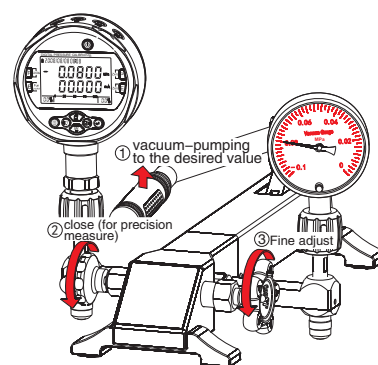

Decrease vacuum process

G

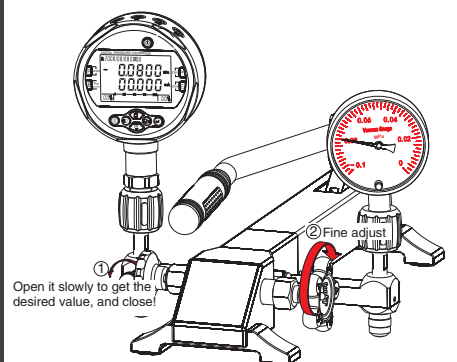

Remark: A: Additel has made a concerted effort to provide complete and current information for the proper use of the equipment. The product specifications and other information contained this manual are subject to change without notice.

B: Above pictures are just for reference.