CHAPTER 1

INTRODUCTION

Congratulations on your purchase of a Labconco CentriVap DNA Concentrator System. Models are available for operation on 115V or 230V.

The CentriVap Concentrator uses centrifugal force with heat and vacuum to rapidly dry precipitates of DNA and RNA samples. Centrifugation eliminates bumping and foaming as vacuum is applied and also concentrates the solute in the bottom of the vial. This allows recovery of solutes from sample volumes as small as a few microliters. The Concentrator is equipped with a 300 watt heater to speed evaporation by warming the chamber during processing. A timed outlet for the vacuum pump connection delays the start of the pump until the rotor reaches operating speed. A safety switch prevents the concentrator from starting when the lid is in the open position and a latch prevents the lid from being opened while the rotor is turning. The compact, low profile design allows the Concentrator to be placed on a bench top or other laboratory work surface.

All wetted parts within the pump are either Teflon®*, Teflon coated or stainless steel. A glass trap is provided to remove liquid from the system before it enters the pump and a second glass trap is provided on the outlet side of the pump to trap liquid expelled from the pump.

*Teflon® is a registered trademark of DuPont

The microprocessor which controls the operation of the heater and the motor provides excellent regulation and reproducibility of protocols. The end of the run can be signaled by a manually preset timer. Nine different protocols can be stored in memory so exact test parameters can be easily repeated.

About This Manual

This manual is designed to help you learn how to install, use, and maintain your CentriVap. Instructions for performing routine maintenance and making minor modifications to your CentriVap are also included.

Chapter 1: Introduction provides a brief overview of the CentriVap, explains the organization of the manual, and defines the typographical conventions used in the manual.

Chapter 2: Prerequisites explains what you need to do to prepare your site before you install your CentriVap. Electrical and exhaust requirements are discussed.

Chapter 3: Getting Started contains the information you need to properly unpack, inspect and install your CentriVap.

Chapter 4: Using Your CentriVap discusses the basic operation of your CentriVap. Information on how to arrange the samples inside your CentriVap and select an operating cycle is included.

Chapter 5: Maintaining Your CentriVap explains how to perform routine maintenance on your CentriVap.

Chapter 6: Modifying Your CentriVap describes how to install the optional glass lid.

Chapter 7: Troubleshooting contains a table of problems you may encounter while using your CentriVap, including the probable causes of the problems, and suggested corrective actions.

Appendix A: CentriVap Components contains labeled diagrams of the components of the CentriVap.

Appendix B: CentriVap Dimensions contains comprehensive diagrams showing the dimensions for the CentriVap.

Appendix C: CentriVap Specifications contains product specifications. Wiring diagrams for both the 115V and 230V CentriVap are also included.

Appendix D: CentriVap Accessories lists the part numbers and descriptions of all of the accessories available for your CentriVap.

Typographical Conventions

Recognizing the following typographical conventions will help you understand and use this manual:

- Book, chapter, and section titles are shown in italic type (e.g., *Chapter 3: Getting Started*).
- Steps required to perform a task are presented in a numbered format.
- Comments located in the margins provide suggestions, reminders, and references.
- Critical information is presented in boldface type in paragraphs that are preceded by the exclamation icon. Failure to comply with the information following an exclamation icon may result in injury to the user or permanent damage to your CentriVap.
- Important information is presented in capitalized type in paragraphs that are preceded by the pointer icon. It is imperative that the information contained in these paragraphs be thoroughly read and understood by the user.



Your Next Step

If your CentriVap needs to be installed, proceed to *Chapter 2: Prerequisites* to ensure your installation site meets all of the requirements. Then, go to *Chapter 3: Getting Started* for instructions on how to install your CentriVap and make all of the necessary connections.

For information on the operational characteristics of your CentriVap, go to *Chapter 4: Using Your CentriVap*.

If your CentriVap is installed and you need to perform routine maintenance on the CentriVap, proceed to *Chapter 5: Maintaining Your CentriVap*.

For information on making modifications to the configuration of your CentriVap go to *Chapter 6: Modifying Your CentriVap*.

Refer to *Chapter 7: Troubleshooting* if you are experiencing problems with your CentriVap.

CHAPTER 2

PREREQUISITES

Before you install your CentriVap, you need to prepare your site for installation. Carefully examine the location where you intend to install your CentriVap. You must be certain that the area is level and of solid construction. In addition, an exhaust means must be provided. An electrical source must be located near the installation site.

Carefully read this chapter to learn:

- the electrical supply requirements.
- the exhaust requirements.

Refer to *Appendix C: CentriVap Specifications* for complete CentriVap electrical and environmental conditions, specifications and requirements.



The CentriVap has not been evaluated by an approval agency for the use of biological, radiotoxins or flammable liquids or materials.

Electrical Requirements

A dedicated grounded electrical outlet is required. This outlet requires a 15 Amp circuit breaker or fuse for models rated at 115V (60 Hz). An 8 Amp circuit breaker or fuse is required for models rated at 230V

(50/60 Hz). 115V models are equipped with a 15 Amp NEMA 5-15P plug. 230V models are not equipped with a plug. It will be necessary to install a plug to match the available receptacle.

It is recommended that an emergency switch for disconnecting the mains in the case of a malfunction be located remote from the CentriVap, preferably outside the room in which the CentriVap is housed, or adjacent to the exit from that room.

Location and Exhaust Requirements

The CentriVap DNA System should be located within a fume hood if hazardous or flammable solvents are used. In all cases, regardless of the solvent used, it is strongly recommended that the vacuum pump is vented in a fume hood. An optional accessory secondary trap is available to minimize the exhausting of solvents into the atmosphere. This does not, however, negate the need to exhaust the vacuum pump into a fume hood.

Space Requirements

Refer to *Appendix C: CentriVap Specifications* for dimensional drawings of the CentriVap.

Your Next Step

After you have determined that the location for your CentriVap accommodates the installation and operational requirements, you are ready to unpack and install your CentriVap. Proceed to *Chapter 3: Getting Started*.

CHAPTER 3

GETTING STARTED

Now that the site for your CentriVap is properly prepared, you are ready to unpack, inspect, install, and test your CentriVap. Read this chapter to learn how to:

- unpack and move your CentriVap.
- set up your CentriVap.
- connect the electrical supply source to your CentriVap.
- properly exhaust your CentriVap.
- safely use solvents with your CentriVap.



The CentriVap weighs over 69 lbs. (31 Kg). The carton allows for lifting with a mechanical lift truck or hand truck. If you must lift the CentriVap manually, use at least two (2) persons and follow safe lifting guidelines.

Unpacking Your CentriVap

The United States Interstate Commerce Commission rules require that claims be filed with the delivery carrier within fifteen (15) days of delivery.

Carefully unpack your CentriVap and inspect it for damage that may have occurred in transit. If your CentriVap is damaged, notify the delivery carrier immediately and retain the entire shipment intact for inspection by the carrier.



DO NOT RETURN GOODS WITHOUT THE PRIOR AUTHORIZATION OF LABCONCO. UNAUTHORIZED RETURNS WILL NOT BE ACCEPTED.



IF YOUR CENTRIVAP WAS DAMAGED IN TRANSIT, YOU MUST FILE A CLAIM DIRECTLY WITH THE FREIGHT CARRIER. LABCONCO CORPORATION AND ITS DEALERS ARE NOT RESPONSIBLE FOR SHIPPING DAMAGE.

Do not discard the carton or packing material for your CentriVap until you have checked all of the components and installed and tested the CentriVap.

CentriVap Components

As previously mentioned, the CentriVap DNA System is available in 115V or 230V. Locate the model of CentriVap you received in the following table. Verify that the components listed are present and undamaged.

Catalog #	Product Description
79700-00	DNA Concentrator – 115V
79700-01	DNA Concentrator – 230V

Plus the Following:

Part #	Component Description
74572-00	User's Manual
13345-00	Power Cord – 115V or
13341-00	Power Cord – 230V
74629-00	Rotor

If you do not receive one or more of the components listed for your CentriVap, or if any of the components are damaged, contact Labconco Corporation immediately for further instructions.

Setting Up Your CentriVap

After you verify receipt of the proper components, move your CentriVap to the level and sturdy location where you want to install it. There is no need to secure the CentriVap DNA System to the work surface. Then, follow the steps listed below.

Emergency Access Into the Chamber

The CentriVap is designed to prevent access to the chamber in the event of a power disruption. If it is necessary to open the lid when there is no electrical power connected to the CentriVap, insert a small screwdriver or similar instrument into the small round hole on the left side of the case near the top behind the control panel. This will unlock the lid latch mechanism. While holding the screwdriver in place, raise the lid with the other hand.



Never attempt to defeat the latch or open the lid while the CentriVap is running.

Exhaust Port

If the CentriVap is not located in a fume hood, attach one end of a .50 inch inside diameter hose to the exhaust port on the left side on the vacuum pump glass trap exhaust port. Clamp securely. Route the other end to a fume hood or other laboratory ventilation device.

Electrical Connection

Plug the power cord into the receptacle on the back of the CentriVap and plug the other end into a suitable power receptacle.

Rotor Installation

Place the rotor onto the shaft of the Concentrator. Rotate the rotor slightly to engage the drive pin in the shaft with the slots in the rotor hub. The top of the shaft should be in line with the top of the rotor hub.



Do not use a rotor if it shows any signs of damage.



Solvent Safety Precautions

The CentriVap is not classified as “explosion proof.” It has been designed with safety as a primary consideration and should be used in a prudent manner using “good laboratory practices.” It has been designed for use with compounds as described in the United States National Electrical Code Class I, Group D. The heater may be programmed to run as hot as 100°C, however, the heater element may normally run at 110°C. A thermal fuse limits the heater to a maximum temperature of 141°C. It is important

that the solvents used are compatible with these temperatures. Do not evaporate solvents that have an autoignition temperature below 180°C. Do not evaporate solvents that are classified as Group A, B, or C by the National Electrical Code. Evaporate only non-flammable or Group D solvents with autoignition temperatures 180°C or above. Use of other compounds could cause an explosion.

Solvents used in the CentriVap may be flammable or hazardous. Use extreme caution and keep sources of ignition away from the solvents. When using flammable or hazardous solvents, both the CentriVap and the vacuum pump should be operated inside a fume hood.

If a sample is spilled in the chamber it must immediately be cleaned up. Hazardous materials such as strong acids or bases, radioactive substances and volatile organics, must be handled carefully and promptly cleaned up if spilled.

Do not store flammable or hazardous solvents within 12 inches (300 mm) of the CentriVap.

Several components of the CentriVap which are located inside the chamber are made of stainless steel which can be attacked by acids. Use of acids such as trifluoroacetic acid can result in degradation of the product and the vacuum pump if the vacuum system is being used. Use care when using aggressive liquids which can damage the CentriVap and thoroughly clean

the CentriVap after each use. Contact Labconco before evaporating acids.

WARNING: The disposal of substances used in connection with this equipment may be governed by various Federal, State or local regulations. All users of this equipment are urged to become familiar with any regulations that apply in the user's area concerning the dumping of waste materials in or upon water, land or air and to comply with such regulations.

Your Next Step

The installation and setup of your CentriVap is now complete. To learn how to load and operate your CentriVap, proceed to *Chapter 4: Using Your CentriVap*. To make a modification to the configuration of your CentriVap, proceed to *Chapter 6: Modifying your CentriVap*. To perform additional diagnostics on your CentriVap, proceed to *Chapter 7: Troubleshooting*. To learn about the maintenance requirements for your CentriVap, proceed to *Chapter 5: Maintaining Your CentriVap*.

CHAPTER 4

USING YOUR

CENTRIVAP

After your CentriVap has been installed as detailed in *Chapter 3: Getting Started*, you are ready to begin using your CentriVap. Read this chapter to learn how to:

- set operating parameters.
- operate the controls.
- properly select and position glassware inside your CentriVap.
- understand the display.
- interrupt a cycle after it has begun.



Do not use the CentriVap in a manner not specified by the manufacturer (refer to *Appendix C: CentriVap Specifications*). The electrical protection properties of the CentriVap may be impaired if the CentriVap is used inappropriately.

Do not store or stack supplies or equipment on top of the CentriVap.

Planning

Thoroughly understand procedures and the equipment operation prior to beginning work. The unique performance of the CentriVap is dependent upon the proper balance of heat, vacuum and centrifugal force. If the proper balance is not established, it is possible to damage or lose a portion of the sample. Therefore, if you are unfamiliar with the CentriVap or are attempting a new protocol, it may be helpful to make a trial run that is void of the sample you are attempting to concentrate.

Glassware Selection

Normally, sample tubes should be filled no more than approximately half full. Select the size of the sample tube so it is compatible with the rotor and the desired sample size. Tubes should not be loose in the rotor. Rotors are available with holes for various size tubes. Refer to *Appendix D: CentriVap Accessories* for available rotor sizes and pages 19 and 20 for recommended usable tube volumes.

Loading Glassware Into the CentriVap

Smooth operation of the CentriVap is dependent upon proper balance of the machine. Therefore, if less than a full load of samples is run, it is important to load samples into the CentriVap in a fairly symmetrical manner distributing the weight of the samples evenly in the sample rotor.

Heat Setting Guidelines

The evaporation rate achieved by the CentriVap is dependent upon a variety of factors. These include the nature of the solvent, the temperature and the pressure in the vacuum system.

As a general guideline, to speed the evaporation process, the CentriVap temperature should be set as high as possible as long as the temperature will not damage the sample or cause the sample to bump.

Time Setting Guidelines

The CentriVap Concentrator has two timers. The “RUN TIME” turns the entire concentrator off after the user set period of time. This stops the rotation, turns off the heater and vacuum pump and bleeds vacuum from the system. The heater may be turned off prior to the concentrator turning off so heat sensitive samples may be protected from exposure to excessive heat after the solvent has evaporated. To turn the heater off prior to stopping the entire system, enter a set time into the memory at the “HEATER TIME”. When the programmed time expires, the heater will turn off but the rotation and vacuum will continue until the run time expires.

The tables in *Appendix C: CentriVap Specifications* indicate approximate times required to evaporate various common solvents. Actual times must be determined by the user. The CentriVap can be set to alarm after a preset period of operation. When the time expires, the CentriVap will give an audible alarm and turn itself off.

CentriVap Controls

The control panel for the CentriVap is shown below with a description about its function.

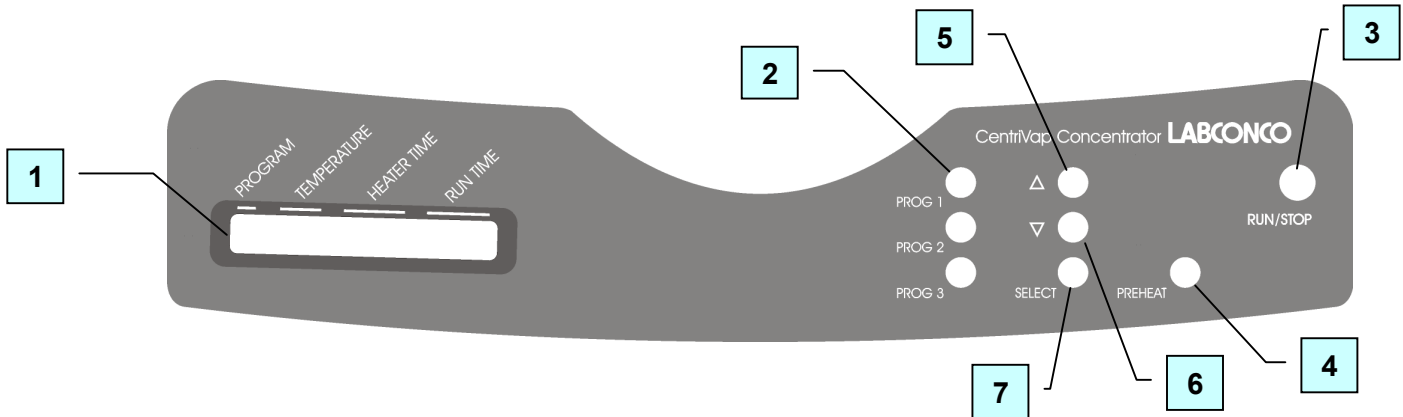

1. Display – The liquid crystal display (LCD) shows set point parameters and actual measured conditions.
2. Program Buttons – Used to initiate the start of a run with the use of just one button.
3. Run/Stop Button – Used to start or stop a run.
4. Preheat Button – Used to turn on the heater to preheat the chamber prior to loading samples.
5. Increase Button – When pressed, the last selected set point will increase.
6. Decrease Button – When pressed, the last selected set point will decrease.
7. Set Point Select Button – To select a parameter to change, press the select button. Arrows on the display will point to the parameter that may be altered.

Operating The CentriVap Controls

Preheat:

To preheat the chamber, press the “PREHEAT” button. The display will show:

SP: XXX ACT: XXX

Press the increase or decrease button until the desired set point (SP) is displayed. The actual chamber temperature, (ACT) is displayed to the right. When power is being supplied to the heaters, a bar under the actual temperature will illuminate. The chamber will continue to preheat until either the “PREHEAT” button is pressed again or the “RUN” button is pressed.

Select existing program:

Operating parameters can be stored in memory so protocols can be repeated. Nine programs can be stored. To select a program, press the set point “SELECT” button until arrows point to the program number indicating that this set point can be run or altered. To change the program number, press the increase or decrease button until the desired program number is displayed. When the program number is changed, all its set points change also to indicate the last entered parameters for that program.

Store frequently run protocols in program 1, 2, or 3. Then, by pressing “PROG 1”, “PROG 2” or “PROG 3”, the stored program will be initiated without having to press any other button. Pressing just the one button starts the rotor, the heater, the timers and the vacuum pump.

Change heat set point:

To change the heat set point, press the set point “SELECT” button until arrows point to the temperature set point which can be changed from -- (OFF) up to 99° by pressing the increase or decrease buttons. The set point is 100°C if the display shows “HI.” The last entered set point is stored in memory.

Change run time or heater time set point:

To change the time set point, press the set point “SELECT” button until arrows point to the run time set point which can be changed from 1 to 999 minutes by pressing the increase or decrease buttons. If it is desired to have the CentriVap run continuously without alarming at the end of a time period, press the increase

button until the display says “ON.” The last entered set point is stored in memory.

If during a run the “STOP” button is pressed, the timers remember the time at which stop occurred. If “RUN” is then pressed, the timers continue to count down from the time at which they were stopped. If you are running program 1, program 2 or program 3, pressing “PROG 1”, “PROG 2” or “PROG 3” resets the timers to the original set point time and the CentriVap starts a new run.

To reset the timers to the original set point time when running programs other than program 1, program 2 or program 3, use the “SELECT” button to select the program display and change the program.

Operating The CentriVap



Never lift the lid if the rotor is moving.

Never attempt to reach into the chamber if the rotor is moving.

Never attempt to defeat the lid latch mechanism.

Do not operate the CentriVap if the lid is scratched or nicked, or shows signs of damage.

Never lean on the CentriVap when it is operating.

1. Select a program or set the set point parameters.
2. Preheat the chamber if desired.
3. Place samples in vials. Normally the vials should be no more than half full. Place vials in a rotor.
4. Load the rotor with samples into the chamber.
5. Close the lid.

6. Press “RUN.” If the display was showing set point parameters, it will change to show actual parameters. Press “RUN” again. The “S” (STOP) in the display changes to “R” (RUN). The program on the display alternately displays “R” or the number of the program that is running. If you intend to run program 1, 2 or 3, simply press “PROG 1”, “PROG 2” or “PROG 3” to quick start the CentriVap.
7. Set point parameters can be altered at any time during a run by first selecting the parameter using the set point “SELECT” button and then pressing the “INCREASE” or “DECREASE” switch.
8. If the time set point is used, at the end of the set time an alarm sounds. All functions cease.
9. Press “STOP” to terminate operation if the CentriVap has not already stopped itself.
10. When the evaporation is complete, allow the rotor to stop moving, lift the lid and remove the samples.

Operational Notes

The LCD display conveys various pieces of information. When the CentriVap is turned on, the CentriVap returns to the same mode (“RUN” or “STOP”) that it was in when the power was turned off. If the CentriVap was in the “RUN” mode when the power was turned off, when the power is turned on, the CentriVap attempts to return to the programmed set points and continue the run.

To reset the timers to the original set point when running programs other than program 1, program 2 or program 3, press the start button and hold it for five seconds. The display will indicate that the timer is reset.

Interrupting a Cycle After it Has Begun

At any time during a run, the cycle may be stopped by pressing the “STOP” button. This shuts off all operating functions. After the rotor stops, the lid may

be opened. If it is necessary to re-start the CentriVap, close the lid and press “RUN.” The CentriVap resumes operation at the same set point parameters and the timer continues to count down from the time at which the CentriVap was stopped.

CHAPTER 5

MAINTAINING YOUR

CENTRIVAP

Under normal operation, the CentriVap requires little maintenance. The following maintenance schedule is recommended:

As needed:

1. Clean up all spills; remove liquids from the chamber. Clean or decontaminate all surfaces using agents suitable for the substances spilled.
2. Clean lid and gasket using soft cloth, sponge or chamois and a mild, non-abrasive soap or detergent.
3. At the end of a run, liquid collected in the glass traps should be removed. To empty a trap, unscrew the glass bowl from the head. Dispose of the liquid in accordance with all codes. Reinstall the glass bowl by screwing it back on to the head.
4. If the media in the optional clear canister has changed color, discard and replace the insert with a new insert. For the radiochemical trap insert, no indicator exists; therefore, it should be discarded after each use. In radioactive applications, the system should be monitored with a Geiger counter.

Daily:

1. To prolong the life of the DNA vacuum pump and to optimize its performance, it is important to purge all liquid from within it. When the DNA concentration process is completed, open the CentriVap lid and push the rotor switch ON. In ten seconds, the pump will operate and will draw air through the system. The rotor will not turn with the lid open. The length of the liquid purge time is dependent on the volatility of the solvents used. Use of water may require an overnight purge time.

Monthly:

1. The rubber components on the CentriVap may eventually deteriorate and require replacement. The effective life of rubber parts depends upon both their usage and the surrounding environment. Check all rubber hoses and gaskets and replace any that show signs of hardening, permanent set or deterioration.
2. Using a soft cloth, sponge or chamois and a mild, non-abrasive soap or detergent, clean the glass lid.
3. Using a soft cloth, sponge, or chamois and a mild, non-abrasive soap or detergent, clean the exterior surfaces of the unit. Liquid spray cleaners and polishes may be used on the exterior surfaces. Do not use solvents to remove stains from the exterior surfaces as they may damage the finish.

CHAPTER 6

MODIFYING YOUR

CENTRIVAP

The configuration of your CentriVap can be changed to accommodate your needs. If the solvents used in the CentriVap degrade the acrylic lid it may be replaced with an optional glass lid to gain added chemical resistance. You may wish to add a secondary trap to trap vapors exhausted from the vacuum pump. To observe the samples while they are processing, an optional strobe light may be installed. Read this chapter to learn how to:

- install a glass lid
- install a chemical trap.
- install a CentriZap™ strobe.

Installing a Glass Lid

Turn off the CentriVap. Unplug the power cord from the wall receptacle. Pull outward on the hinge pin knob. Lift and remove the old lid. To install the new lid, reverse the process.

Installing a Secondary Chemical Trap

An accessory secondary chemical trap is available to minimize the exhausting of solvents into the atmosphere. Attach the bracket to the LH side of the housing using the screws provided. Attach the hose from the outlet on the vacuum pump to the “out” connector of the canister housing. Unscrew the clear bowl of the canister housing from the head. Remove both the upper and lower caps from the filter cartridge and insert the small end of the cartridge into the hole in the center of the head. Reinstall the clear bowl.

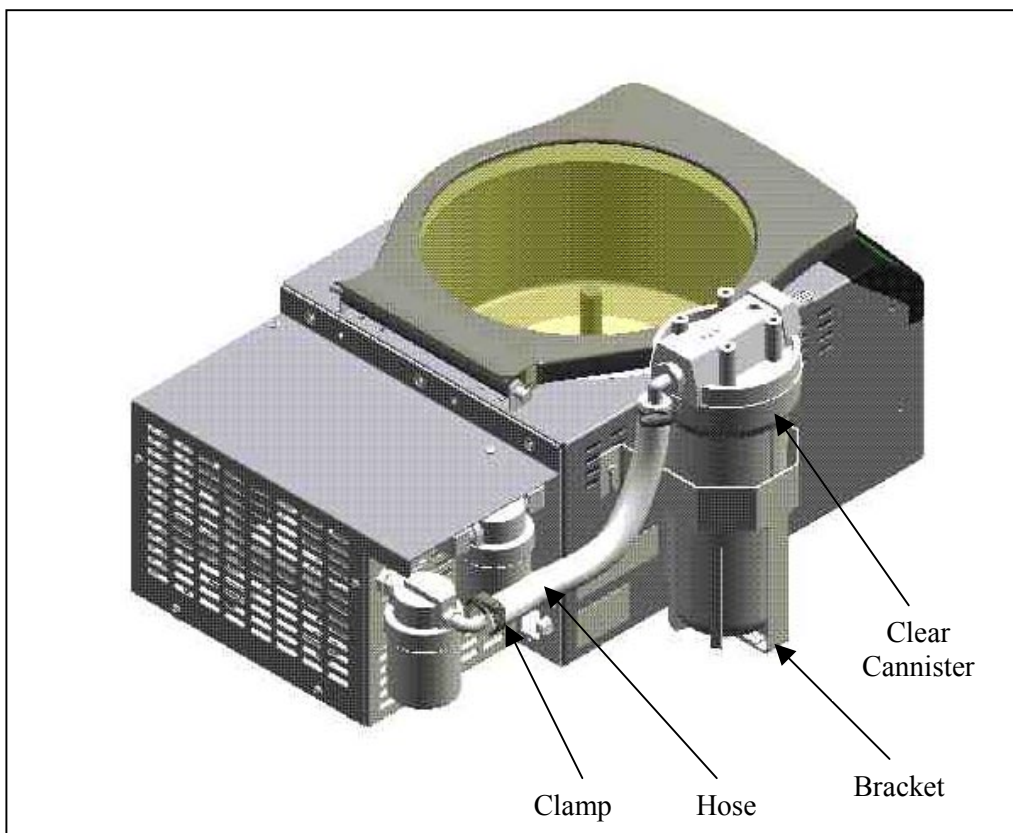

Be sure to use the proper cartridge for your application. The moisture cartridge is used to trap water vapor. The acid cartridge is used to trap acid vapors. The solvent cartridge is used to trap solvent vapors and the radiochemical cartridge is used to trap radioactive waste.

When the media in the insert has changed color, discard the insert and replace it with a new insert. For the radiochemical trap insert, no color indicator exists, therefore it should be discarded after each use. Use a Geiger counter to monitor the pump exhaust.



THIS RADIOCHEMICAL
CARTRIDGE DOES NOT MEET
NRC FILTER DESIGN
RECOMMENDATIONS.

AFTER OPERATING, PROPERLY
DISPOSE OF ALL HAZARDOUS
MATERIALS IN COMPLIANCE
WITH ALL APPLICABLE CODES.
LABCONCO IS NOT RESPONSIBLE
FOR IMPROPER DISPOSAL OF ANY
MATERIALS.

Installing a CentriZap™ Strobe Light

An accessory strobe light is available to enable you to see the samples as they are rotating in the rotor. Attach the holder to the right hand side of the CentriVap using the screws provided. Plug the connector on the strobe light harness into the receptacle on the back of the CentriVap marked “STROBE OUTLET.” Peel the protective backing off the enclosed Velcro® and attach it to the back of the vacuum pump housing. Secure the power supply box on the harness to the Velcro. Place the light in the holder.

To use the strobe light while the CentriVap is operating, remove the light from its holder, press the trigger and shine the light on the samples in the rotor.

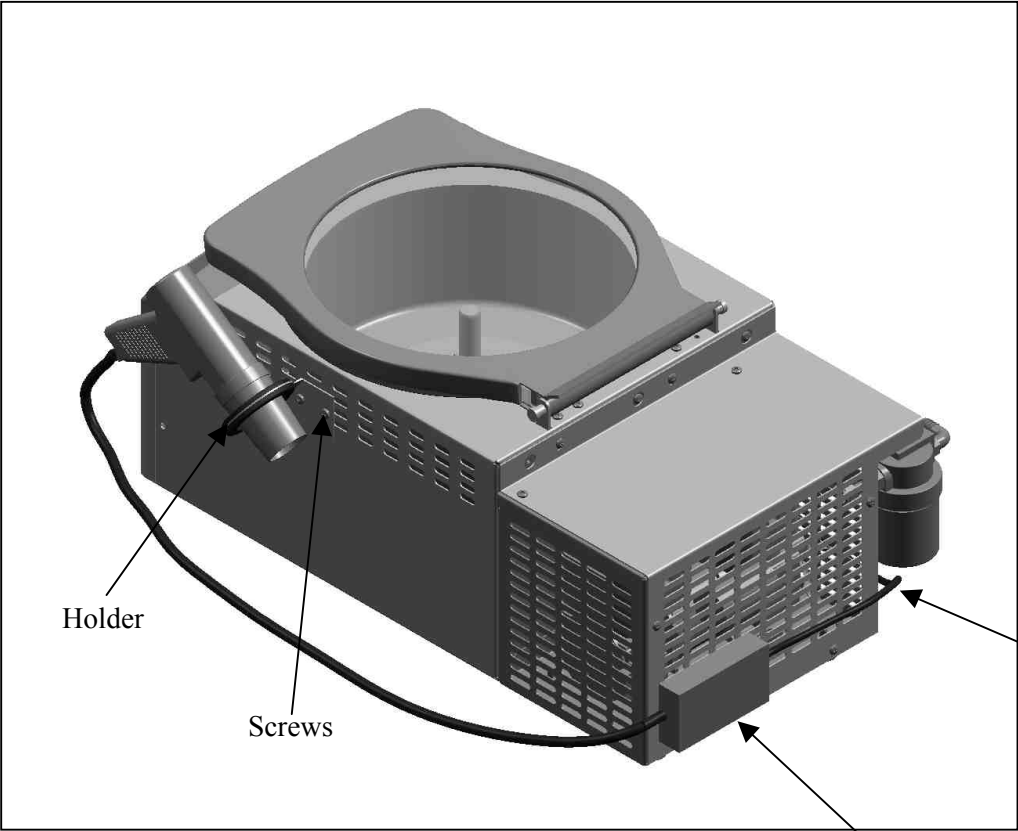

Holder

Screws

Plug wire into
"Strobe" receptacle

Box secured
with Velcro

CHAPTER 7

TROUBLESHOOTING

Refer to the following if your CentriVap fails to operate properly. If the suggested corrective actions do not solve your problem, contact Labconco for additional assistance. The following failure codes may appear on the display when problems are sensed by the internal self check routine.

DISPLAY ERROR CODE	CAUSE	CORRECTIVE ACTION
HEAT SENSOR	Sensor failure	Replace sensor assembly.
	Connection failure	Repair connection.
CLOSE LID	Lid open	Close lid.
LATCH FAIL	Solenoid failure	Check component.
	Switch or sensor failure	Check connections.
MEM FAIL P1	Memory failure	Push program button #1
	New memory IC chip	Push program button #1.
	Bad memory IC chip	Call Labconco – Replace IC chip or control PCB.
MOTOR ERROR	Defective motor	Replace motor.
	Hall effect sensor failure	Replace sensor.
	Wire failure	Repair wire.

Other corrective actions for potential problems are as follows:

PROBLEM	CAUSE	CORRECTIVE ACTION
Unit will not operate	Unit not connected to electrical power	Connect unit to proper electrical receptacle.
	Circuit breaker blown	Correct electrical problem and reset circuit breaker by pressing button.
	Lid open	Close lid.
Excessive vibration	Sample tubes not located symmetrically in rotor	Reposition sample tubes.
Sample odor in lab	Vent hose exhausting into lab area	Redirect hose to fume hood.
Evaporation rate is reduced	Heater inoperable	Contact Labconco.
	Vacuum pump failure	Check pump.
No vacuum poor vacuum	Pump not on	Turn on pump.
	Liquid in glass trap	Empty trap.
	Control valve open	Check control valve.
	Leaks in lines or connectors or gasket	Locate and repair.
	Foreign material on lid gasket	Clean gasket and lid.

APPENDIX A

CENTRIVAP

COMPONENTS

The following pages list components that are available for your CentriVap. The parts shown are the most common replacement parts. If other parts are required, contact Product Service.

CentriVap Components

Item	Quantity	Part No.	Description
1	1	7459000	Motor w/Capacitor
2	1	7481700	Valve, Vacuum Break (115V)
2A	1	7481701	Valve, Vacuum Break (230V)
3	1	7453500	Heater (115V)
3A	1	7453501	Heater (230V)
4	1	1647106	O-Ring, Outer
5	1	1647105	O-Ring, Inner
6	1	7975902	Fuse, High Temp Limiter
7	1	7456000	Harness, Temp & Speed Sensor
8	1	7479400	PCB
9	1	1289200	Relay (115V)
9A	1	1289100	Relay (230V)
10	1	7826000	Switch, Latch
11	1	7478700	Solenoid, Latch
12	1	7403701	Display
13	1	7455300	Label/Switch Pad
14	1	7452600	Gasket, Lid
15	1	7452500	Lid, Acrylic
16	42.2 inch	7451700	Extrusion
17	2	7452200	Hinge, Bracket Assembly
18	1	1289300	Circuit Breaker (115V)
18A	2	1289308	Circuit Breaker (230V)
19	1	7450400	Vacuum Pump (115V)
19A	1	7450401	Vacuum Pump (230V)
20	2	7450200	Jar, Trap
20A	2	7450300	Gasket, Jar, Trap
Not Shown	1	1334500	Power Cord (115V)
Not Shown	1	1334100	Power Cord (230V)

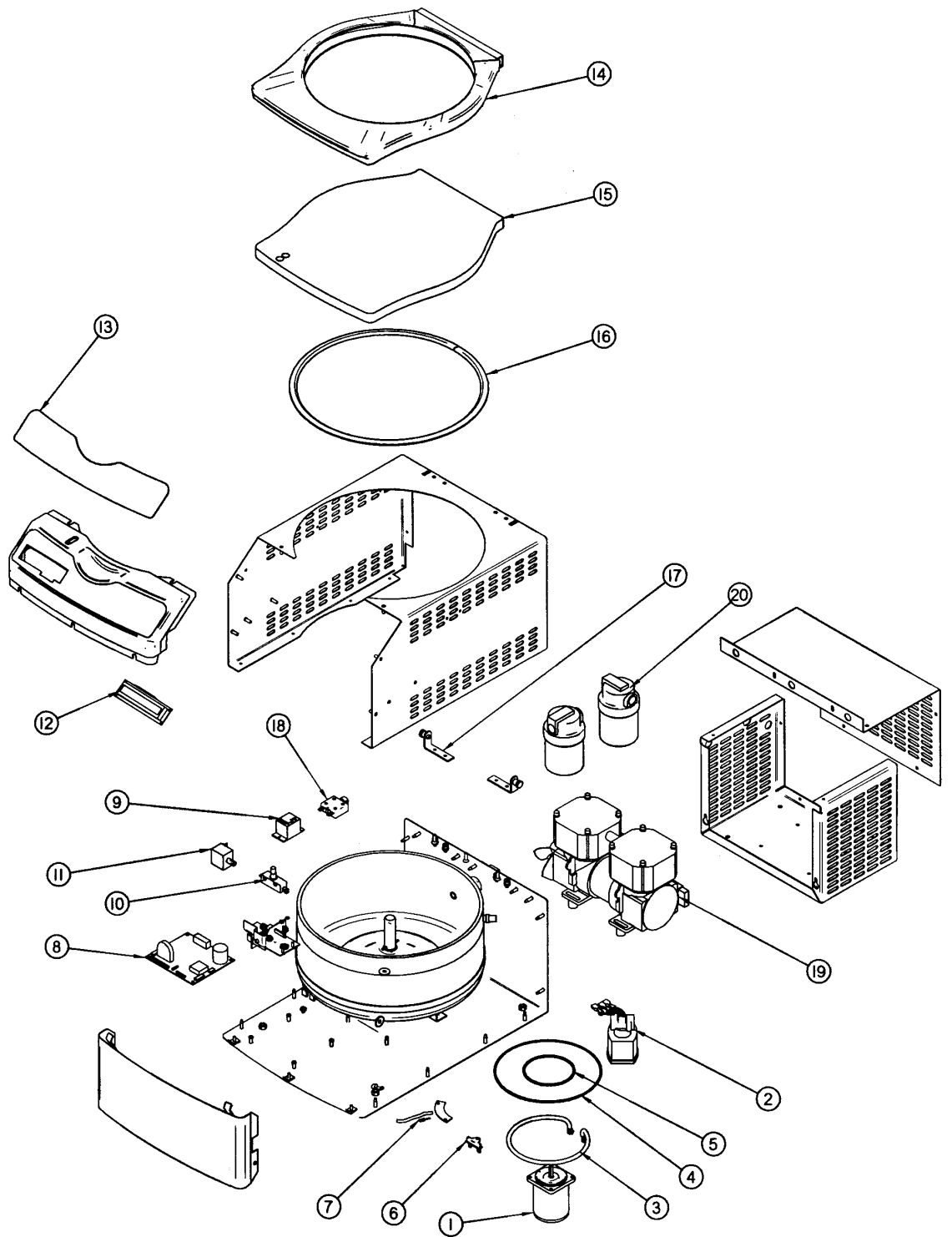

APPENDIX B

CENTRIVAP

DIMENSIONS

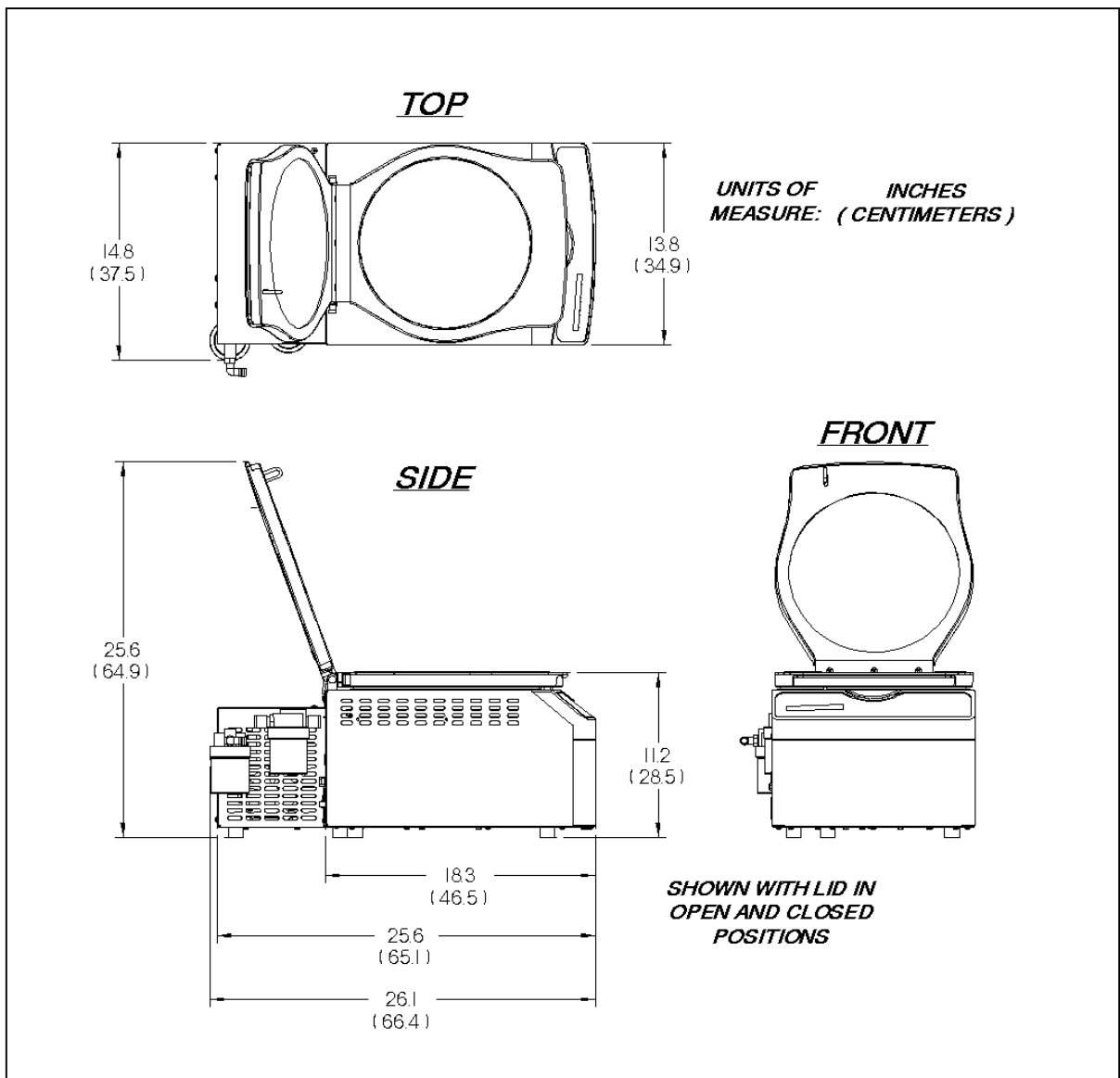

APPENDIX C

CENTRIVAP

SPECIFICATIONS

This Appendix contains technical information about the CentriVap including specifications, environmental operating conditions, wiring diagrams and evaporation rates.

Electrical Specifications

- Nominal amperage for 115V CentriVap (model 79700-00) (including vacuum pumps): 5.5A
- Nominal amperage for 230V CentriVap (model 79700-01) (including vacuum pumps): 2.8A
- Frequency (all models): 50/60 Hz
- Phase: Single
- Heater power: 300 watts

Environmental Conditions

- Indoor use only.
- Maximum altitude: 6562 feet (2000 meters).
- Ambient temperature range: 41° to 104°F (5° to 40°C).
- Maximum relative humidity: 80% for temperatures up to 88°F (31°C), decreasing linearly to 50% relative humidity at 104°F (40°C).
- Main supply voltage fluctuations not to exceed $\pm 10\%$ of the nominal voltage.
- Transient overvoltages according to Installation Categories II (Overvoltage Categories per IEC 1010). Temporary voltage spikes on the AC input

line that may be as high as 1500V for 115V models and 2500V for 230V models are allowed.

- Used in an environment of Pollution degrees 2 (i.e., where normally only non-conductive atmospheres are present). Occasionally, however, a temporary conductivity caused by condensation must be expected, in accordance with IEC 664.

Wiring Diagram (115V Model)

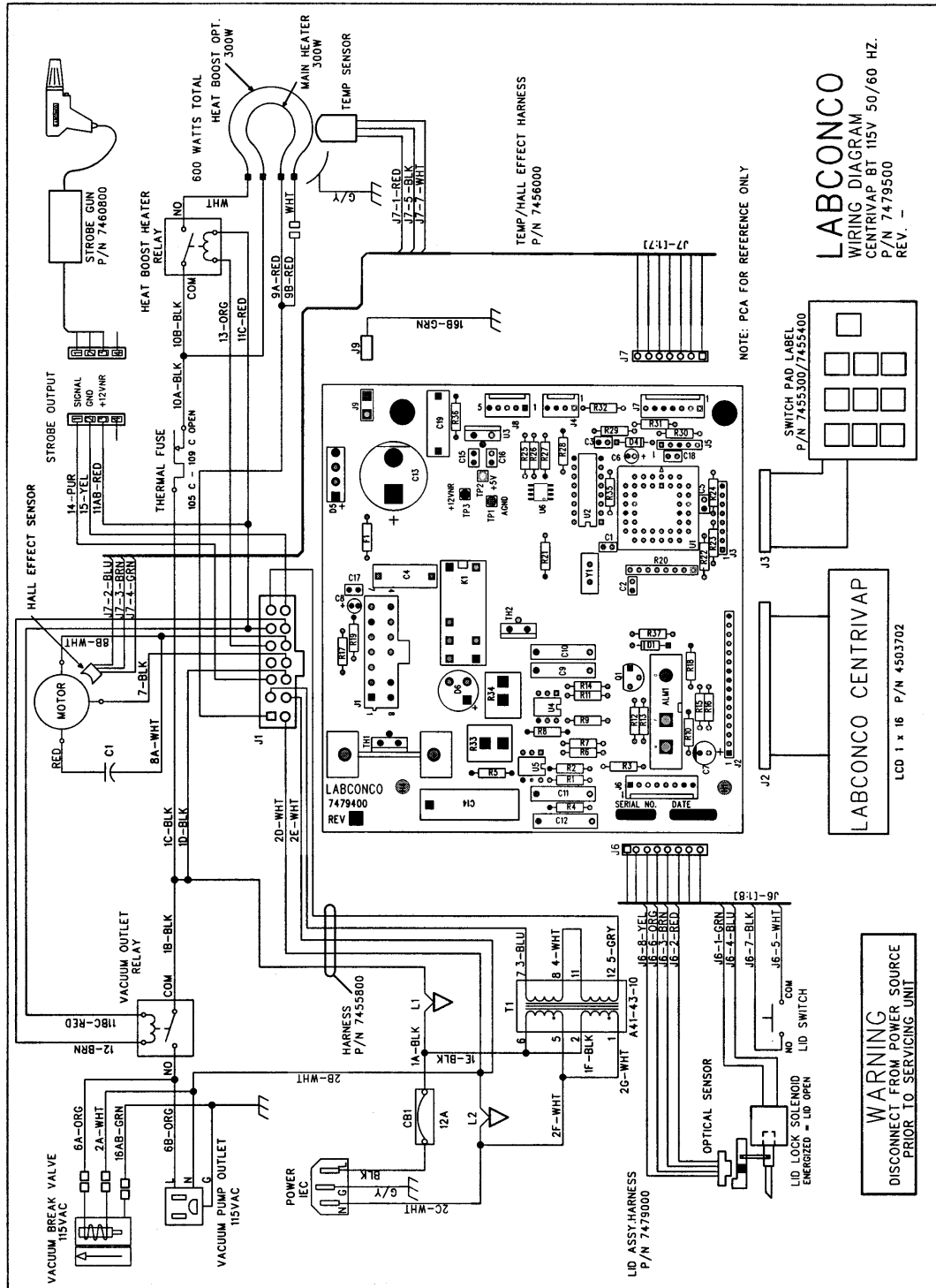

Evaporation Rates

	Tube Size (ml)	Number of Samples	Sample Size (ml)	Heater Temp (C)	Time to Dry (min)	Rate Overall (ml/min)
Methylene Chloride	50	12	25	45	80	3.75
	15	18	10	45	45	4.00
Toluene	50	12	25	45	204	1.47
	50	12	25	100	96	3.13
	15	18	10	45	119	1.51
	15	18	10	100	42	4.29
Acetonitrile	50	12	25	45	184	1.63
	50	12	25	100	81	3.70
	15	18	10	45	106	1.70
	15	18	10	100	52	3.46
	1.5	132	1	45	55	2.40
	1.5	90	1	45	47	1.92
	1.5	132	1	60	37	3.57
	1.5	132	1	75	33	5.74
Methanol	50	12	25	45	233	1.29
	15	18	10	45	141	1.28
	1.5	132	1	35	88	1.50
	1.5	132	1	45	64	2.06
	1.5	132	1	60	50	2.64
	1.5	90	1	75	38	2.37
	1.5	132	1	75	39	3.38
	1.5	132	1	100	25	5.28
Water	50	12	25	45	1397	0.21
	50	12	25	100	445	0.67
	15	18	10	45	841	0.19
	1.5	132	1	45	427	0.30
	1.5	132	1	60	303	0.44
	1.5	132	1	75	196	0.67
	1.5	132	1	100	117	1.13

APPENDIX D

CENTRIVAP

ACCESSORIES

The following accessories are available for the CentriVap DNA System.

PART #	DESCRIPTION
74609-00	Clear Canister
78148-00	Acid Trap Insert
78149-00	Moisture Trap Insert
78150-00	Radiochemical Trap Insert
78152-00	Solvent Trap Insert
74566-01	Glass Lid for Concentrator
74643-00	Strobe Light
74619-00	Rotor – Microtiter 96 Well Plate

Declaration of Conformity

Application Council Directive(s): 73/23/EEC, 89/336/EEC

Standard(s) to which conformity is declared: EN60950, EN55014, EN55104

Manufacturer's Name: Labconco Corporation

Manufacturer's Address: 8811 Prospect Avenue
Kansas City, MO 64132 USA

Importer's Name: See Shipping/Customs Documents*

Importer's Address: See Shipping/Customs Documents for your equipment

Type of Equipment: Laboratory Equipment - Sample Concentration

Model No.: Centrivap DNA System 79700-01
Centrivap Benchtop Concentrator 78100-01, 78100-03
Centrivap Cold Trap 78110-01, 74600-01
Centrivap Mobile Console 78120-01, 78120-03

Serial No.: Various - See Individual Declaration

Year of Manufacture: 2000 and Subsequent

I, the undersigned, hereby declare that the equipment specified above conforms to the above Directive(s) and Standard(s).

See individual Declaration of Conformity which will be signed by the importer for your country.

Place:

(Signature)

Date:

(Full Name)

(Position)

*An individual version of this declaration is included with your shipping/customs documentation.

Labconco P/N 36960-04 Rev A