

Sartorius Economy Series Sartorius Express Series

Industrial
Weighing Technology

EA and EB Models
Electronic Precision Scales
Installation and Operating Instructions

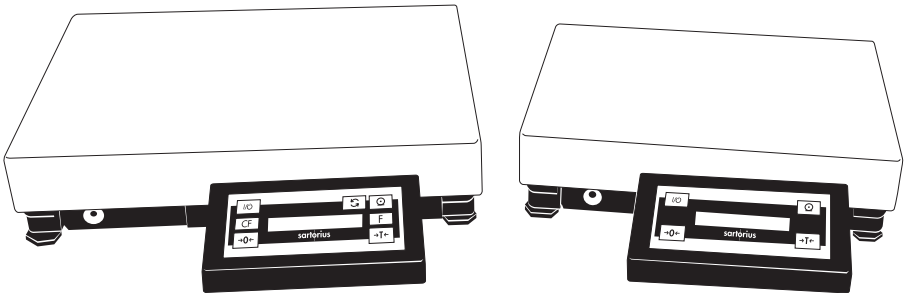

sartorius

Intended Use

The Economy/Express Series from Sartorius offers precision scales for weighing, with capacities ranging from 0.1 g to 150 kg.

Economy/Express scales meet the highest requirements on the accuracy and reliability of weighing results through the following features:

- Efficient filtering-out of unfavorable ambient conditions, such as vibrations, drafts etc.
- Stable and reproducible results
- Excellent readability under any lighting conditions
- Rugged, durable weighing system
 - Type of scale housing protection
 - The weighing platforms are IP54-protected
 - The display and control units are IP40-protected

Economy/Express scales save work and speed up simple routine applications through:

- Ultrafast response times
- Easy operation
- Computer connectivity through a built-in RS-232 interface
- Two lines in the printout are configurable to show, e.g., your company name

Additional Features of the EB Models:

With the EB model, you can choose from the following extra functions for simple applications:

- Counting
- Toggling between weight units (second weight unit)
- Net-total formulation (tare memory)
- Second tare memory (incl. automatic container taring function)
- Weighing in percent (incl. display of the difference between current weight and stored reference weight)
- Averaging
- Calculation by a factor
- Totalizing
- Gross/net toggling

Note to Users in the U.S.

This equipment has been tested and found to comply with the limits for a Class A digital device, pursuant to Part 15 of the FCC Rules. These limits are designed to provide reasonable protection against harmful interference when the equipment is operated in a commercial environment. This equipment generates, uses, and can radiate radio frequency energy and, if not installed and used in accordance with the instruction manual, may cause harmful interference to radio communications.

Operation of this equipment in a residential area is likely to cause harmful interference in which case the user will be required to correct the interference at his own expense. Changes or modifications not expressly approved by Sartorius AG could void the user's authority to operate the equipment.

Contents

Intended Use	2
Contents	3
Warnings and Safety Precautions	4
Operating Design	5
Getting Started	10
Operating the Scale	
Basic Weighing Function	14
Calibration/Adjustment	17
Application Programs in the EB Models	
Counting	20
Toggle between Weight Units	23
Second Tare Memory	27
Weighing in Percent	30
Calculation by a Factor	33
Totalizing	36
Gross/Net Toggling	39
Averaging	41
Data Output Functions	45
Data Interface	50
Pin Assignment Chart	59
Cabling Diagram	60
Configuring the Scale (Menu)	
Setting Parameters in the Operating Menu	61
Scale Operating Menu (Overview)	64
Error Codes	68
Care and Maintenance	70
Instructions for Recycling	71
Overview	
General View of the Scale	72
Description of the Keys	73
Specifications	74
Dimensions (Scale Drawings)	79
Accessories (Options)	80
Information on EC Verification	82
Declarations of Conformity	85
EC Type Approval	88
Index	89

Warnings and Safety Precautions

This scale has been constructed in accordance with the European Directives as well as international regulations and standards for operation of electrical equipment, electromagnetic compatibility, and stipulated safety requirements. Improper use or handling, however, can result in damage and/or injury.

Read these operating instructions thoroughly before using your scale to prevent damage to the equipment. Keep these instructions in a safe place.

Follow the instructions below to ensure safe and trouble-free operation of your scale:

- ⚠ Do not use this scale in a hazardous area/location
- ⚠ Make sure that the voltage rating printed on the AC adapter is identical to your local line voltage
- The only way to turn the power off completely is to disconnect the AC adapter
- The scale housing is IP54-protected against dust deposits and water splashes
- The display and control unit is IP40-protected against penetration of solid foreign objects
- Connect only Sartorius accessories and options, as these are optimally designed for use with your Economy/Express scale
- Protect the AC adapter and the display and control unit from contact with liquids

When cleaning your scale, make sure that no liquids enters the scale housing; use only a slightly moistened cloth to clean the scale.

Do not open the scale housing. If the seal is broken, this will result in forfeiture of all claims under the manufacturer's warranty.

In case you have any problems with your scale:

- Contact your local Sartorius office, dealer or service center

Operating Design

The scales in the Economy/Express Series consist of a weighing cell and a display and control unit. In addition to the choice of power supply (via AC adapter or external rechargeable battery pack), your scale also has an interface port for connecting peripheral devices, such as a printer, computer, universal remote control switch, etc.

The display and control unit is affixed to the weighing platform. Operation of the Economy scales is simple and uniform.

The EB models include all the features of the EA models plus application programs for toggling between weight units, counting, weighing in percent, etc.

Where not expressly stated otherwise, the information contained here also applies to the verified model versions in the European Union and European Economic Area (indicated by the "...-LOCE" suffix to the model name).

Keys

The Economy/Express Series scales can be operated using either the keys on the display and control unit or a connected computer (PC).

Some of the keys activate different functions, depending on how long they are pressed ("press briefly" = < 2 sec.; "press and hold" = ≥ 2 sec.).

The equipment supplied includes adhesive labels printed in different languages for identifying the functions assigned to the keys.

EA Model

The EA model has 4 keys. The function activated by each key will differ according to whether the scale is in the weighing mode or setup mode.

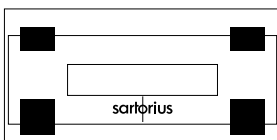

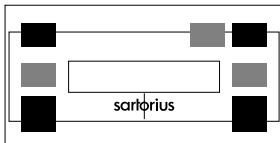

EB Model

The EB model has 3 additional keys (gray), for controlling the application programs.

Display

The display is divided into 5 sections:

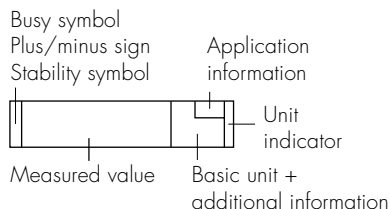

Busy Symbol, Plus/Minus Sign, Stability Symbol

If the symbol displayed here is

- a triangle ▲, this indicates that the scale is performing a function (busy symbol)
- a plus or minus sign (+ or –), this applies to the value displayed (on the EB models, this also applies to calculated values; e.g., during counting)
- a small "o", this indicates that the verified scale has been zeroed/tared
- a flashing triangle ▼, this indicates that the calculated values are not valid for legal metrology

Measured Value

When the scale is in the weighing mode, the weight is displayed here. In the setup mode, the menu code numbers are shown here.

On EB models, calculated values and application parameter settings are also displayed here.

Basic Unit and Additional Information

When the scale has stabilized, the weight unit is displayed here (g or kg). On the EB model, the calculated values (e.g., % or pcs) are also displayed.

Application Information

On EB models, this section shows information concerning the current application program; e.g., the reference quantity for counting.

Unit Indicator

You can affix one of several adhesive overlays to the right of this section. These overlays show the optional weight units selected in the scale Setup menu. The arrows indicate the selected units.

Input Functions

When the scale is in the setup mode, you can select parameters from lists. The lists are contained in a menu, which is divided into 3 levels.



To set parameters: Turn the scale off and back on again. While all segments are displayed, press $\boxed{\rightarrow T \leftarrow}$ /[TARE] briefly.

To navigate within a menu level: Press $\boxed{\rightarrow T \leftarrow}$ /[TARE] briefly; when you reach the last menu item, the first is shown again.

To change menu levels: Press $\boxed{\odot}$ /[PRINT] briefly.

To confirm the selected parameters on all 3 levels: Press and hold the $\boxed{\odot}$ /[PRINT] key.

“o” indicates the selected parameter option.

All parameter options are listed in detail under “Configuring the Scale.”

To store parameter settings and exit the menu:
Press and hold the /[TARE] key
Parameter settings are stored in the non-volatile memory. When you turn on the scale, the last parameters used are active.

To exit the menu without storing any new settings:
Press /[ON/OFF]

Output Functions

Your Economy/Express scale is equipped with a data interface for connecting your choice of the following:

- Printer
- PC
- Universal remote control switch

Printer

You can configure a variety of options for data output to a printer.

You can have a printout generated automatically or only when the /[PRINT] key is pressed. You can make the print function dependent on or independent of stability parameters, and define whether data ID codes will be included in the printout or not.

The print functions are described in detail under “Data Output Functions” in the chapter entitled “Operating the Scale.”

Data Interface

Instead of a printer, you can connect a different peripheral device, such as a computer, to the data interface.

You can use a connected computer to control the Economy/Express scale. Communication between the scale's data interface and a PC is in the form of request and response messages. Not all request messages will activate response messages.

See "Data Output Functions" in the chapter entitled "Operating the Scale" for a detailed description.

Error Messages

Error messages are displayed for 2 seconds. The format is as follows:

- Sequence error: "E" + 2 digits
- Hardware error: "E" + 3 digits

The section entitled "Error Messages" contains detailed information.

Getting Started

Warranty

Do not miss out on the benefits of our full warranty. Complete the warranty registration card, indicating the date of installation, and return the card to your Sartorius office or dealer.

Storage and Shipping Conditions

Do not expose the scale to shocks, vibrations, moisture or extreme temperatures.

Unpacking the Scale

- After unpacking the scale, check it immediately for any visible damage as a result of rough handling during shipment.
- Note:
The display and control unit is attached to the weighing platform via a cable.
- If you see any sign of damage, proceed as directed in the chapter entitled "Care and Maintenance," under the section on "Safety Inspection."

Save the box and all parts of the packaging until you have successfully installed your scale. Only the original packaging provides the best protection for shipment. Before packing your scale, unplug all connected cables to prevent damage.

Equipment Supplied

The equipment supplied includes the components listed below:

- Scale with attached display and control unit
- Load pan
- AC adapter
- Installation and operating instructions

Installation Instructions

The Sartorius Economy/Express scales are designed to provide reliable weighing results under normal ambient conditions. When choosing a location to set up your scale, observe the following so that you will be able to work with added speed and accuracy:

- Set up the scale on a stable, even surface
- Avoid placing the scale in close proximity to a heater or otherwise exposing the scale to heat or direct sunlight
- Protect the scale from drafts that come from open windows or doors
- Avoid exposing the scale to extreme vibrations during weighing
- Protect the scale from aggressive chemical vapors
- Do not expose the scale to extreme moisture over long periods

Conditioning the Scale:

Moisture in the air can condense on the surfaces of a cold scale whenever it is brought into a substantially warmer place. If you transfer the scale to a warmer area, make sure to condition it for about 2 hours at room temperature, leaving it unplugged from AC power. Afterwards, keep the scale continuously connected to AC power.

Seal on Scales Verified for Use in Legal Metrology in the EU*:

EU legislation requires that a control seal be affixed to the verified scale. The control seal consists of a sticker with the “Sartorius” logo. This seal will be irreparably damaged if you attempt to remove it. If the seal is broken, the validity of the verification will become void, and you must have your scale re-verified.

* including the Signatories of the Agreement on the European Economic Area

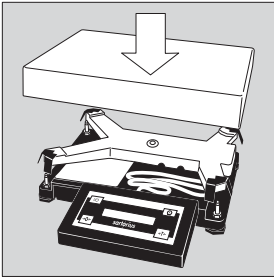

- Place the load plate on the scale

EA/EB...DCE/EDE:

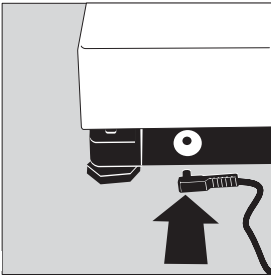

Connecting the Scale to AC Power

- Check the voltage rating and the plug design
 - If they do not match the rating or standard you use, contact your Sartorius office or dealer

Use only

- Original Sartorius AC adapters
- AC adapters with a registered approval rating from a national testing laboratory

EA/EB...FEG:

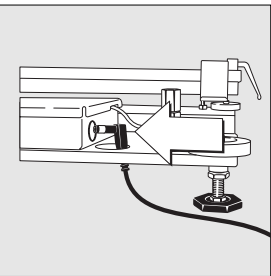

- See the chapter entitled "Accessories" for information on using an external rechargeable battery pack with your scale
- Insert the right-angle plug into the jack and then tighten the screws
- Then insert the plug of the AC adapter into a wall outlet (mains)

Safety Precautions

The AC adapter rated to Class 2 can be plugged into any wall outlet without requiring any additional safety precautions. The pole of the output voltage is connected to the scale housing, which can be grounded for operation. The data interface is also electrically connected to the scale housing (ground).

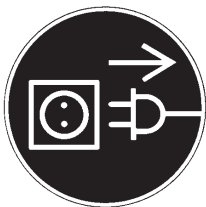

Connecting Electronic Peripheral Devices

- Make absolutely sure to unplug the scale from AC power before you connect or disconnect a peripheral device (printer or PC) to or from the interface port.

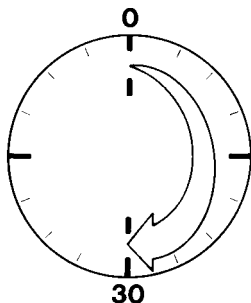

Warmup Time

To deliver exact results, the scale must warm up for at least 30 minutes after initial connection to AC power. Only after this time will the scale have reached the required operating temperature.

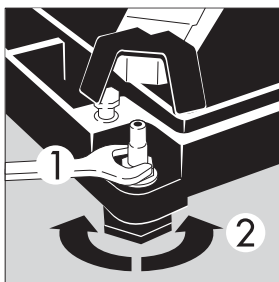

Leveling the Scale

- Remove the load plate
- Loosen the lock nuts on all leveling feet (use a 13 mm open-end wrench if necessary)
- Turn the leveling feet until the scale is level
- Avoid unintentional changes in the adjustment: Tighten the lock nuts with an open-end wrench and then replace the load plate

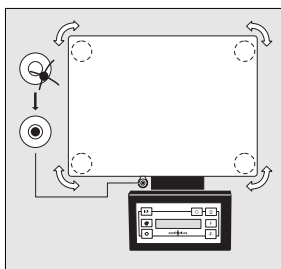

Leveling the Scale (for EA/EB...-I, ...-LOCE models only)

- Using the 4 footscrews, level the scale so that the air bubble is centered within the level indicator

Operating the Scale

Basic Weighing Function

Purpose

The basic weighing function is always accessible in the EA and EB scales.

In the EB model, this function can be used alone or in combination with an application program (Toggle between Weight Units, Counting, Weighing in Percent, etc.).

Features

- Zeroing the scale
Depending on prevailing ambient conditions, the display may not show a zero readout even though there is no load on the scale. If the weight shown is less than 2% of the scale's maximum weighing capacity, you can zero the scale.
- Taring the scale
Tare the scale with an empty container on the weighing pan to obtain a readout of the net weight after the container is filled.
- Printing weights

Factory Settings

Weight unit 1: Kilogram (1 7 3)

Manual/automatic printing:



Manual after stability (6 1 2)

Print format:

Gross, tare and net values with data ID codes (7 1 3)



Preparation

- Turn on the scale: Press /[ON/OFF]
- > All segments light up briefly
- To change configurations: See the chapter entitled "Configuring the Scale"
- To load factory-set configurations: See "Configuring the Scale," parameter **9 - 1**
- > The  symbol is displayed when the scale is zeroed or tared (only on scales verified for use in legal metrology)







Additional Functions in EB models:

- Start an application
- Toggle the display between weight and calculated value
- Delete an application

Practical Examples

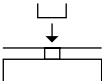
Simple weighing

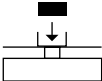
Menu code settings: Factory-set codes

Step	Key (or instruction)	Display/Output
1. Turn on the scale	 /[ON/OFF]	0.000 kg
2. If necessary, zero the scale ( symbol: scale is zeroed – verified scales only)	 /[ZERO]	0.000 kg
3. Place the container on the scale (here: 0.015 kg)		+ 0.015 kg
4. Tare the scale	 /[TARE]	0.000 kg
5. Place a sample in the container on the scale (here: 0.125 kg)		+ 0.125 kg
6. Print weight*	 /[PRINT]	<p>EISENMUELLER GOETTINGEN</p> <p>N + 0.125 kg T + 0.015 kg G# + 0.140 kg</p>

* The Sartorius Service Center or your Sartorius dealer can configure the scale to include 2 customer-specific lines on the printout. Software is available for setting this configuration with a PC.

Calibration/Adjustment

Purpose

Calibration is the determination of the difference between the weight readout and the true weight (mass) of a sample. Calibration does not entail making any changes within the scale. Adjustment is the correction of this difference between the measured value displayed and the true weight (mass) of the sample, or the reduction of the difference to an allowable level within the maximum permissible error limits.

Features

External adjustment can only be performed when

- there is no load on the scale,
- the scale is set to zero, and
- the internal signal is stable.

If these conditions are not met, an error message is displayed.

The weight on the scale must not differ from the nominal weight by more than 2%.

You can use g, kg or lb as the weight unit for calibration (**14**)

You can block calibration of the scale (**15**)

Calibration/Adjustment for Verified Scales

- The calibration function is blocked in verified scales (sealed switch cover)
- > You can only perform calibration by removing this seal. In this case, verification is no longer valid and you must have your scale re-verified.

Factory Settings





Weight unit for calibration: kg (**142**)

Calibration function: accessible (**151**)

Example

Calibrate the scale

Menu code settings: Factory-set codes

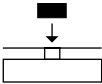
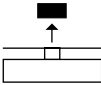
Step	Key (or instruction)	Display/Output
1. Turn on the scale	 /[ON/OFF]	0.000 kg
2. If necessary, zero the scale ( symbol: scale is zeroed – verified scales only)	 /[ZERO]	0.000 kg
3. Begin calibration Calibration weight is displayed without wt. unit	 /[TARE] > 2 sec.	+ 5.000
4. Place the indicated calibration weight on the scale (here: 5,000 g)		5.000
After calibration, the calibration weight is displayed with wt. unit		+ 5.000 kg
5. Remove the calibration weight		0.000 kg

Application Programs (EB Models Only)

Note Concerning Verified Scales Used as Legal Measuring Instruments in the EU*:

All application programs can also be used in legal metrology. Calculated weight values are indicated by one of the following symbols, displayed to the right of the numerical value:

- Percentage = %
- Piece count = pcs
- Other calculated value = o

A flashing triangle ▼ displayed to the left of the numerical value indicates the value is not valid for legal metrology (e.g., in averaging or calculation).

* including the Signatories of the Agreement on the European Economic Area

Counting (EB Models Only)

Purpose

With the Counting program you can determine the number of parts that have approximately the same average piece weight.

Available Features

- The reference sample quantity can be changed either in the operating menu or during weighing
- Store the current weight value to have it loaded as the preset reference sample quantity the next time you initialize the Counting application
- Re-initialize without quitting the program
- The average piece weight is automatically output via the data interface port after initialization, if the menu code for "Printout with data ID codes" is set
- Press /[TOGGLE] to toggle the display between piece count and weight



Factory Settings

Display accuracy 2: Standard resolution (3 2 !)

Reference sample quantity: 10 (3 3 2)

Preparation

Configure the Counting application in the operating menu:

- If the scale is on, turn it off:
Press /[ON/OFF]
- Turn on the scale: Press /[ON/OFF]; while all segments are lit, press /[TARE]



- Select the "Counting" menu item:
Press $\rightarrow T \leftarrow$ /[TARE], \odot /[PRINT],
and \odot /[PRINT]; press $\rightarrow T \leftarrow$ /[TARE] repeatedly,
if necessary
2 1 4 Counting

- Confirm the selection of Counting:
Press \odot /[PRINT] for > 2 sec.

> o indicates that this is the current menu code setting

- Set the next parameters: Press \odot /[PRINT]

- Select and confirm:

- Reference sample quantity:

3 3 1 5 pcs

3 3 2 10 pcs

3 3 3 20 pcs

3 3 4 50 pcs

3 3 5 100 pcs

see also the "Scale Operating Menu (Overview)" in the chapter entitled "Configuring the Scale"

- Save settings and exit the Setup menu:
Press $\rightarrow T \leftarrow$ /[TARE] for at least 2 sec.

Additional Functions

In addition to the basic functions (power off, zeroing, taring and printing), you can also access the following functions from this application:

- Initialize application (\boxed{F} key)
- Delete initialization values (\boxed{CF} key)
- Change reference sample quantity after deleting initialization value ($\boxed{\text{S}}$ /[TOGGLE] key, press for at least 2 sec.)
- Display weight ($\boxed{\text{S}}$ /[TOGGLE] key)
- Calibrate/adjust scale ($\rightarrow T \leftarrow$ /[TARE], press for at least 2 sec.)

Example

Determine an unknown piece count; store the weight on the scale as a reference sample quantity

Settings (changes in the factory settings required for this example):

Menu: Application program: Counting (2 14)

Step	Key (or instruction)	Display/Output
1. Turn on the scale	/[ON/OFF]	
2. If necessary, zero the scale (symbol on the left: verified scale is zeroed)	/[ZERO]	0.000 kg ^{ID}
3. Select the reference sample quantity (here: 50 pcs)	/[TOGGLE] /[TOGGLE]	rEF 20 (briefly) rEF 50 (briefly)
4. Place the reference sample quantity (50 pcs) on the scale (here: 0.930 kg)	 	+ 0.930 kg ⁵⁰
5. Start the application; if the print format is set to include data ID codes, the following is printed	F	+ 50 pcs ⁵⁰ wRef + 0.186 kg
6. Display weight	/[TOGGLE]	+ 0.930 kg ⁵⁰
7. Display quantity	/[TOGGLE]	+ 50 pcs ⁵⁰
8. Weigh uncounted parts (here: 174 pcs)	 	+ 174 pcs ⁵⁰
9. Print total piece count	/[PRINT]	EISENMUELLER GOETTINGEN Qnt + 174 pcs
10. Unload the scale	 	0 pcs ⁵⁰
11. Repeat the procedure starting from Step 8, if desired.		

Toggle between Weight Units (EB Models only)

Purpose

With this application program you can toggle the display of a weight value back and forth between two weight units.

Available Features

- Toggling the displayed weight
- Other features as for the basic weighing function

Factory Settings

Weight unit 1: kg (1 7 3)

Weight unit 2: kg (3 1 3)







Preparation

Configure the Toggle weight units application in the operating menu:

- If the scale is on, turn it off:

Press /[ON/OFF]







- Turn on the scale: Press /[ON/OFF]; while all segments are lit, press /[TARE]
 - Select the “Toggle weight units” menu item: Press /[TARE], /[PRINT], and /[PRINT]; press /[TARE] repeatedly, if necessary
2 1 2 Toggle weight units
 - Confirm selection: Press /[PRINT] for at least 2 sec.
- > o indicates that this is the current menu code setting

- Set the next parameters: Press /[PRINT]
- Select and confirm:
 - Weight unit 1: see next page (1 7 x)
 - Display resolution 1:
 - ! 8 ! Standard resolution
 - ! 8 2 10x higher resolution**
 - ! 8 3 2x higher resolution (PolyRange)*
 - Weight unit 2: see next page (3 1 x)
 - Display resolution 2:
 - 3 2 ! Standard resolution
 - 3 2 2 10x higher resolution**
 - 3 2 3 2x higher resolution (PolyRange)*





see also the "Scale Operating Menu (Overview)" in the chapter entitled "Configuring the Scale"
- Save settings and exit the Setup menu: Press /[TARE] for at least 2 sec.

Additional Functions

In addition to the functions for:

- power off (/[ON/OFF] key),
- zeroing (/[ZERO] key),
- taring (/[TARE] key), and
- printing (/[PRINT] key),

you can also access the following functions from this application:

- toggle between weight units/and 2 (/[TOGGLE] /[PRINT] or  key),
- calibration/adjustment (/[TARE] key; press for at least 2 sec.)

* = not applicable for verified balances

** = only for EB...-OUR models

You can affix one of several adhesive overlays to the right of this section. These overlays show the optional weight units selected in the scale Setup menu. The arrows indicate the selected units.

These settings cannot be changed on verified scales.

Menu code	Unit	Conversion factor	Printout
(172) (312)	Grams	1.000000000000	g
(173) (313)	Kilograms	0.001000000000	kg
(174) (314)	Carats	5.000000000000	ct
(175) (315)	Pounds	0.00220462260	lb
(176) (316)	Ounces	0.03527396200	oz
(177) (317)	Troy ounces	0.03215074700	ozt
(178) (318)	Hong Kong tael	0.02671725000	tlh
(179) (319)	Singapore tael	0.02645544638	tls
(1710) (3110)	Taiwanese tael	0.02666666000	tlt
(1711) (3111)	Grains	15.43235835000	GN
(1712) (3112)	Pennyweights	0.64301493100	dwt
(1713) (3113)	Milligrams	1000.00000000000	mg
(1714) (3114)	Parts per pound	1.12876677120	/lb
(1715) (3115)	Chinese tael	0.02645547175	tlc
(1716) (3116)	Mommes	0.26670000000	mom
(1717) (3117)	Austrian carats	5.00000000000	K
(1718) (3118)	Tola	0.08573333810	tol
(1719) (3119)	Baht	0.06578947437	bat
(1720) (3120)	Mesghal	0.21700000000	MS
(1721) (3121)	Tons	0.00000100000	T
(1722) (3122)	lb/oz	0.03527396200	o

If you select menu code 1722 or 3122, you can affix the label with the “lb” weight unit under the left number, and the label with the “oz” weight unit under the number on the right.









Example

Toggle the display from kilograms [kg] (1st unit) to pounds [lb] (2nd unit)

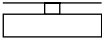
Settings (changes in the factory settings required for this example):

Menu: Application program: Toggle between weight units (2 12)

Menu: Weight unit 2: pounds (3 15)

Step	Key (or instruction)	Display/Output
1. Turn on the scale	 /[ON/OFF]	
2. Place weight on scale (here: 2.295 kg)	 	+ 2.295 kg 
3. Toggle to weight unit 2: Pounds [lb]	 /[TOGGLE]	+ 5.060 
4. Print weight	 /[PRINT]	EISENMUELLER GOETTINGEN G + 5.060 lb
5. Toggle to weight unit 1: kilograms [kg]	 /[TOGGLE]	+ 2.295 kg 

Second Tare Memory (EB Models Only)

Purpose

With this application program you can store the weight on the scale as a tare compensation weight.

Available Features

- Press **[F]** to store the weight on the scale in the second tare memory
- *NET* is displayed next to the net weight readout if the scale has been tared or if a tare value is stored in the second tare memory (**N** in the printout indicates that the scale was tared by pressing the **[→T←]/[TARE]** key; **N1** indicates that there is data in the second tare memory)
- You can have a series of containers tared in sequence, if the scale is unloaded to under 30% of the previous weight after measurement and then loaded with 70% – 130% of the previous weight (i.e., the next container)
- Press **[CF]** to delete the value from the second tare memory
- Press **[↺]/[TOGGLE]** to toggle between weight unit 1 and weight unit 2

Preparation

Configure the Second tare memory application in the operating menu:

- If the scale is on, turn it off:
Press **[I/O]/[ON/OFF]**
- Turn on the scale: Press **[I/O]/[ON/OFF]**; while all segments are lit, press **[→T←]/[TARE]**



- Select the “Second tare memory” menu item:
Press $\boxed{\rightarrow T \leftarrow}$ /[TARE], $\boxed{\odot}$ /[PRINT], and $\boxed{\odot}$ /[PRINT]; press $\boxed{\rightarrow T \leftarrow}$ /[TARE] repeatedly, if necessary
 $2 \ 1 \ 3$ Second tare memory
 $2 \ 1 \ 10$ Second tare memory with automatic container taring
- Confirm selection of Second tare memory:
Press $\boxed{\odot}$ /[PRINT] for at least 2 sec.
- > \odot indicates that this is the current menu code setting
- Set the next parameters: Press $\boxed{\odot}$ /[PRINT]
- Select and confirm:
 - Weight unit 1: (see also “Toggle between Weight Units”)
 $1 \ 7 \ 2$ Grams
 ...
 $1 \ 7 \ 22$ lb/oz
 - Weight unit 2: (see also “Toggle between Weight Units”)
 $3 \ 1 \ 2$ Grams
 ...
 $3 \ 1 \ 22$ lb/oz

see also the “Scale Operating Menu (Overview)” in the chapter entitled “Configuring the Scale”
- Save settings and exit the Setup menu:
Press $\boxed{\rightarrow T \leftarrow}$ /[TARE] for at least 2 sec.

Additional Functions

In addition to the basic functions (power off, zeroing, taring and printing), you can also access the following functions from this application:

- Store weight in second tare memory (\boxed{F} key)
- Delete tare memory (\boxed{CF} key)
- Toggle weight unit (\boxed{S} /[TOGGLE] key)

Example

Fill containers with nearly identical weights ($\pm 30\%$)

Settings (changes in the factory settings required for this example):

Menu: Application program: Second tare memory with automatic container taring (2 | 10)

Menu: Weight unit 2: Grams (3 | 2)

Step	Key (or instruction)	Display/Output
1. Turn on the scale	/[ON/OFF]	
2. If necessary, zero the scale (symbol: scale is zeroed – verified scales only)	/[ZERO]	0.000 kg
3. Place an empty container on the scale (here: 65 g)		+ 0.065 kg
4. Store the container weight in the second tare memory. If the print format is set to include data ID codes, the following is printed	[F]	0.000 kg _{NET} N1 + 0.065 kg
5. Fill the container (here: to 500 g)		+ 0.500 kg _{NET}
6. Display weight unit 2	/[TOGGLE]	+ 500 g _{NET}
7. Display weight unit 1	/[TOGGLE]	+ 0.500 kg _{NET}
8. Remove the filled container from the scale		– 0.065 kg _{NET}
9. Place the next empty container on the scale (here: 75 g)		0.000 kg _{NET} (automatic container taring is performed)
10. Repeat the procedure starting from Step 5.		

Weighing in Percent (EB Models Only)

Purpose

This application program allows you to obtain weight readouts in percent which are in proportion to a reference weight.

Available Features

- Reference percentage can be changed either in the operating menu or during weighing
- Store the current weight value to have it loaded as the preset reference percentage the next time you initialize the Weighing in Percent application
- Optional auto-zero function
- The reference sample weight is automatically output via the data interface port after initialization, if the menu code for “Printout with data ID codes” is set
- Press /[TOGGLE] to toggle the display between percentage and weight



Factory Settings

Display accuracy 2: Standard resolution (3 2 !)

Reference percentage: 10 (3 3 2)

Preparation

Configure the Weighing in Percent application in the operating menu:

- If the scale is on, turn it off:
Press /[ON/OFF]
- Turn on the scale: Press /[ON/OFF]; while all segments are lit, press /[TARE]



- Select the “Weighing in Percent” menu item:
Press $\rightarrow T \leftarrow$ /[TARE], \odot /[PRINT], and
 \odot /[PRINT]; press $\rightarrow T \leftarrow$ /[TARE] repeatedly,
if necessary
2 1 5 Weighing in percent – without taring
2 1 1 1 Weighing in percent – with taring

- Confirm selection of Weighing in Percent:
Press \odot /[PRINT] for at least 2 sec.

> o indicates that this is the current menu code setting

- Set the next parameters: Press \odot /[PRINT]

- Select and confirm:

- Reference percentage at power-on:

3 3 1 5 %
3 3 2 10 %
3 3 3 20 %
3 3 4 50 %
3 3 5 100 %

see also the “Scale Operating Menu (Overview)”
in the chapter entitled “Configuring the Scale”

- Save settings and exit the Setup menu:
Press $\rightarrow T \leftarrow$ /[TARE] for at least 2 sec.

Additional Functions

In addition to the basic functions (power off, zeroing, taring and printing), you can also access the following functions from this application:

- Initialize application (\boxed{F} key)
- Delete initialization values (\boxed{CF} key)
- Change reference percentage after deleting initialization value (\boxed{S} /[TOGGLE] key, press for at least 2 sec.)
- Display weight (\boxed{S} /[TOGGLE] key)
- Calibrate/adjust scale ($\rightarrow T \leftarrow$ /[TARE], press for at least 2 sec.)











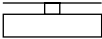

Example

Determine an unknown percentage; store the weight on the scale as a reference percentage

Settings (changes in the factory settings required for this example):

Menu: Application program: Weighing in percent (2 15)

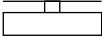
Menu: Reference percentage 100 % (3 3 5)

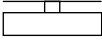
Step	Key (or instruction)	Display/Output
1. Turn on the scale	 /[ON/OFF]	
2. If necessary, zero the scale ( symbol: scale is zeroed – verified scales only)	 /[ZERO]	0.000 kg
3. Place the reference weight on the scale (here: 2.295 kg = 100%)	 ↓ 	+ 2.295 kg
4. Start the application; if the print format is set to include data ID codes, the following is printed	 F	+ 100.00 % Wxx% + 2.295 kg
5. Display weight	 /[TOGGLE]	+ 2.295 kg
6. Display percentage	 /[TOGGLE]	+ 100.00 %
7. Display the reference percentage	 F (at least 2 sec.)	rEF 100
8. Place an unknown weight on the scale (here: 3.225 kg)	 ↓ 	+ 140.41 %
9. Print percentage	 /[PRINT]	Prc + 140.41 %
10. Unload the scale	 ↑ 	0.00 %
11. Repeat the procedure starting with Step 8, if desired.		

Calculation by a Factor (EB Models Only)

Purpose

With this application program you can calculate the weight of a sample by a given factor.

Available Features

- Calculate a weight value using one of the following factors: 0.25; 0.50; 0.75; 1.0; 1.5; 2.0; 2.5; 3.0; 3.5; 4.0; 4.5; 5.0
- A flashing triangle in the display indicates a calculated value
- Press **[CF]** to delete the calculation factor
- Press **[↵]/[TOGGLE]** to toggle between weight unit 1 and weight unit 2

Factory Settings

Weight unit 1: kg (173)

Weight unit 2: kg (313)

Display accuracy 2: Standard resolution (321)

Preparation



Configure the Calculation application in the operating menu:

- If the scale is on, turn it off:

Press **[I/O]/[ON/OFF]**

- Turn on the scale: Press **[I/O]/[ON/OFF]**; while all segments are lit, press **[→T←]/[TARE]**
- Select the "Calculation" menu item: Press **[→T←]/[TARE]**, **[Q]/[PRINT]**, and **[Q]/[PRINT]**; press **[→T←]/[TARE]** repeatedly, if necessary
2 17 Calculation by a factor







- Confirm selection of Calculation:
Press /[PRINT] for at least 2 sec.
- > o indicates that this is the current menu code setting
- Set the next parameters: Press /[PRINT]
- Select and confirm:
 - Weight unit 1: (see also "Toggle between Weight Units")
1 7 2 Grams
... ..
1 7 2 2 lb/oz
 - Weight unit 2: (see also "Toggle between Weight Units")
3 1 2 Grams
... ..
3 1 2 2 lb/oz

see also the "Scale Operating Menu (Overview)" in the chapter entitled "Configuring the Scale"
- Save settings and exit the Setup menu:
Press /[TARE] for at least 2 sec.

Additional Functions

In addition to the basic functions (power off, zeroing, taring and printing), you can also access the following functions from this application:

- Initialize application ( key)
- Change the calculation factor after the application is initialized ( key)
- Delete initialization values ( key)
- Toggle weight unit (/[TOGGLE] key)
- Calibration/adjustment (/[TARE] key; press for at least 2 sec.)

Example

You have a formula requiring several different components for a total amount of 1,000 g. You want to use this recipe to make a 500 g batch (factor: 0.5). The scale shows the amounts called for in the formula, although only half the amounts are placed on the scale. This saves you having to recalculate the amount of each component.

Settings (changes in the factory settings required for this example):

Menu: Application program: Calculation (2 1 7)

Step	Key (or instruction)	Display/Output
1. Turn on the scale	/[ON/OFF]	
2. If necessary, zero the scale (symbol: scale is zeroed – verified scales only)	/[ZERO]	0.000 kg
3. Place an empty container on the scale (here: 65 g)		+ 0.065 kg
4. Tare the scale	/[TARE]	0.000 kg _{NET}
5. Start calculation	[F]	▽ 0.000 kg _{NET} ²⁵
6. Select the calculation factor	[F]	▽ 0.000 kg _{NET} ⁵⁰
7. Add first component (amount called for in the formula: 240 g; actual amount: 120 g)		± 0.240 kg _{NET} ⁵⁰
8. Add other components (until the display indicates 1,000 g)		± 1.000 kg _{NET} ⁵⁰
9. Print weight of components	/[PRINT]	Res + 1.000 kg

Totalizing (EB Models Only)

Purpose

This application program acts as a cumulative memory function.

Available Features

- The current weight is stored as a net value when the scale stabilizes
- A value indicated as negative (–) in the display is stored as a positive (+) value in the totalizing memory
- The data stored in the totalizing memory is automatically output via the data interface port after initialization, if the menu code for “Printout with data ID codes” is set
- The number of values in the totalizing memory is displayed (transaction counter)
- Press **[F]** for > 2 sec. to display the contents of the totalizing memory
- Press **[CF]** to clear the totalizing memory. The total is displayed for 1.5 seconds and printed
- You cannot toggle between weight units when there is data in the totalizing memory

Factory Settings

Weight unit 1: kg (1 7 3)

Display accuracy 2: Standard resolution (3 2 !)



Preparation

Configure the Totalizing application in the operating menu:

- If the scale is on, turn it off:
Press $\boxed{\text{I/O}}$ /[ON/OFF]
 - Turn on the scale: Press $\boxed{\text{I/O}}$ /[ON/OFF]; while all segments are lit, press $\boxed{\rightarrow\text{T}\leftarrow}$ /[TARE]
 - Select the "Totalizing" menu item:
Press $\boxed{\rightarrow\text{T}\leftarrow}$ /[TARE], $\boxed{\text{O}}$ /[PRINT], and $\boxed{\text{O}}$ /[PRINT]; press $\boxed{\rightarrow\text{T}\leftarrow}$ /[TARE] repeatedly, if necessary
 2 18 Totalizing
 - Confirm selection of Totalizing:
Press $\boxed{\text{O}}$ /[PRINT] for at least 2 sec.
- > o indicates that this is the current menu code setting
- Set the next parameters: Press $\boxed{\text{O}}$ /[PRINT]
 - Select and confirm:
 - Weight unit 1: (see also "Toggle between Weight Units")
 1 7 2 Grams
 \dots
 1 7 22 lb/oz

see also the "Scale Operating Menu (Overview)" in the chapter entitled "Configuring the Scale"
 - Save settings and exit the Setup menu:
Press $\boxed{\rightarrow\text{T}\leftarrow}$ /[TARE] for at least 2 sec.

Additional Functions

In addition to the basic functions (power off, zeroing, taring and printing), you can also access the following functions from this application:











- Start application ($\boxed{\text{F}}$ key)
- Display value in totalizing memory ($\boxed{\text{F}}$ key; press for at least 2 sec.)
- Clear totalizing memory ($\boxed{\text{CF}}$ key)

Example

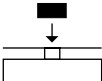
Totalize weight values

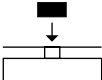
Settings (changes in the factory settings required for this example):

Menu: Application program: Totalizing (2 18)

Step	Key (or instruction)	Display/Output
1. Turn on the scale	 /[ON/OFF]	
2. If necessary, zero the scale ( symbol: scale is zeroed – verified scales only)	 /[ZERO]	0.000 kg
3. Place sample on the scale (here: 380 g)		+ 0.380 kg
4. Store value in memory; if the print format is set to include data ID codes, the following is printed	 F	+ 0.380 kg ¹ G + 0.380 kg
5. Place the next sample on the scale (here: 575 g)		+ 0.575 kg ¹
6. Store value in memory	 F	+ 0.575 kg ²
7. Display the total in memory (total is also printed)	 F for at least 2 sec.	\pm 0.955 kg ² (briefly) Sum + 0.955 kg
8. Clear totalizing memory and print total	 CF	Sum + 0.955 kg
9. Repeat the procedure starting from Step 4, if desired.		

Gross/Net Toggling (EB Models Only)

Purpose

With this application program you can toggle between net and gross values.

Available Features

- Toggle the display between gross and net weights when there is data in the tare memory
- Press /[TOGGLE] to toggle between weight unit 1 and weight unit 2

Factory Settings









Weight unit 1: kg (1 7 3)

Weight unit 2: kg (3 1 3)

Display accuracy 2: Standard resolution (3 2 1)

Preparation

Configure the Gross/net toggling application in the operating menu:

- If the scale is on, turn it off:
Press /[ON/OFF]
 - Turn on the scale: Press /[ON/OFF]; while all segments are lit, press /[TARE] briefly
 - Select the "Gross/net toggling" menu item:
Press /[TARE], /[PRINT], and /[PRINT]; press /[TARE] repeatedly, if necessary
2 1 9 Gross/net toggling
 - Confirm selection of Gross/net toggling:
Press /[PRINT] for at least 2 sec.
- > o indicates that this is the current menu code setting
- Set the next parameters: Press /[PRINT]





- Select and confirm:
 - Weight unit 1: (see also "Toggle between Weight Units")
 - 1 7 2 Grams
 - ...
 - 1 7 2 2 lb/oz
 - Weight unit 2: (see also "Toggle between Weight Units")
 - 3 1 2 Grams
 - ...
 - 3 1 2 2 lb/oz
 - Display accuracy 2:
 - 3 2 1 Standard resolution
 - 3 2 2 10x higher resolution * *
 - 3 2 3 2x higher resolution (PolyRange)*

see also the "Scale Operating Menu (Overview)" in the chapter entitled "Configuring the Scale"
- Save settings and exit the Setup menu:
 - Press /[TARE] for at least 2 sec.

Additional Functions

In addition to the basic functions (power off, zeroing, taring and printing), you can also access the following functions from this application:

- Toggle display between gross and net values ( key)
- Toggle weight unit (/[TOGGLE] key)

Example of Printout

Net display

(/[PRINT] key):

N	+	0.125 kg
T	+	0.015 kg
G#	+	0.140 kg

Gross display

(/[PRINT] key):

G	+	0.140 kg
---	---	----------

* = not applicable for verified scales

** = only for EA/EB...-OUR models

Averaging (EB Models Only)

Purpose

Use this program to determine the weights of unstable samples (e.g., live animals) or to determine weights under unstable ambient conditions. In this program, the scale calculates the weight as the average value from a defined number of individual weighing operations. These weighing operations are also known as “subweighing operations” or “subweighs.”

Available Features

- You can set the number of subweighing operations performed in the operating menu, or before starting the Averaging application (press **[5]**/[TOGGLE])
- The number of subweighs remaining to be performed is indicated in the display during weighing
- The measured result displayed is the arithmetic mean shown in the selected weight unit; a triangle under the plus or minus sign indicates that this is a calculated value
- Press **[F]** for at least 2 sec. to display the pre-set number of subweighing operations
- Press **[5]**/[TOGGLE] to toggle the display between the measured result and the weight
- The measurement result is automatically output via the data interface port after initialization, if the menu code for “Printout with data ID codes” is set

Factory Settings

Display accuracy 2: Standard resolution (3 2 1)

Number of subweighs for averaging: 10 (3 3 2)







Preparation

Configure the Averaging application in the operating menu:





- If the scale is on, turn it off:
Press /[ON/OFF]
 - Turn on the scale: Press /[ON/OFF]; while all segments are lit, press /[TARE]
 - Select the "Averaging" menu item:
Press /[TARE], /[PRINT], and /[PRINT]; press /[TARE] repeatedly, if necessary
2 1 12 Averaging
 - Confirm selection of Averaging: Press /[PRINT] for at least 2 sec.
- > o indicates that this is the current menu code setting
- Set the next parameters: Press /[PRINT]
 - Select and confirm:
 - Number of subweighs for averaging:
 - 3 3 1 5 subweighs
 - 3 3 2 10 subweighs
 - 3 3 3 20 subweighs
 - 3 3 4 50 subweighs
 - 3 3 5 100 subweighs
- see also the "Scale Operating Menu (Overview)" in the chapter entitled "Configuring the Scale"
- Save settings and exit the Setup menu:
Press /[TARE] for at least 2 sec.

Additional Functions

In addition to the functions for:

- power off (/[ON/OFF] key),
- zeroing (/[ZERO] key),
- taring (/[TARE] key), and
- printing (/[PRINT] key),

you can also access the following functions from this application:













- Start measuring ( key)
- Clear display of results ( key)
- Change number of measurements after clearing the display (/[TOGGLE] key)
- Display weight (/[TOGGLE] key)
- Calibration/adjustment (/[TARE] key; press for at least 2 sec.)

Example

Determine the weight of a sample in extremely unstable ambient conditions.
Enter the number of subweighs while in the weighing mode.

Settings (changes in the factory settings required for this example):

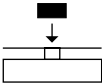
Menu: Application program: Averaging (2 : 12)

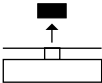
Step	Key (or instruction)	Display/Output
1. Turn on the scale	 /[ON/OFF]	
2. If necessary, zero the scale ( symbol: scale is zeroed – verified scales only)	 /[ZERO]	0.000 kg ¹⁰
3. Set the number of subweighs for averaging (here: 5 subweighs)	 /[TOGGLE]  /[TOGGLE]  /[TOGGLE]  /[TOGGLE]  /[TOGGLE]  /[TOGGLE]	rEF 20 (briefly) rEF 50 (briefly) rEF 100 (briefly) rEF 1 (briefly) rEF 2 (briefly) rEF 5 (briefly) 0.000 kg ⁵
4. Place sample on the scale (weight readout fluctuates; here: around 275 g)		+ 8888 ⁵
5. Start measurement; if the print format is set to include data ID codes, the following is printed		+ 8888 ^{5... 1} + 0.275 kg ⁵ Res + 0.275 kg
6. Unload the scale		+ 0.275 kg ⁵ (stable display)
7. Repeat the procedure starting from Step 4.		

Data Output Functions

There are 3 options for data output:

- Output to the display and control unit
- Output to a printer (generate a printout)
- Output to a peripheral device (e.g., computer) via the interface port

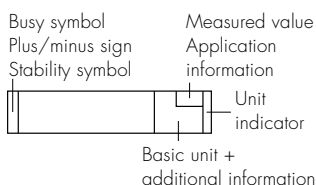

Output to the Display and Control Unit

The display is divided into 5 sections. Information about the scale, the application being used and the sample weighed is output in the following sections:

- Busy symbol, plus/minus sign, stability symbol
- Measured value line
- Basic units and additional identifiers
- Application parameter
- Weight unit indicator

Busy Symbol, Plus/Minus Sign, Stability Symbol

This section contains:

- ▲ – Busy symbol
- ± – Plus/minus sign
- – Zero indicator on verified scales
- ▼ – Calculated value indicator (flashing triangle; in the examples shown in this manual, it appears as a white triangle with a black border)

Measured Value Line

This section shows:

- Current weight (digits bordered with a broken line are invalid in use for legal metrology)
- Calculated values (e.g., piece counts)
- Application parameters during configuration (e.g., reference sample quantity, etc.)
- Software version (*r* = release; in this example: *19* = scale program; *01* = software version)

12509
35
-EF 100
r 1901

Weight Units, Additional Identifiers

This section shows:

- kg** – The current weight unit (e.g., kg)
- pcs** – Other unit of measurement (e.g., piece count)
- NET** – Indicates that there is data in the tare memory

Application Parameter (EB models only)

- 50** This section shows application parameters (e.g., reference sample quantity, no. of subweighs for averaging, etc.).

Weight Unit Indicator (EB models only)

- ▶ The arrows in this section indicate the configured weight units (upper arrow: weight unit 1; lower arrow: weight unit 2)

Printing a Data Record

Purpose

You can generate a printout of weights as well as other measured values and identifiers for documentation purposes. You can format the printout to meet individual requirements.

Available Features

The printout can be configured to include 2 user-defined header lines of 14 characters each. These text lines are entered either at the Sartorius factory or on location with a special program that uses the BPI interface command sequence.

Print an individual weight, or net, gross and tare weights.

Line format: You can configure a data ID code of up to 6 characters for each of the values printed; this data ID code is printed at the beginning of the line

Printouts generated automatically or by pressing the /[PRINT] key, dependent on or independent of scale stability

You can have the following values output automatically when using the application programs (EB models only) if menu code **7 12** or **7 13** is configured (printout with data ID codes):

- Second tare memory: last net value
- Counting: Reference weight for one piece (average piece weight)
- Weighing in percent: Reference weight for the percentage selected
- Totalizing: Current weight, total weight (net)
- Averaging: Result of measurement

Factory Settings

Header:

The default header lines do not contain any text

Print manual/automatic:

Individual printout or automatic printout dependent on scale stability:

Manual after stability (5 | 2)

Line format:

Up to 6 characters at the beginning of each line to identify the weight or calculated value:

Print net, tare, gross value with data ID (7 | 3)

- See the chapter entitled "Configuring the Scale" for instructions on setting parameters

Headers:

Examples

You can configure the printout to include 2 user-defined header lines.

The software required for configuring these lines via your PC is available from Sartorius in Goettingen or your local Sartorius office or dealer.

EISENMUELLER
GOETTINGEN

User-defined
User-defined

Printout without Data ID Codes:

The value currently displayed is printed (weight or calculated value with unit)

+	1530.0 g	Weight in grams
+	58.562 oz t	Weight in Troy ounces
+	253 pcs	Piece count
+	88.2 %	Percentage
+	105.8 o	Calculated value

Printout with Data ID Codes:

The current value displayed can be printed with a data ID code of up to 6 characters at the beginning of the line. You can use this data ID code, e.g., to designate a weight readout as a net weight (N) or a calculated value as a piece count (QNT).	N	+	1.530 kg	Current net weight
	N1	+	1.530 kg	Current net weight
	T	+	0.234 kg	Value in tare memory
	T1	+	0.102 kg	Value in 2nd tare memory
	G	+	1.553 kg	Current gross weight
	G#	+	1.630 kg	Calculated gross weight
	Qnt	+	253 pcs	Calculated quantity
	Prc	+	88.2 %	Calculated percentage
	Sum	+	1.279 kg	Total value (net)
	Res	+	1.530 kg	Calculated result

Print Application Parameters:

You can generate a printout of one or more of the values configured for initialization of an application as soon as you initialize the scale.	wRef	+	0.014 kg	Counting: Average piece weight
	Wxx%	+	1.200 kg	Weighing in percent: reference weight for the selected percentage

Auto Print:

You can have the weight readout printed automatically. The display update interval depends on the operating status of the scale and on the scale model.	N	+	1.530 kg	Net weight
	Stat			Display blank
	Stat		L	Display underload
	Stat		H	Display overload

Interface Description

Purpose

Your Economy/Express scale comes equipped with an interface port for connection to a computer or other peripheral device.

You can use an on-line computer to change, start and/or monitor the functions of the scale and the application programs (EB models only).

Available Features

Type of interface: Serial interface

Operating mode: Full duplex

Standard: RS-232

Transmission rates:

150; 300; 600; 1,200; 2,400; 4,800;
9,600 baud

Parity: Mark, space, odd, even

Character format:

1 start bit, 7-bit ASCII, parity, 1 or 2 stop bits

Handshake:

2-wire interface: via software (XON/XOFF)

4-wire interface: via hardware handshake lines
(CTS/DTR)

Operating mode: SBI

Data output format of the scale:

16 or 22 characters

Factory Settings:

Transmission rate: 1,200 baud (5 1 4)

Parity: Odd (5 2 3)

Stop bits: 1 stop bit (5 3 1)

Handshake:

Hardware, 1 character after CTS (5 4 3)

Operating mode: Standard SBI (5 5 1)

Print manually/automatically:

Manual after stability (5 1 2)

Preparation

- See the chapter entitled "Overview" for the pin assignment chart

Line Format (Data Output Format)

You can output the values displayed in the measured value line and the weight unit with or without a data ID code.

Example: Without data ID code

+ 253 pcs

Example: With data ID code

Qnt + 253 pcs

Configure this parameter in the Setup menu (Menu: Printout format 7 1 1 or 7 1 2 or 7 1 3).

The output without data ID code has 16 characters; with data ID code, 22 characters.

⚠ Note on Operation of the Scale with the YDP03-OCE Printer

- When data output with 22 characters per line is configured (menu code 7 . 1 . 2), the "GLP/GMP printout" setting in the printer must be set to "off" (-R 1- 0 = off)

Output Format With 16 Characters

Display segments that are not activated are output as spaces. Characters without a decimal point are output without a decimal point.

The following characters can be output, depending on the characters displayed on the scale:

Normal Operation

Position	1	2	3	4	5	6	7	8	9	10	11	12	13	14	15	16
	+				D	D	D	D	D	D	*	U	U	U	CR	LF
or	-		*	*	*		
or	*	*	*	*	*	*	*	*	*	*						
or					0	0	0	0	0	0						

*: Space
 D: Digit or letter
 U: Unit symbol
 CR: Carriage return
 LF: Line feed

Special Codes

Position	1	2	3	4	5	6	7	8	9	10	11	12	13	14	15	16
					*	*	-	-	*	*	*	*	*	*	CR	LF
or							H	*								
or							L	*								
or							C	*								

*: Space
 --: Weight
 H: Overload
 L: Underload
 C: Calibration/adjustment

Error Codes

Position	1	2	3	4	5	6	7	8	9	10	11	12	13	14	15	16
				*	*	E	*	#	#	#	*	*	*	*	CR	LF

*: Space

#: Error code number

Example: Data output example: + 1255.7 g

Position	1	2	3	4	5	6	7	8	9	10	11	12	13	14	15	16
	+	*	*	*	1	2	5	5	.	7	*	g	*	*	CR	LF

Position 1: Plus or minus sign or space

Position 2: Space

Position 3–10: Weight with a decimal point; leading zeros = space

Position 11: Space

Position 12–14: Unit symbol or space

Position 15: Carriage return

Position 16: Line feed

Output Format with 22 Characters

When data with an ID code is output, the ID code consisting of 6 characters precedes the data with the 16-character format. These 6 characters identify the following value.

1	2	3	4	5	6	7	8	9	10	11	12	13	14	15	16	17	18	19	20	21	22
						+	*	D	D	D	D	D	D	D	D	*	U	U	U	CR	LF
	*	*	*	*	*	-			*	*	*		
						*	*	*	*	*	*	*	*	*							
										0	0	0	0	0	0						

- I: ID code character¹⁾
- U: Unit symbol¹⁾
- *: Space
- CR: Carriage return
- D: Digit or letter
- LF: Line feed

¹⁾ depends on scale type; e.g., not all units and characters are available on scales verified for use in legal metrology (see also next page)

Special Codes

1	2	3	4	5	6	7	8	9	10	11	12	13	14	15	16	17	18	19	20	21	22
S	t	a	t	*	*	*	*	*	*	*	*	-	-	*	*	*	*	*	*	CR	LF
												H	*								
												L	*								

- *: Space
- H: Overload
- -: Weight
- L: Underload

Error Codes

1	2	3	4	5	6	7	8	9	10	11	12	13	14	15	16	17	18	19	20	21	22
S	t	a	t	*	*	*	*	*	E	r	r	*	#	#	#	*	*	*	*	CR	LF

- *: Space
- # # #: Error code number

ID code characters	Meaning
S t a t	Status
G	Gross
G #	Gross – calculated value
T	Tare T
T 1	Tare T1
N	Net N
N 1	Net N1
Q n t	Counting: quantity
P r c	Weighing in percent: percentage
R e s	Calculation, averaging: result
S u m	Totalizing: net total
w R e f	Automatic printout: average piece weight
W x x %	Automatic printout: reference percentage weight

Data Input Format

You can connect a computer to your scale to send commands via the scale interface port to control scale functions and applications (EB models only).

The commands sent are control commands and may have different formats; e.g., control commands can have up to 26 characters. Each character must be transmitted according to the settings configured in the Setup menu for data transmission.

Format for Control Commands

Format :	Esc	!	CR	LF
----------	-----	---	----	----

Esc:	Escape	CR:	Carriage return (optional)
!:	Command character	LF:	Line feed (optional)

Command character	!	Meaning
K		Weighing mode 1
L		Weighing mode 2
M		Weighing mode 3
N		Weighing mode 4
O		Block keys
P		Print
R		Release keys
S		Restart
T		Tare and zero (combined)
U		Tare ("Tare only")
V		Zero
W		External calibration/adjustment

Synchronization

During data communication between the scale and an on-line device (computer), messages consisting of ASCII characters are transmitted via the interface. For error-free data communication, the parameters for baud rate, parity, handshake mode and character format must be the same for both units.

You can set these parameters in the Setup menu so that they match those of the on-line device. You can also define parameters in the scale to make data output dependent on various conditions. The conditions that can be configured are described under each of the application program descriptions.

If you do not plug a peripheral device into the scale interface port, this will not generate an error message.

Handshake

The scale interface (Sartorius Scale Interface = SBI) has transmit and receive buffers. You can define the handshake parameter in the Setup menu:

- Hardware handshake (CTS/DTR)
- Software handshake (XON, XOFF)

Hardware Handshake

With a 4-wire interface, 1 more character can be transmitted after CTS (Clear to Send).

Software Handshake

The software handshake is controlled via XON and XOFF. When a device is switched on, XON must be transmitted to enable any connected device to communicate.

Activating Data Output

You can define the data output parameter so that output is activated either when a print command is received or automatically and synchronous with the scale display or at defined intervals (see application program descriptions (EB models only) and auto-print setting).

Data Output by Print Command

The print command can be transmitted by pressing /[PRINT] or by a software command (Esc P).

Automatic Data Output

In the "auto print" operating mode, data are output to the interface port without a print command. You can choose to have data output automatically at defined print intervals with or without the stability parameter. Whichever parameter you select, the data will be output as the readouts appear on the scale display. The display update frequency depends on the setting for "Adapting the Filter" (1.1.x.).

If you select the auto print setting, data will be transmitted immediately the moment you turn on the scale.

Pin Assignment Chart

Female Interface Connector:

25-position D-Submini, DB25S, with screw lock hardware for cable gland

Male Connector Used: (please use connectors with the same specifications):

25-pin D-Submini, DB25S, with integrated shielded cable clamp assembly (Amp type 826 985-1C) and fastening screws (Amp type 164 868-1)

Warning When Using Pre-wired RS-232 Connecting Cables!

RS-232 cables purchased from other manufacturers often have incorrect pin assignments for use with Sartorius scales. Be sure to check the pin assignment against the chart below before connecting the cable, and disconnect any lines marked "Internally Connected" (e.g., pin 6). Failure to do so may damage or even completely ruin your scale and/or peripheral device.

Pin Assignment Chart:

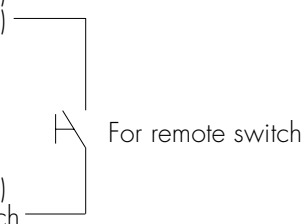
Pin 1:	Signal ground	
Pin 2:	Data Output (TxD)	
Pin 3:	Data Input (RxD)	
Pin 4:	Internal Ground (GND)	
Pin 5:	Clear to Send (CTS)	
Pin 6:	Internally Connected	
Pin 7:	Internal Ground (GND)	
Pin 8:	Internal Ground (GND)	
Pin 9:	Internally Connected	
Pin 10:	Not Connected	
Pin 11:	Not Connected	
Pin 12:	Reset _ Out *)	
Pin 13:	Internally Connected	
Pin 14:	Internal Ground (GND)	
Pin 15:	Universal Remote Switch	
Pin 16:	Not Connected	
Pin 17:	Not Connected	
Pin 18:	Not Connected	
Pin 19:	Not Connected	
Pin 20:	Data Terminal Ready (DTR)	
Pin 21:	Ground input for external power supply (GND _ V in)	
Pin 22:	Internally Connected	
Pin 23:	Internally Connected	
Pin 24:	Power supply input +12 ... 30 V	
Pin 25:	Not Connected	

*) = Hardware restart

Cabling Diagram

- Diagram for interfacing a computer or different peripheral device to the scale using the RS-232/V24 standard and cables up to 1.5 m (50 ft.) long

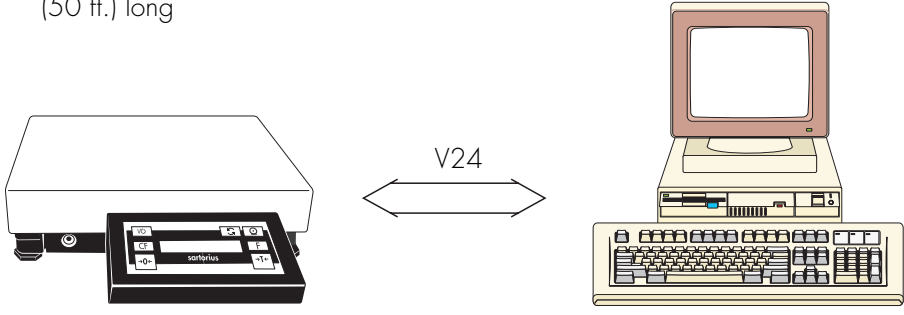

Scale

Peripheral Device (PC)

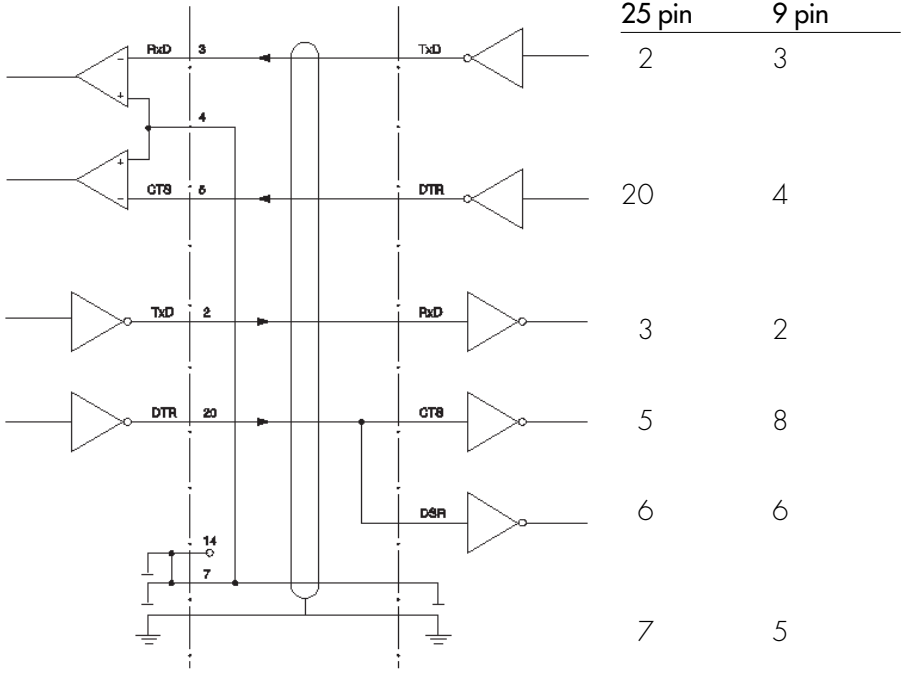

Type of cable: AWG 24 specification

Configuring the Scale

Setting the Parameters (Menu)

Purpose

You can configure your Economy/Express scale to meet individual requirements by selecting from the parameters available in the menu.

Parameters that are not permitted in legal metrology are not shown in the menu on verified scales.

Features









The parameters are divided into the following groups (1st menu level):

- 1 Scale functions
- 2 Application programs
- 3 Application parameters
- 5 Data interface
- 6 Print for weighing
- 7 Print for application
- 8 Extra functions
- 9 Reset menu to factory-set parameters

Factory-Set Parameters

















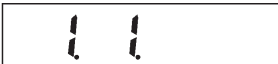

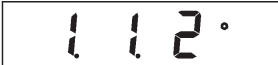
The factory-set parameters are marked by an "o" in the list starting on page 64.

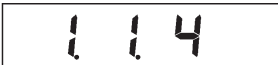
Preparation

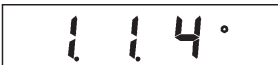
- Turn off the scale: Press /[ON/OFF]
- Turn on the scale: Press /[ON/OFF]; while all segments are displayed, press /[TARE] briefly
- > Measured value line: **!** (1st menu level)
- To navigate within a menu level: Press /[TARE]; when you reach the last menu item, the first is shown again
- To select the next sublevel within a group: Press /[PRINT] briefly.
- To return to the higher menu level: Press /[PRINT]
- To confirm selected parameters: Press and hold /[PRINT] for more than two seconds
- > "o" indicates the selected menu code
- To store parameter settings and exit the menu: Press and hold the /[TARE] key
- To exit the menu without storing any new settings: Press /[ON/OFF]
- > Restart the application

Example

Adapt the scale to unstable ambient conditions: Menu code 1.1.4

Step	Key	Display
1. Turn the scale off	 /[ON/OFF]	
2. Turn the scale back on;	 /[ON/OFF]	
while all segments are displayed	 /[TARE] briefly	
3. Confirm 1st menu level (scale functions)	 /[PRINT]	
4. Confirm "Adapt filter" group (2nd menu level)	 /[PRINT]	
5. Menu level 3: Select the desired menu item	 /[TARE] repeatedly	
6. Confirm selected item	 /[PRINT] for 2 seconds	
7. Set other parameters, if desired	 /[PRINT],  /[TARE]	
8. Saves changes and exit menu	 /[TARE] for 2 seconds	

Scale Operating Menu (Overview)

- Factory setting
- √ User setting

Menu items that are only available in the EB and not in the EA model are marked by shading.

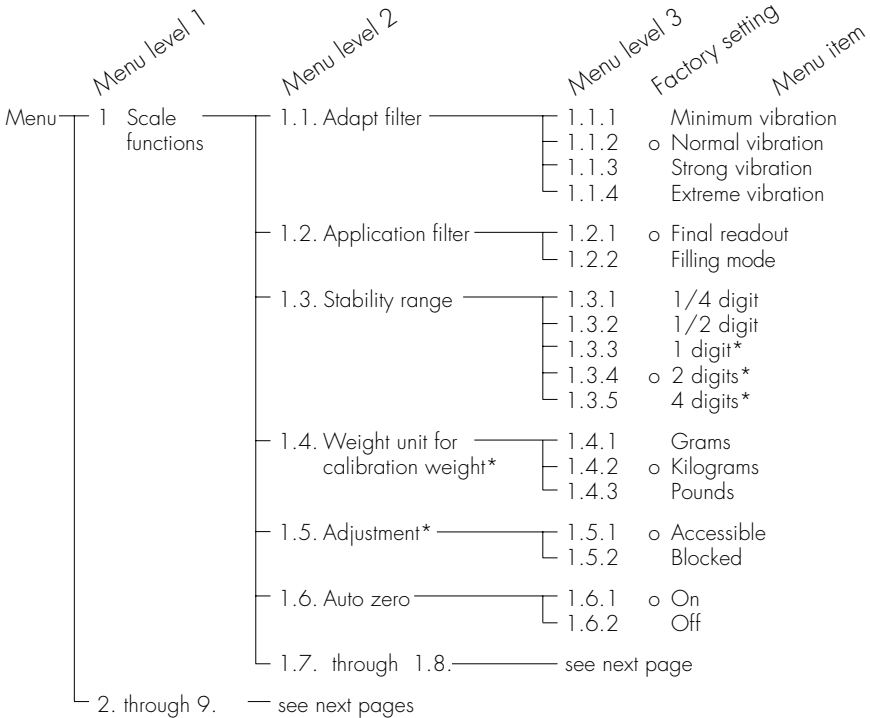

* = These settings cannot be changed on verified scales

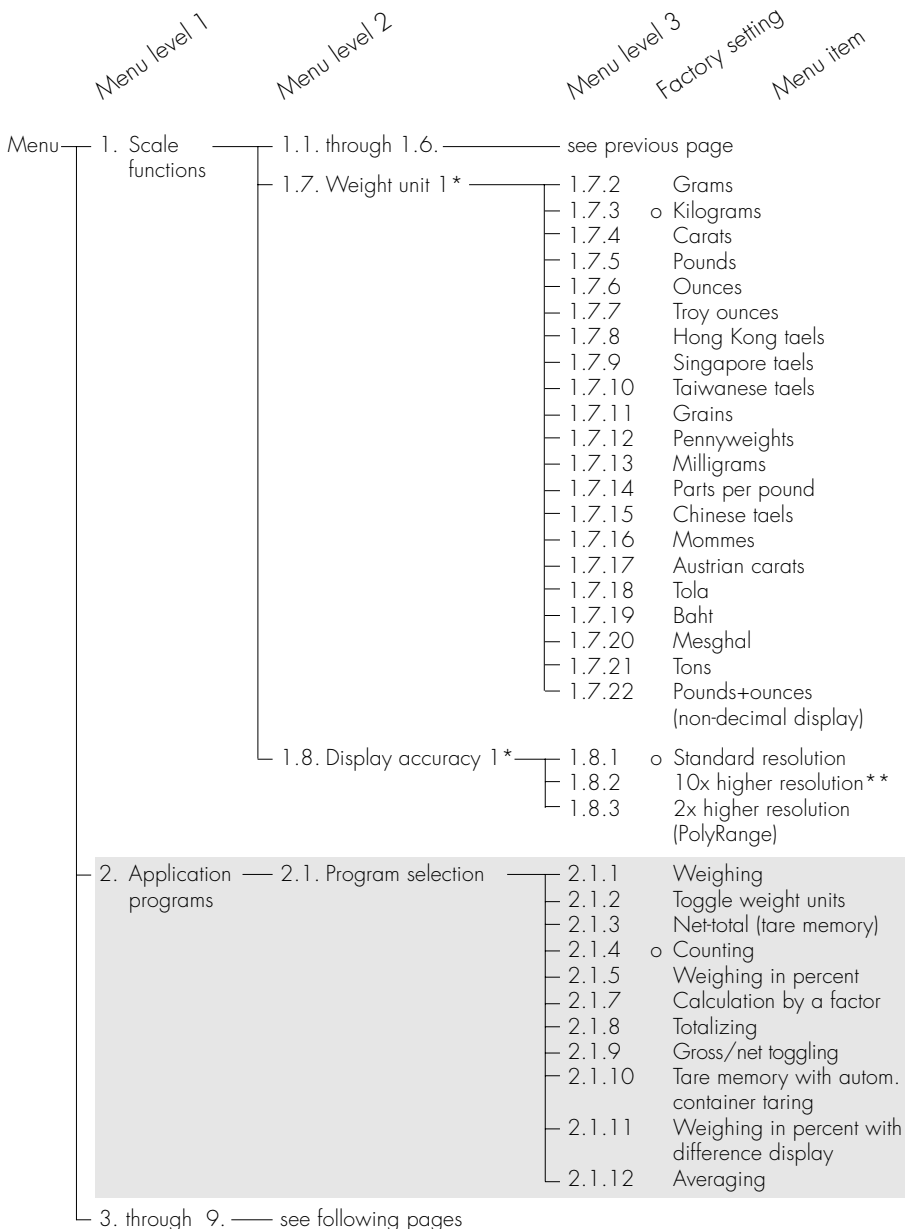

* = These settings cannot be changed on verified scales
 ** = Only for EB...-OUR models

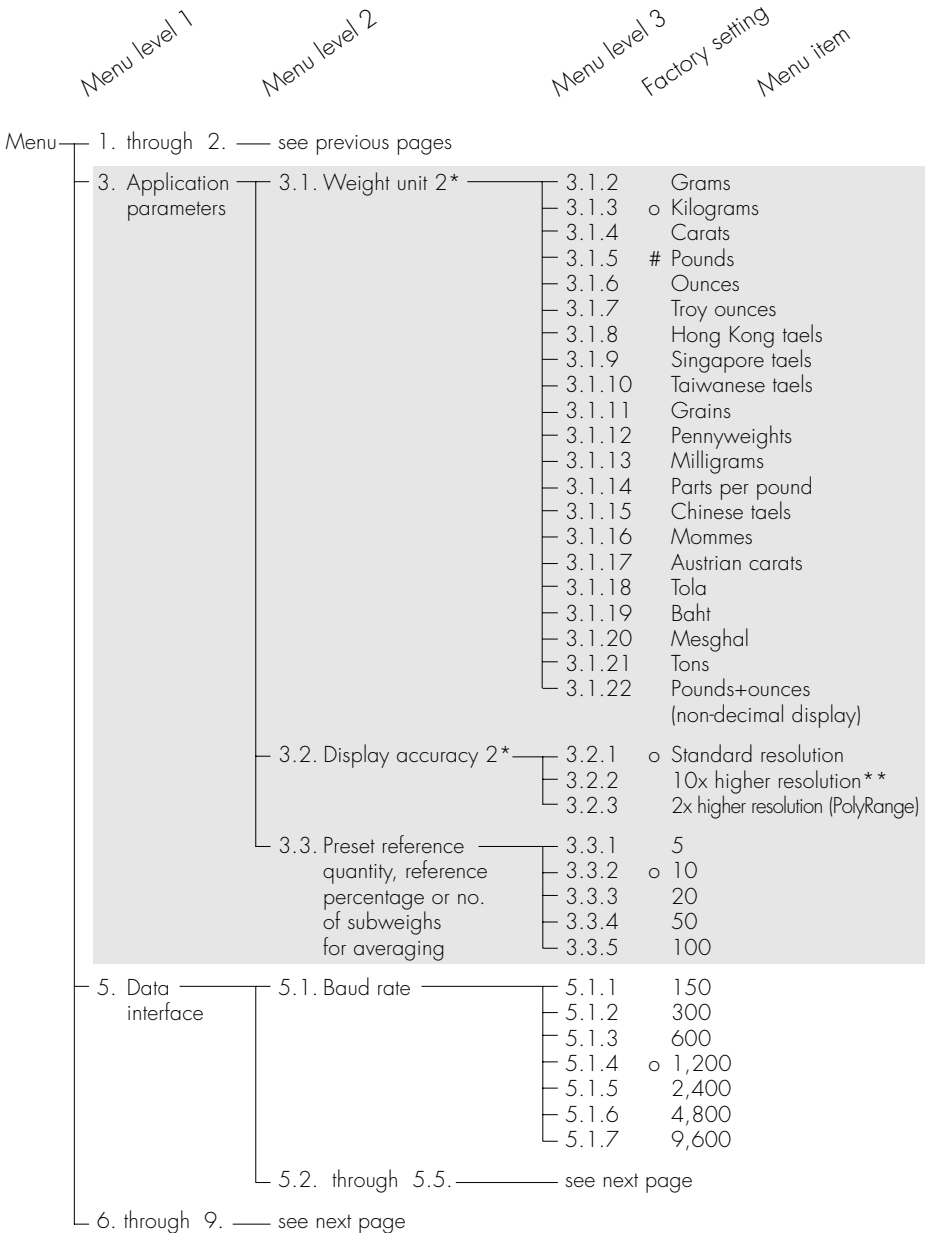

= Factory setting on scale model EA/EB ...UR
 * = These settings cannot be changed on verified scales
 ** = Only for EB...-OUR models

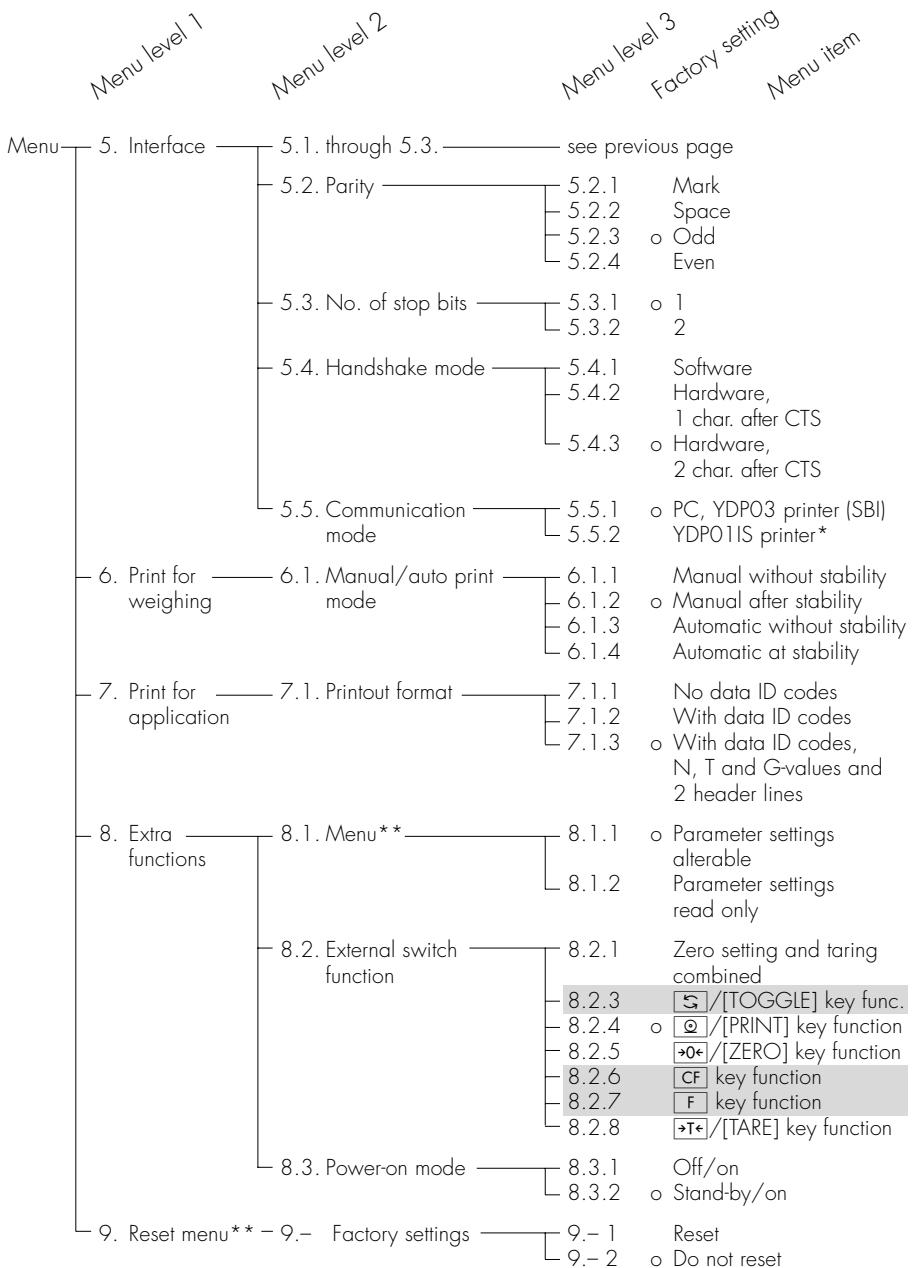

* = To operate the YDPO11S, also set menu item 5.1.7 "9,600 baud"

** = Not for EB...OUR

Error Codes

Error codes are shown in the main display for approx. 2 seconds, after which the program automatically returns to the weighing mode.

Display	Cause	Solution
No segments appear on the display	No AC power is available	Check the AC power supply
	The AC adapter is not plugged in	Plug in the AC adapter
	Automatic shutoff is configured	Turn on the scale
	Rechargeable battery has run down	Recharge battery (see battery instructions)
H	The load exceeds the scale capacity	Unload the scale
L	The load plate is not in place	Place the load plate on the scale
	Something is touching the load plate	Move the object that is touching the load plate
E 01	Data output not compatible with input format	Change the configuration in the Setup menu
E 02	Calibration parameter not met; e.g.:	Calibrate only when zero is displayed
	– scale not zeroed – scale is loaded	Press $\rightarrow 0 \leftarrow$ / [ZERO] to zero the scale Unload the scale
E 08	The scale was zeroed outside the zero range	Only zero the scale when in the zero range; i.e.: (2% of the maximum capacity
E 09	Taring is not possible when the gross weight is \leq zero	Press $\rightarrow 0 \leftarrow$ / [ZERO] to zero the scale

Display	Cause	Solution
E 10	The $\rightarrow T \leftarrow$ /[TARE] key is blocked when there is data in the second tare memory (net-total) – only 1 tare function can be used at a time	Press $\square CF$ to clear the tare memory and release the tare key
E 11	Tare memory not accessible	Press $\rightarrow 0 \leftarrow$ /[ZERO]
E 22	Weight is too light or there is no sample on the scale	Increase the reference quantity
E 30	Interface port for printer output is blocked	Perform "Reset menu" or Contact your local Sartorius Service Center
The maximum weighing capacity is less than is indicated in "Specifications"	The scale was turned on without the load plate in place	Press the $\square ON/OFF$ key to turn the scale off and back on again
The weight readout changes constantly	Unstable ambient conditions	Set up the scale in another area
	Too much vibration, or the scale is exposed to a draft	Change setup configuration to adapt the scale to the ambient conditions
	A foreign object is caught between the load plate and the scale frame	Remove the foreign object
The weight readout is obviously wrong	The scale has not been calibrated/adjusted	Calibrate/adjust the scale
	The scale was not tared before weighing	Tare before weighing

If any other errors occur, contact your local Sartorius Service Center!

Care and Maintenance

Service

Regular servicing by a Sartorius technician will extend the service life of your scale and ensure its continued weighing accuracy. Sartorius can offer you service contracts, with your choice of regular maintenance intervals ranging from 1 month to 2 years.

The frequency of these maintenance intervals depends on the operating conditions and your requirements concerning the tolerances for the scale.

Repairs

Repair work must be performed by trained service technicians. Any attempt by untrained persons to perform repairs may lead to hazards for the user.

Cleaning

- ⚠️ Disconnect the scale from the AC adapter and unplug any data cables that are connected to the scale
- ⚠️ Make sure that no liquids enter the scale housing
- ⚠️ Do not use any aggressive cleaning agents (solvents or similar agents)
- Unplug the AC adapter from the wall outlet (mains supply)
- If you have a data cable connected to the interface, unplug it from the scale
- Clean the scale using a piece of cloth which has been wet with a mild detergent (soap)

- After cleaning, wipe down the scale with a soft, dry cloth

Safety Inspection

If there is any indication that safe operation of the scale with the AC adapter is no longer warranted:

- Turn off the power and disconnect the equipment from AC power immediately
- > Lock the equipment in a secure place to ensure that it cannot be used for the time being

Safe operation of the scale with the AC adapter is no longer ensured when:

- there is visible damage to the AC adapter
- the AC adapter no longer functions properly
- the AC adapter has been stored for a relatively long period under unfavorable conditions

In this case, notify your nearest Sartorius Service Center or the International Technical Support Unit based in Goettingen, Germany. Maintenance and repair work may only be performed by service technicians who are authorized by Sartorius and who

- have access to the required maintenance manuals
- have attended the relevant service training courses

Instructions for Recycling the Packaging

To ensure safe shipment, your scale has been packaged using environmentally friendly materials. After successful installation of the scale, you should return this packaging for recycling.

For information on recycling options, including recycling of old weighing equipment, contact your municipal waste disposal center or local recycling depot.

Overview

General View of the Scale

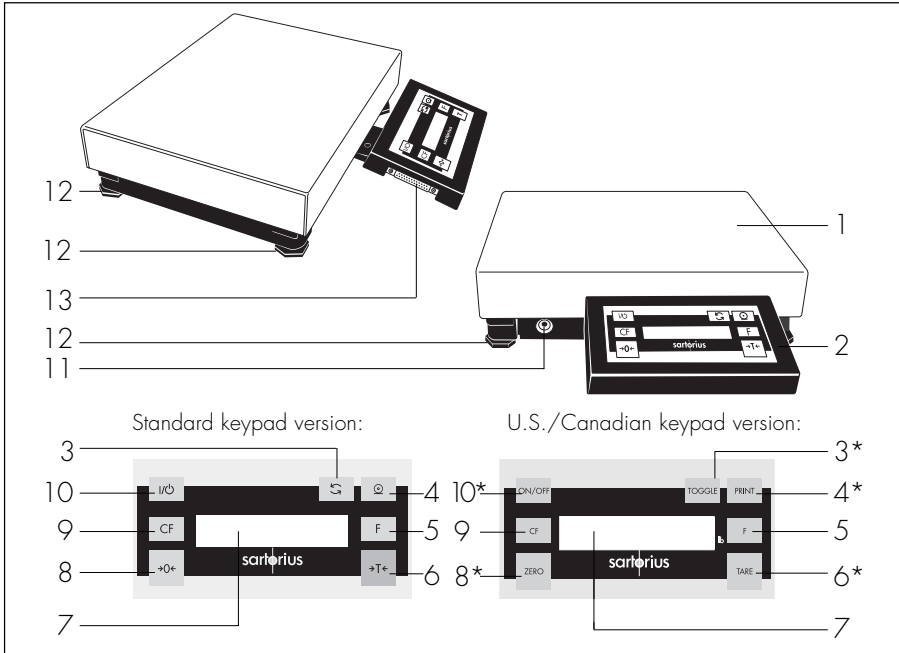

No.	Designation	Order no. for replacement	No.	Designation	Order no. for replacement
-----	-------------	---------------------------	-----	-------------	---------------------------

1	Load plate – EA/EB ... DCE: 69EA0011 – EA/EB ... EDE: 69EA0004 – EA/EB ... FEG: 69EA0017		7	Display	
2	Display and control unit		8	Zero key	
3	Toggle key (EB models only)		9	Clear function key (EB models only)	
4	Print key		10	On/off key	
5	Function key (EB models only)		11	DC jack	
6	Tare key		12	Leveling feet Set: 69EA0020	
			13	Data interface port	
			Not shown: Protective cap for interface port		69LC0084

* = As shown in this illustration, there are some differences between the standard and the U.S./Canadian keypad versions.

Description of the Keys

/[ON/OFF] key:
On/off switch

Switches the display on/off. The scale remains in the standby mode.

/[ZERO] key: Zero

Sets the readout to zero. The scale can only be zeroed if the load is $\pm 2\%$ of the maximum capacity.

 key: Clear Function

This key is generally used to interrupt/cancel functions:

- Clear memory and delete application data
- Interrupt calibration/adjustment routines

/[TOGGLE] key:
Toggle

For toggling the display between weighed and calculated values (counting result, percentage, calculated result)

For changing the reference quantity/percentage or numbers of subweighs for averaging

 key:
Start Application Program

The procedure that follows after this key is pressed depends on the application program selected; for a complete description, see the chapter entitled "Operating the Scale" in the corresponding section.

/[TARE] key: Tare

For taring the weight of containers so that the scale readout shows the net weight of samples.

/[PRINT] key:
Data Output

Press this key to output the displayed values to via the built-in interface to a Sartorius "Data Printer" or a computer.

Specifications

Standard models

Model		EA/EB 3DCE-L	EA/EB 6DCE-L	EA/EB 15DCE-L	EA/EB 35EDE-L	EA/EB 60EDE-L	EA/EB 60FEG-L	EA/EB 150FEG-L
Weighing capacity	kg	3	6	15	35	60	60	150
	lb	6.6	13.2	33	77	132	132	330
Readability	g	1	2	5	10	20	20	50
Maximum load	kg	6	12	30	70	120	120	300
Tare range (by subtraction)	kg	3	6	15	35	60	60	150
Reproducibility	≤±g	1	2	5	10	20	20	50
Linearity	≤±g	1	2	5	10	20	20	50
Sensitivity drift within -10...+40°C	ppm/ K	100	100	100	100	100	100	125
External calibration weight (of at least accuracy class...)	kg	2 (M1)	2 (M1)	5 (M1)	10 (M1)	20 (M1)	20 (M1)	50 (M1)
	lb	5 (M1)	5 (M1)	10 (M1)	20 (M1)	50 (M1)	50 (M1)	100 (M1)
Net weight, approx.	kg	5	5	5	8	8	24	24
Dust and water protection rating for the weighing platform according to EN 60529		IP54						
Dust protection rating for the display and control unit according to EN 60529		IP40						
AC power source/ power requirements		AC adapter, 230 or 115 V, +15% ... -20%						
Frequency		48 – 60 Hz						
Power consumption		maximum 16 VA; average 8 VA						
Operating temperature range		-10 ... +40°C (263 ... 313 K, 14°F ... 104°F)						
Adaptation to ambient conditions		By selection of 1 of 4 optimized filter levels						
Display update (depends on the filter level selected)		0.1 – 0.4						
Hours of operation with fully charged YRB 05 Z external battery pack, approx.		48 h						
Selectable weight units		Grams, kilograms, carats, pounds, ounces, Troy ounces, Hong Kong taels, Singapore taels, Taiwanese taels, grains, pennyweights, milligrams, parts per pound, Chinese taels, mommes, Austrian carats, tola, baht, mesghal and tons						
Built-in interface		RS-232						
Format:		7-bit ASCII, 1 start bit, 1 or 2 stop bits						
Parity:		mark, odd, even or space						
Transmission rates:		150 to 9,600 baud						
Handshake mode:		Software or hardware						

Model		EA/EB	EA/EB	EA/EB	EA/EB	EA/EB	EA/EB
		6DCE-L	12DCE-L	30EDE-L	60EDE-L	60FEG-L	120FEG-L
		OUR	OUR	OUR	OUR	OUR	OUR
Weighing capacity	kg	6	12	30	60	60	120
	lb	13.2	26.4	66	132	132	264.5
Readability	g	1	2	5	10	10	20
Maximum load	kg	12	30	70	120	120	300
Tare range (by subtraction)	kg	6	12	30	60	60	120
Reproducibility	≤±g	1	2	5	10	10	20
Linearity	≤±g	1	2	5	10	10	20
Sensitivity drift within +5...+35°C	ppm/						
	K	50	50	50	50	50	50
External calibration weight (of at least accuracy class...)	kg	2 (M1)	5 (M1)	10 (M1)	20 (M1)	20 (M1)	50 (M1)
	lb	5 (M1)	10 (M1)	20 (M1)	50 (M1)	50 (M1)	100 (M1)
Net weight, approx.	kg	5	5	8	8	24	24
Dust and water protection rating for the weighing platform according to EN 60529		IP54					
Dust protection rating for the display and control unit according to EN 60529		IP40					
AC power source/ power requirements		AC adapter, 230 or 115 V, +15% ... -20%					
Frequency		48 – 60 Hz					
Power consumption		maximum 16 VA; average 8 VA					
Operating temperature range		-10 ... +40°C (263 ... 313 K, 14°F ... 104°F)					
Adaptation to ambient conditions		By selection of 1 of 4 optimized filter levels					
Display update (depends on the filter level selected)		0.1 – 0.4					
Hours of operation with fully charged YRB 05 Z external battery pack, approx.		48 h					
Selectable weight units		Grams, kilograms, carats, pounds, ounces, Troy ounces, Hong Kong taels, Singapore taels, Taiwanese taels, grains, pennyweights, milligrams, parts per pound, Chinese taels, mottes, Austrian carats, tola, baht, mesghal and tons					
Built-in interface		RS-232					
Format:		7-bit ASCII, 1 start bit, 1 or 2 stop bits					
Parity:		mark, odd, even or space					
Transmission rates:		150 to 9,600 baud					
Handshake mode:		Software or hardware					

Model		EA/EB 3DCE-I	EA/EB 6DCE-I (OUR)	EA/EB 15DCE-I (OUR)	EA/EB 35EDE-I (OUR)	EA/EB 60EDE-I (OUR)	EA/EB 60FEG-I (OUR)	EA/EB 150FEG-I (OUR)
Weighing capacity	kg lb	3 6.6	6 13.2	15 33	35 77	60 132	60 132	150 330
Readability	g	0.1	0.2	0.5	1	2	2	5
Maximum load	kg	6	12	30	70	120	120	300
Tare range (by subtraction)	kg	3	6	15	35	60	60	150
Reproducibility	≤±g	0.2	0.2	0.5	1	2	2	5
Linearity	≤±g	0.2	0.4	1	2	4	4	10
Sensitivity drift within +5...+35°C	ppm/ K	10	10	10	10	10	10	10
External calibration weight (of at least accuracy class...)	kg lb	2 (F2) 5 (F2)	2 (F2) 5 (F2)	5 (F2) 10 (F2)	10 (F2) 20 (F2)	20 (F1) 50 (F1)	20 (F2) 50 (F2)	50 (F2) 100 (F2)
Net weight, approx.	kg	5	5	5	8	8	24	24
Dust and water protection rating for the weighing platform according to EN 60529		IP54						
Dust protection rating for the display and control unit according to EN 60529		IP40						
AC power source/power requirements		AC adapter, 230 or 115 V, +15% ... - 20%						
Frequency		48 – 60 Hz						
Power consumption		maximum 16 VA; average 8 VA						
Operating temperature range		-10 ... +40°C (263 ... 313 K, 14°F ... 104°F)						
Adaptation to ambient conditions		By selection of 1 of 4 optimized filter levels						
Display update (depends on the filter level selected)		0.1 – 0.4						
Hours of operation with fully charged YRB 05 Z external battery pack, approx.		48 h						
Selectable weight units		Grams, kilograms, carats, pounds, ounces, Troy ounces, Hong Kong taels, Singapore taels, Taiwanese taels, grains, pennyweights, milligrams, parts per pound, Chinese taels, mommies, Austrian carats, tola, baht, mesghal and tons						
Built-in interface		RS-232						
Format:		7-bit ASCII, 1 start bit, 1 or 2 stop bits						
Parity:		mark, odd, even or space						
Transmission rates:		150 to 9,600 baud						
Handshake mode:		Software or hardware						

Models Verified by the Manufacturer with EC Type Approval

Model	EA/EB 3DCE-L	EA/EB 6DCE-L	EA/EB 15DCE-L	EA/EB 30EDE-L	EA/EB 35EDE-L	EA/EB 60EDE-L
	OCE	OCE	OCE	OCE	OCE	OCE
Type designation	DS BH 300			DN BH 300		DN BH 300
Accuracy class*	III	III	III	III	III	III
Weighing capacity, max.*	kg 3	6	15	30	35	60
Scale interval d* (Readability)	g 1	2	5	10	10	20
Verification scale interval e*	g 1	2	5	10	10	20
No. of scale intervals*	e 3,000	3,000	3,000	3,000	3,500	3,000
Minimum capacity, min.*	g 20	40	100	200	200	400
Application range acc. to CD*	kg 0.02-3	0.04-6	0.1-15	0.2-30	0.2-35	0.4-60
Maximum load	kg 6	12	30	70	70	120
Tare range (by subtraction))	≤ 100% of maximum weighing capacity					
Net weight, approx.	kg 5	5	5	8	8	8
Dust and water protection rating for the weighing platform	IP54					
Dust protection rating for the display and control unit	IP40					
AC power source/power	AC adapter, 230 or 115 V, +15% ... -20% requirements					
Frequency	48 – 60 Hz					
Power consumption	maximum 16 VA; average 8 VA					
Operating temperature range	-10 ... +40 °C					
Adaptation to ambient conditions	By selection of 1 of 4 optimized filter levels					
Display update (depends on the filter level selected)	0.1 – 0.4					
Hours of operation with fully charged YRBO5Z external battery pack, approx.	48 h					
Weight unit	Kilograms					
Built-in interface	RS232C					
Format:	7-bit ASCII, 1 start bit, 1 or 2 stop bits					
Parity:	mark, odd, even or space					
Transmission rates:	150 to 9,600 baud					
Handshake mode:	Software or hardware					

* CD = Council Directive 90/384/EEC on non-automatic weighing instruments used in the EU and the Signatories of the Agreement on the European Economic Area

Model	EA/EB 60FEG-L OCE	EA/EB 150FEG-L OCE
Type designation	DQ BH 300	DQ BH 300
Accuracy class*	Ⓜ	Ⓜ
Weighing capacity, max.*	kg 60	150
Scale interval d* (Readability)	g 20	50
Verification scale interval e*	g 20	50
No. of scale intervals*	e 3,000	3,000
Minimum capacity, min.*	g 400	1,000
Application range acc. to CD*	kg 0.4–60	1–150
Maximum load	kg 120	300
Tare range (by subtraction)	≤ 100% of maximum weighing capacity	
Net weight, approx.	kg 24	24
Dust and water protection rating for the weighing platform	IP54	
Dust protection rating for the display and control unit	IP40	
AC power source/power	AC adapter, 230 or 115 V, +15% ... – 20% requirements	
Frequency	48 – 60 Hz	
Power consumption	maximum 16 VA; average 8 VA	
Operating temperature range)	–10 ... +40°C	
Adaptation to ambient conditions	By selection of 1 of 4 optimized filter levels	
Display update (depends on the filter level selected)	0.1 – 0.4	
Hours of operation with fully charged YRBO5Z external battery pack, approx.	48 h	
Weight unit	Kilograms	
Built-in interface	RS232C	
Format:	7-bit ASCII, 1 start bit, 1 or 2 stop bits	
Parity:	mark, odd, even or space	
Transmission rates:	150 to 9,600 baud	
Handshake mode:	Software or hardware	

* CD = Council Directive 90/384/EEC on non-automatic weighing instruments used in the EU and the Signatories of the Agreement on the European Economic Area

Dimensions

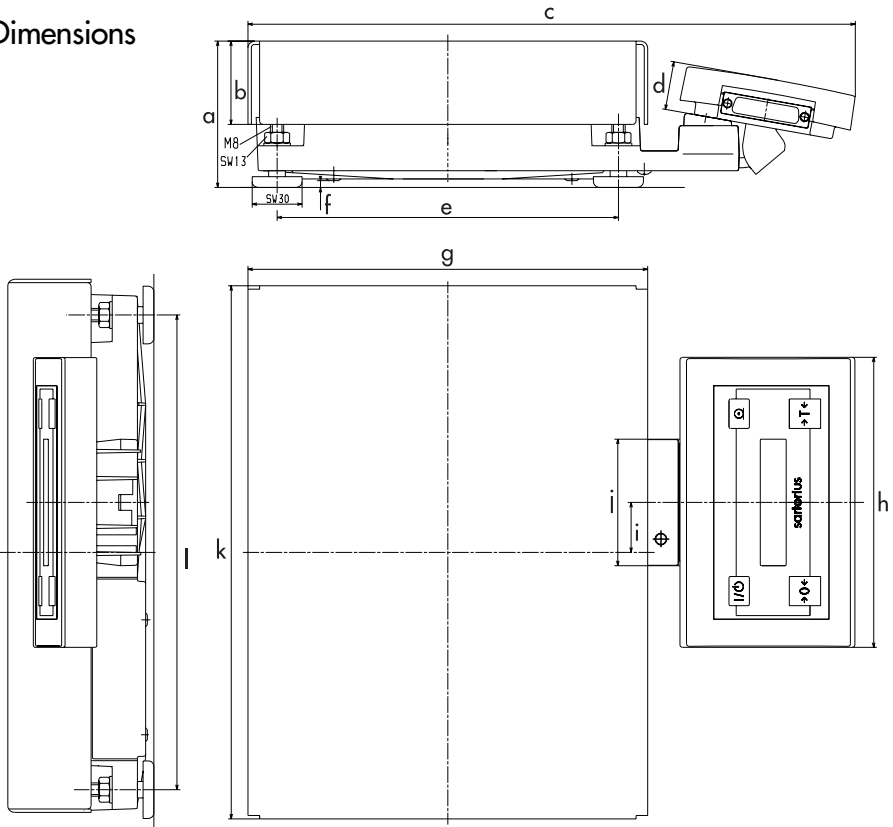

Dimensions (in millimeters/inches)

Model	a	b	c	d	e	f	g	h	i	j	k	l	
EA/EB	mm	min.87	50	365	29	205	min.4	240	174	30	76	320	285
3/6DCE-L (-H)	in	3.4	1.97	14.38	1.14	8.07	0.16	9.45	6.85	1.18	2.99	12.60	11.22
EA/EB12/15	mm	min.87	50	365	29	205	min.4	240	174	30	76	320	285
DCE-L (-H)	in	3.4	1.97	14.38	1.14	8.07	0.16	9.45	6.85	1.18	2.99	12.60	11.22
EA/EB30/	mm	min.90	53	425	29	265	min.4	300	174	60	76	400	365
35EDE-L (-H)	in	3.54	2.09	16.73	1.14	10.43	0.16	11.81	6.85	2.36	2.99	15.75	14.37
EA/EB	mm	min.90	53	425	29	265	min.4	300	174	60	76	400	365
60EDE-L (-H)	in	3.54	2.09	16.73	1.14	10.43	0.16	11.81	6.85	2.36	2.99	15.75	14.37
EA/EB	mm	min.96	60	527	29	343		400	174		79	500	443
60FEG-L (-H)	in	3.78	2.36	20.75	1.14	13.50		15.75	6.85		3.11	19.69	17.44
EA/EB120/	mm	min.96	60	527	29	343		400	174		79	500	443
150FEG-L(-H)	in	3.78	2.36	20.75	1.14	13.50		15.75	6.85		3.11	19.69	17.44

Accessories (Options)

Product

Order No.

Data Printer

YDP03-OCE

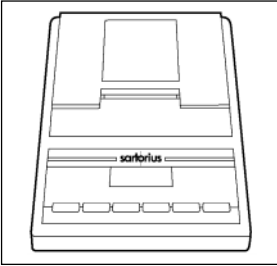

with date/time, statistical data evaluation and transaction counter functions and LCD (can only be operated with an AC adapter)

can be used in legal metrology

AC adapter for the Data Printer for use in

Europe

6971412

Great Britain

6971414

USA

6971413

Australia

6971411

South Africa

6971410

Paper (5 rolls)

6906937

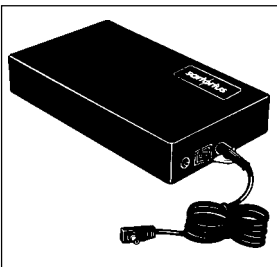

External rechargeable battery pack YRB05Z







has a battery-level indicator (LED);
can be recharged using the AC adapter (time it takes to charge the discharged battery pack: 1.5 hours); see "Specifications" for hours of operation

can be used in legal metrology

Calibration weights

Information on request

for all EA and EB scales;
extensive assortment, optionally available with officially recognized DKD certificates (DKD is the German Calibration Service)

SartoWedge data transfer software	YSW01
enables you to have the data recorded by your scale input directly into any application program you are running on your PC (e.g., Excel). Memory-resident software (5 KB) for all IBM-compatible computers and scales that are equipped with a serial interface and run under DOS and Windows.	
Data cable	7357312
for connecting a PC; 25-pin	
Adapter cable	6965619
for connecting a 25-pin D-Submini plug to a 9-position D-Submini socket; 0.25 m (approx. 10 in.)	
Cable for connecting the weighing platform to a separate display and control unit; length: 20 m (approx. 65.6 ft.)	Information on request
Universal remote control switch	
for remote control of one of the following functions (configured in the scale Setup menu):	
 /[PRINT],  /[ZERO],  /[TARE],  [F],  [CF],  /[TOGGLE]	
Foot switch with T-connector	YFS01
(can only be connected via the YTC01 T-connector)	
Hand switch with T-connector	YHS01
(can only be connected via the YTC01 T-connector)	
T-Connector	YTC01
Support arm	
(for raised display configuration)	
for EA/EB ... DCE models	YDH01EA
for EA/EB ... DCE/EDE models	YDH02EA
for EA/EB ... FEG models	YDH04EA
Table/wall mounting	
for the display and control unit	YDH03EA
Dust cover	
for display and control unit	YDC01EA

Information on EC Verification

Performance of initial verification by Sartorius AG is documented on the scale by the following label:



1. Explanation:

CE: EC mark of conformity

Green "M": Initial verification has already been performed on this instrument

98: Year in which the initial verification was performed, in this case 1998

0111: In Germany, Sartorius AG has been accredited by the Metrology Authority of Lower Saxony to perform EC verification, Notified Body of the European Community No. 0111.

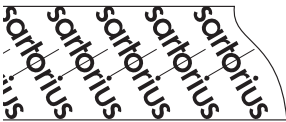

2. This security strip is affixed after the initial verification of weighing instruments of accuracy class $\text{\textcircled{III}}$ and seals it against unauthorized tampering with the metrological data. If the security strip is damaged, the verification is not valid and the weighing instrument is no longer approved for legal metrology.

Therefore, please check the status of the security ID label on your scale.

Using Verified Scales Approved for Use as Legal Measuring Instruments in the EU*

This scale is not allowed to be used for weighing goods intended for direct sale to the public. The type-approval certificate for verification applies only to non-automatic weighing instruments; for automatic operation with or without auxiliary measuring devices, you must comply with the regulations of your country applicable to the place of installation of your scale.

- The temperature range indicated on the verification ID label (°C) must not be exceeded during operation
- The scale must not be removed from the geographical zone indicated on the verification ID label. If moved outside this zone, the scale must be re-calibrated, re-adjusted and re-verified.
 - “50–52: 0–500” on the label indicates:
 - 50–52: 50 to 52 degrees latitude
 - 0–500: Height above mean sea level M.S.L. (e.g., Goettingen is within this zone and altitude)

Alternative:

The specific country can be indicated instead of the geographical zone.

Any time the scale is re-calibrated and/or re-adjusted following repairs, after the verification seal has been broken, after changing the setting of the menu access switch, etc., you must observe the applicable national laws and regulations governing the use of weighing instruments in legal metrology in your country. Make sure to change the information on the label indicating the zone of use to the location of use if you set up the scale in a new location.

* including the Signatories of the Agreement on the European Economic Area

“New Installation” Service

Initial verification is covered in our “New Installation” service package. In addition to initial verification, this package provides you with a series of important services which will guarantee you optimal results in working with your weighing instrument:

- Installation
- Startup
- Inspection
- Training
- Initial verification

If you would like Sartorius to perform initial verification of your weighing instrument, contact an authorized service representative.

“EC Verification” – A Service offered by Sartorius

Our service technicians are authorized to perform the verification* of your weighing instruments that are acceptable for legal metrological verification and can inspect and verify the metrological specifications at the place of installation within the Member States of the European Union and the Signatories of the Agreement on the European Economic Area.

Subsequent Verifications within the European Countries

The validity of the verification will become void in accordance with the national regulations of the country in which the weighing instrument is used. For information on verification and legal regulations currently applicable in your country, and to obtain the names of the persons to contact, please contact your local Sartorius office, dealer or service center.

* in accordance with the accreditation certificate issued to Sartorius AG

Declarations of Conformity

The CE Mark on Sartorius Equipment

In 1985, the Council of the European Community approved a resolution concerning a new approach to the technical harmonization and standardization of national regulations. The organization for monitoring compliance with the directives and standards concerning CE marking is governed in the individual EU Member States through the implementation of the EC Directives adopted by the respective national laws. As of December 1993, the scope of validity for all EC Directives has been extended to the Member States of the European Union and the Signatories of the Agreement on the European Economic Area.

Sartorius complies with the EC Directives and European Standards in order to supply its customers with weighing instruments and related equipment that feature the latest advanced technology and provide many years of trouble-free service.

The CE mark may be affixed only to weighing instruments and associated equipment that comply with the applicable Directive(s):

Council Directive 89/336/EEC "Electromagnetic Compatibility (EMC)"

Acceptable European Standards:

Limitation of emissions:

EN 50081-1 Residential, commercial and light industry

EN 50081-2 Industrial environment

Defined immunity to interference:

EN 50082-1 Residential, commercial and light industry

EN 50082-2 Industrial environment

Important Note:

The operator shall be responsible for any modifications to Sartorius equipment and for any connections of cables or equipment not supplied by Sartorius and must check and, if necessary, correct these modifications and connections.

On request, Sartorius will provide information on the minimum operating specifications (in accordance with the Standards listed above for defined immunity to interference).

Council Directive 73/23/EEC “Electrical Equipment Designed for Use within Certain Voltage Limits”

Applicable European Standards:

EN 60950

Safety of information technology equipment including electrical business equipment

EN 61010

Safety requirements for electrical equipment for measurement, control and laboratory use

Part 1: General requirements

If you use electrical equipment in installations and under ambient conditions requiring higher safety standards, you must comply with the provisions as specified in the applicable regulations for installation in your country.

Weighing Instruments for Use in Legal Metrology: Directive 90/384/EEC “Non-automatic Weighing Instruments”

This Directive regulates the determination of mass in legal metrology.

For the respective Declaration of Conformity for weighing instruments that have been verified by Sartorius for use as legal measuring instruments and that have an EC Type-Approval Certificate, see page 88.

This Directive also regulates the performance of the EC verification by the manufacturer, provided that an EC Type-Approval Certificate has been issued and the manufacturer has been accredited by an officer or a Notified Body registered at the Commission of the European Community for performing such verification.

The legal basis allowing Sartorius to perform EC verification is constituted by the EC Council Directive No. 90/384/EEC on non-automatic weighing instruments that has been in effect since January 1, 1993, in the Internal Market as well as by the Certificate of Accreditation of the Sartorius AG Quality Management System issued by the Metrology Department of the Regional Administration Office of Lower Saxony, Germany (“Niedersächsisches Landesverwaltungsamt -Eichwesen”) on February 15, 1993.

For information on the **CE** mark on Sartorius equipment and legal regulations currently applicable in your country, and to obtain the names of the persons to contact, please ask your local Sartorius office, dealer or service center.

DECLARATION OF TYPE CONFORMITY to Directive No. 90/384/EEC

This declaration is valid for non-automatic electromechanical weighing instruments for use in legal metrology. These weighing instruments accepted for legal metrological verification have an EC Type-Approval Certificate. The model(s) concerned is(are) listed below along with the respective type, accuracy class, and number of the EC Type-Approval Certificate:

Model	Type	Accuracy Class	EC Type-Approval Certificate No.
EA...LOCE	DS BH 300	III	D98-09-013
EB...LOCE	DS BH 300	III	D98-09-013
EA...LOCE	DN BH 300	III	D98-09-013
EB...LOCE	DN BH 300	III	D98-09-013
EA...LOCE	DQ BH 300	III	D98-09-013
EB...LOCE	DQ BH 300	III	D98-09-013

SARTORIUS AG declares, at its sole responsibility, that its weighing instrument types comply with the regulations of the Council Directive for Non-Automatic Weighing Instruments, No. 90/384/EEC of 20 June 1990; the associated European Standard "Metrological aspects of non-automatic weighing instruments," No. EN 45501; the amended, currently valid versions of the national laws and decrees concerning legal metrology and verification in the Member States of the European Union, the EU, and the Signatories of the Agreement on the European Economic Area, which have adopted this Council Directive into their national laws; and with the requirements stipulated on the Type-Approval Certificate for verification. This Declaration of Type Conformity is valid only if the ID label on the weighing instrument has the CE mark of conformity and the green metrology sticker with the stamped letter 'M' (the two-digit number in large print stands for the year in which the mark has been affixed):

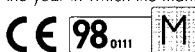

If these marks are not on the ID label, this Declaration of Type Conformity is not valid. Validity can be obtained, for example, by submitting the weighing instrument for final action to be taken by an authorized representative of SARTORIUS AG.

The period of validity of this Declaration of Type Conformity shall expire upon any tampering with, repair or modification of this weighing instrument or, in some Member States, on the date of expiration.

The operator of this weighing instrument shall be responsible for obtaining an authorized renewal of the verification, such as subsequent or periodic verification, of the weighing instrument for use as a legal measuring instrument.

Signed in Goettingen on this day of May 11, 1998

SARTORIUS AG
37070 Goettingen
Germany

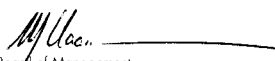
Board of Management
(Dr. Claassen)

Head of Technical Operations
Weighing Technology Division
(Dr. Maaz)

QAW-113-2/02.96
P103E500

Physikalisch-Technische Bundesanstalt

Braunschweig und Berlin

PTB



EG-Bauartzulassung

EC type-approval certificate

Zulassungsinhaber:

issued to:

Sartorius AG
Weender Landstraße 94-108
37075 Göttingen
Deutschland

Rechtsbezug:

in accordance with:

§ 13 des Gesetzes über das Meß- und Eichwesen (Eichgesetz)
vom 23. März 1992 (BGBl. I S. 711)
Council Directive: 90/384/EEC, amended by 93/68/EEC

Bauart:

In respect of:

Nonst selbsttätige elektromechanische Waage
Nonautomatic electromechanical weighing instrument
DS BH 300, DN BH 300, DQ BH 300
Genauigkeitsklasse **(II)**
Max 1 kg ... 180 kg, Anzahl der Eichwerte: $n \leq 3600$

Zulassungsnummer:

Approval number:

D98-09-013

Gültig bis:

Valid until:

23.04.2008

Anzahl der Seiten:

Number of pages:

8

Geschäftszeichen:

Reference No.:

1.14 - 98012792

Benannte Stelle:

Notified Body:

0102

Im Auftrag

By order

Brandes



Braunschweig, 24.04.1998

Siegel

Seal

Index

	Page		Page
Accessories	80	Net weight: toggling	39
Application programs	19	NetTotal (2nd tare memory)	27
Auto Print	58	Operating design	5
Auto zero	64	Operating menu (overview)	64
Averaging	41	Operating the scale	14
Basic weighing function	14	Options (Accessories)	80
Cabling diagram	60	Pin assignment chart	59
Calculation by a factor	33	Practical use	2
Calibration/adjustment	17	Printing: manual/automatic	67
Care and maintenance	70	Printout format	67
CE marking	82, 85	Recycling the packaging	71
Cleaning the scale	70	Repairs	70
Configuring the scale	61	Safety inspection	71
Connecting AC power	12	Safety precautions	4, 12
Contents	3	Second tare memory	27
Counting	20	Setting parameters in the menu	61
Data interface	50	Software handshake	57
Data output format	51 f.	Specifications	74 f.
Data output functions	45	Stability range	64
Description of the keys	73	Taring	14, 17, 27
Dimensions	79	Toggle:	
Display	6, 45 f.	between gross/net weights	39
Equipment supplied	10	between weight units	23
Error codes	68	Totalizing	36
Factory settings	62	Unit indicator	7, 23
Filter adaptation	63	Universal remote switch	81
General view of the scale	72	Unpacking the scale	10
Getting started	10	Warmup time	13
Gross weight: toggling	39 f.	Warranty	10
Handshake mode	57, 67	Weighing in percent	30
Installation instructions	11	Weight unit: toggling	23
Keys: description of	73	Weight units	25, 66
Menu (overview)	64	Zeroing the scale, scale set to zero	14, 17

Sartorius AG

✉ 37070 Goettingen, Germany

🏠 Weender Landstrasse 94-108, 37075 Goettingen, Germany

☎ (+49/551) 308-0, 📠 (+49/551) 308-289

Internet: <http://www.sartorius.com>

Copyright by Sartorius AG, Goettingen, Germany.
All rights reserved. No part of this publication
may be reprinted or translated in any form or by any means
without the prior written permission of Sartorius AG.

The status of the information, specifications and
illustrations in this manual is indicated by the date
given below. Sartorius AG reserves the right to
make changes to the technology, features,
specifications and design of the equipment
without notice.

Status: February 2000, Sartorius AG, Goettingen, Germany

Printed in Germany on paper that has been bleached
without any use of chlorine · W399-A00.Economy Express e · KT
Publication No.: WEA6002-e00023

sartorius