

Paperless Recording System

PAPERLESS RECORDER

(built-in input modules)

Functions & Features

- 100 msec. storing rate
- Data stored in CF Cards
- CF card slot accessible at the front
- 'Quick Setup' helps you to start and program the recorder
- Real time monitor at the host PC via Ethernet
- Dedicated application software to view and analyze the data
- 5.5 inch TFT LCD display
- Touch panel operation
- IP65 front panel

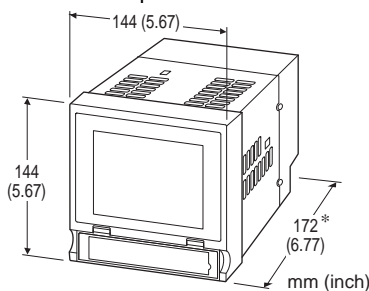

*195 (7.68) with the 73VR2108, 73VR2110 and 73VR2112.



MODEL: 73VR21[1]-[2]-[3]

ORDERING INFORMATION

- Code number: 73VR21[1]-[2]-[3]
- Specify a code from below for each [1] through [3].
(e.g. 73VR2102-E-M2)

[1] NO. OF CHANNELS

- 02: 2-point inputs
- 04: 4-point inputs
- 06: 6-point inputs
- 08: 8-point inputs
- 10: 10-point inputs
- 12: 12-point inputs

[2] LANGUAGE

- N: Japanese
- E: English

[3] POWER INPUT

AC Power

M2: 100 - 240 V AC (Operational voltage range 85 - 264 V, 47 - 66 Hz)

DC Power

R: 24 V DC

(Operational voltage range 24 V \pm 10 %, ripple 10 %p-p max.)

CAUTION

With 100 msec. storing rate, measured value may be susceptible to inaccuracies due to the fast update cycle. If this is the case, please choose 500 msec. or slower rate.

RELATED PRODUCTS

- Resistor module (model: REM3-250)
- CF Card

A CF Card is required to store data in the 73VR21xx. M-System will not guarantee the product's described performance if a CF Card other than purchased from M-System, or specified below, is used.

1. Manufacturer: Hagiwara Sys-Com

Model No.: MCF10P-xxxxS

Capacity: 128 MB through 1 GB

(Alternative)

Manufacturer: Hagiwara Sys-Com

Model No.: CFI-xxxxDG

Capacity: 128 MB through 1 GB

2. Manufacturer: Apacer Technology

Model name: CFC III

Model No.: AP-CFxxxxE3ER-ETNDNR

Part No.: 81.2A010.1H10C (256 MB)

81.2B010.1H10C (512 MB)

81.2E010.1H10C (1 GB)

Capacity: 256 MB through 1 GB

PACKAGE INCLUDES...

- 73VR Application Software CD (model: 73VRPAC2)
- Mounting brackets (two)

GENERAL SPECIFICATIONS

Construction: Panel flush mounting

Degree of protection: IP65; applicable to the front panel of the recorder with single mounting according to the specified panel cutout

Connection

Power input, signal input, trigger input, alarm output:

M3 screw terminal (torque 0.5 N·m)

Recommended solderless terminal: Refer to the drawing on the end of this section (unit: mm (inch)).

Applicable wire size: 0.3 to 0.75 mm²

Screw terminal: Nickel-plated steel

Materials

Enclosure: Steel

Bezel: Flame-resistant resin (black)

Front filter: Transparent resin

Isolation: Input 1 to input 2 to input 3 to input 4 to input 5 to input 6 to input 7 to input 8 to input 9 to input 10 to input 11 to input 12 to trigger input to alarm output to power input to FG to Ethernet

Burnout for T/C and RTD input: Upscale, Downscale or No burnout selectable

Select 'No Burnout' to minimize the measuring errors caused by the sensor/wire resistance and the burnout sensing current.

With RTD input, the signal may go transiently to the opposite direction from the burnout setting.

With DC input, the burnout setting is ignored and the burnout sensing current is cancelled.

Cold junction compensation (CJC) for T/C input: CJC can be enabled or disabled per each channel.

CJC sensor attached to Input 1 and Input 7* terminals. (Input 7 for the 73VR2108, 73VR2110 and 73VR2112)

Operating mode setting: Application software; burnout type, cold junction compensation, line noise frequency, A/D conversion mode setting available

Line noise filter: NMNR ratio to the line frequency and its harmonic contents can be optimized. Factory set to 50/60 Hz mode for use with both frequencies.

Select either frequency for the most effective result.

A/D conversion mode: Fast, Medium or Slow selectable.

With Slow setting, data fluctuations are minimized with limited sampling time (speed).

With Fast setting, sampling time (speed) can be high through data fluctuations increase.

■ INTERFACE

Ethernet: 10BASE-T / 100BASE-TX automatically switched; Conforms to IEEE 802 (10BASE-T) or IEEE 802.3 (100BASE-TX)

IP address: 192.168.0.1 (factory default setting)

Subnet mask: 255.255.255.0 (factory default setting)

Default gateway: None (factory default setting)

CF Card slot: Type I; for use with the cards' operating voltage 3.3 V

USB: Conforms to Version 1.1

■ DISPLAY

Display device: 5.5-inch TFT LCD

Display colors: 256

Resolution: 320 × 240 pixels

Pixel pitch: 0.12 × 0.35 mm

Note: The backlight can be replaced in M-System factory.

The LCD must be replaced at the same time.

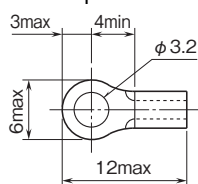

INPUT SPECIFICATIONS

• DC Voltage

Input resistance: 900 kΩ min.

Excluding the case in which, with range setting other than ±12 V, ±6 V or ±3 V, a voltage exceeding ±1.3 V is applied.

Input range: ±60 mV, ±125 mV, ±250 mV, ±500 mV, ±1000 mV, ±3 V, ±6 V, ±12 V

■ THERMOCOUPLE

Input resistance: 900 kΩ minimum

Input type: (PR), K (CA), E (CRC), F (IC), T (CC), B (RH), R, S, C (WRe 5-26), N, U, L, P (Platinel II)

Burnout sensing

Upscale: ≤ 130 nA

Downscale: ≤ 220 nA

No burnout: ≤ 10 nA

Burnout sensing time

K, E, J, N, L, P (upscale): ≤ 20 seconds

Others: ≤ 10 seconds

■ RTD (3-wire)

Excitation: 1.25 V / (1.25 kΩ + load resistance across the terminals A - C); 1.00 mA with 10 Ω across A

- C; 0.55 mA with 1000 Ω across A - C

Allowable leadwire resistance: 20 Ω per wire

Input type: Pt 100 (JIS '89), Pt 100 (JIS '97, IEC), Pt 200, Pt 300, Pt 400, Pt 500, Pt 1000, Pt 50Ω (JIS '81), JPt 100 (JIS '89), Ni 100, Ni 120, Ni 508.4Ω, Ni-Fe 604, Cu 10 @ 25°C

Burnout sensing

Upscale or Downscale: ≤ 130 nA

No burnout: ≤ 10 nA

Burnout sensing time: ≤ 10 seconds

■ TRIGGER INPUT: Dry contact; detected ON at ≤ 0.8 V

Voltage across the terminals: ≤ 2.5 V

Current across the terminals: ≤ 4.0 mA

■ ANALOG INPUT UPDATE CYCLE

LINE NOISE FILTER FREQ.	A/D CONVERSION (sec)			100 ms RATE
	MEDIUM*1	SLOW	FAST	
50 Hz	0.39	0.54	0.27	0.095
50/60 Hz*1	0.37	0.50	0.25	
60 Hz	0.34	0.46	0.23	

Multiplied by two (2) for RTD and potentiometer input.

*1. Standard setting

OUTPUT SPECIFICATIONS

■ **ALARM OUTPUT:** Photo MOSFET relay (no polarity);
 $\leq 50 \Omega$ at ON, $\geq 1 \text{ M}\Omega$ at OFF; OFF when not powered
Peak load voltage: 50 V max.
Continuous load current: 50 mA max.
Peak load current: 300 mA max. (≤ 0.1 sec.)

INSTALLATION

Power Consumption

•AC Power input:

Approx. 25 VA at 100 V
 Approx. 35 VA at 240 V

•DC Power input: Approx. 11 W or 460 mA

Operating temperature: 0 to 50°C (32 to 122°F)

Display quality (e.g. decreased contrast) may deteriorate when the recorder is used for a long time in an environment exceeding 50°C. However, it is only a temporary phenomenon. When the recorder is back in normal temperature, full legibility is recovered. No damage in performance.

Operating humidity: 30 to 85 %RH (non-condensing)

Allowable dust particles: 0.1 mg/m² (no conductive particles)

Corrosive gas: Not allowed

Mounting: Panel flush mounting

Panel cutout dimensions: 137 × 137 mm (5.39" × 5.39")

Weight

73VR2102, 73VR2104, 73VR2106: 2.3 kg (5.1 lbs)

73VR2108, 73VR2110, 73VR2112: 2.4 kg (5.3 lbs)

Caution: Use of UPS (switching time: without delay, output: sine waveforms) is recommended to prevent data loss or CF card damage by a loss of power during recording.

PERFORMANCE

Accuracy: See Tables 1 through 3.

Cold junction compensation error: (°C)

$\leq \pm[1.0 + |\text{Ambient Temp.} - 25| \times 0.04]$

(in stable ambient temperature; e.g. $\pm 1.4^\circ\text{C}$ at 15°C and 35°C)

Applicable with balanced terminal temperature.

Error will increase by imbalances caused by direct mounting of the REM3 to the terminals.

Temp. coefficient: See Table 4.

Response time

DC of ± 1000 mV or narrower ranges or T/C:

$\leq [\text{Sampling Time} + 0.3 \text{ sec.}] (0 - 90 \%)$

DC of ± 3 V or wider ranges:

$\leq [\text{Sampling Time} + 0.5 \text{ sec.}] (0 - 90 \%)$

RTD: $\leq [\text{Sampling Time} + 0.3 \text{ sec.}] (0 - 90 \%)$

Calendar clock accuracy: Monthly deviation 3 minutes at 25°C

Insulation resistance: $\geq 100 \text{ M}\Omega$ with 500 V DC

(input 1 to input 2 to input 3 to input 4 to input 5 to input 6 to input 7 to input 8 to input 9 to input 10 to input 11 to input 12 to trigger input to alarm output to power input to FG to Ethernet)

Dielectric strength: 500 V_{peak} @ 1 minute

(input 1 to input 2 to input 3 to input 4 to input 5 to input 6 to input 7 to input 8 to input 9 to input 10 to input 11 to input 12 to trigger input to alarm output to power input or FG)

Peak value including both AC and DC (e.g. 354 V AC with 0 V DC).

Nominal withstand voltage between I/O (analog input, trigger input and alarm output) and power input is described 500 V peak. However, as far as FG terminal is appropriately grounded, no dielectric breakdown will occur between I/O (with or without grounding) and other terminals when 2000 V AC is applied between FG and power input.

AC power input: 2000V AC @ 1 minute (power input to FG or Ethernet) 500 V AC @ 1 minute (FG to Ethernet)

DC power input: 1250 V AC @ 1 minute (power input to FG or Ethernet) 500 V AC @ 1 minute (FG to Ethernet)

Line noise normal mode rejection: ≥ 100 dB

Magnitude of the effects of normal mode 50/60 Hz noise, with the most appropriate line noise filter frequency setting. Each input circuit has a CR filter of sufficient large time constant so that there will be little effect of line noise such as 500 mV AC superposed on a thermocouple or ± 60 mV input.

Common mode noise rejection

Magnitude of the effects of voltages applied across the terminal C and the ground terminal when there is no potential difference among all the C terminals.

DC: N/A

AC, ± 3 V, ± 6 V, ± 12 V: Approx. 86 dB

AC, other ranges: Approx. 120 dB

Common mode noise rejection between channels

Magnitude of the effects of DC/50/60 Hz voltages applied across the terminals C of the present and the last scanned channels.

DC, ± 3 V, ± 6 V, ± 12 V: Approx. 100 dB

DC, other ranges: Approx. 120 dB

AC, ± 3 V, ± 6 V, ± 12 V: Approx. 86 dB

AC, other ranges: Approx. 106 dB

STANDARDS & APPROVALS

CE conformity:

EMC Directive (2004/108/EC)

EMI EN 61000-6-4

EMS EN 61000-6-2

Low Voltage Directive (2006/95/EC)

EN 61010-1

Installation Category II

Pollution Degree 2

Max. operating voltage 300 V

Input 1 or 2 or 3 or 4 or 5 or 6 or 7 or 8 or 9 or 10 or 11 or

12 to power to FG or Ethernet: Reinforced insulation

Input 1 to 2 to 3 to 4 to 5 to 6 to 7 to 8 to 9 to 10 to 11 to 12

to trigger input to alarm output: Operational insulation

INPUT TYPE, RANGE, ACCURACY & TEMPERATURE COEFFICIENT

*Accuracy: Applicable with the common mode voltage 0V between C terminals of all channels and between C terminal of each channel and FG terminal.

The effects by the following factors are excluded: Fast A/D conversion mode; temperature drift with the REM3 directly mounted to the I/O terminals; wire resistance; burnout sensing current with upscale/downscale settings. With 100 msec. storing rate, measured value may be susceptible to inaccuracies due to the fast update cycle. If this is the case, please choose 500 msec. or slower rate.

Table 1. DC Voltage Input

INPUT RANGE	ACCURACY (mV)
±60mV	±0.05
±125mV	±0.07
±250mV	±0.13
±500mV	±0.3
±1000mV	±0.5
±3V	±3
±6V	±5
±12V	±10

Table 2-1. Thermocouple Input, Celsius

T/C	USABLE RANGE (°C)	CONFORMANCE RANGE (°C)	ACCURACY (°C)
(PR)	0 to 1770	400 to 1770	±4.6
K (CA)	-270 to +1370	0 to 1370	±1.5
E (CRC)	-270 to +1000	0 to 1000	±0.8
J (IC)	-210 to +1200	0 to 1200	±1.0
T (CC)	-270 to +400	0 to 400	±1.3
B (RH)	100 to 1820	700 to 1820	±7.2
R	-50 to +1760	400 to 1760	±4.8
S	-50 to +1760	400 to 1760	±5.3
C (WRe 5-26)	0 to 2320	0 to 2320	±4.9
N	-270 to +1300	0 to 1300	±1.9
U	-200 to +600	0 to 600	±1.3
L	-200 to +900	0 to 900	±1.0
P (Platinel II)	0 to 1395	0 to 1395	±1.7

Table 2-2. Thermocouple Input, Fahrenheit

T/C	USABLE RANGE (°F)	CONFORMANCE RANGE (°F)	ACCURACY (°F)
(PR)	32 to 3218	752 to 3218	±8.3
K (CA)	-454 to +2498	32 to 2498	±2.7
E (CRC)	-454 to +1832	32 to 1832	±1.5
J (IC)	-346 to +2192	32 to 2192	±1.8
T (CC)	-454 to +752	32 to 752	±2.4
B (RH)	212 to 3308	1292 to 3308	±13.0
R	-58 to +3200	752 to 3200	±8.7
S	-58 to +3200	752 to 3200	±9.6
C (WRe 5-26)	32 to 4208	32 to 4208	±8.9
N	-454 to +2372	32 to 2372	±3.5
U	-328 to +1112	32 to 1112	±2.4
L	-328 to +1652	32 to 1652	±1.8
P (Platinel II)	32 to 2543	32 to 2543	±3.1

Remark 1) Measuring accuracy at 50µV emf.

Remark 2) CJC error is not included.

Table 3-1. RTD Input, Celsius

RTD	USABLE RANGE (°C)	ACCURACY	
		at ≤ 0°C	at ≥ 0°C
Pt 100 (JIS '97, IEC)	-200 to +850	±0.4°C	±[0.4°C + Measured Value × 0.1%] (±1.3°C at 850°C)
Pt 200	-200 to +850	±0.3°C	±[0.3°C + Measured Value × 0.17%] (±1.8°C at 850°C)
Pt 300	-200 to +850	±[0.4°C + Measured Value × 0.08%] (±0.3°C at -200°C)	±[0.4°C + Measured Value × 0.21%] (±2.2°C at 850°C)
Pt 400	-200 to +850	±[0.4°C + Measured Value × 0.11%] (±0.2°C at -200°C)	±[0.4°C + Measured Value × 0.21%] (±2.2°C at 850°C)
Pt 500	-200 to +850	±[0.4°C + Measured Value × 0.13%] (±0.2°C at -200°C)	±[0.4°C + Measured Value × 0.26%] (±2.6°C at 850°C)
Pt 1000	-200 to +850	±[0.4°C + Measured Value × 0.15%] (±0.1°C at -200°C)	±[0.4°C + Measured Value × 0.4%] (±3.8°C at 850°C)
Pt 100 (JIS '89)	-200 to +660	±0.4°C	±[0.4°C + Measured Value × 0.1%] (±1.1°C at 660°C)
JPt 100 (JIS '89)	-200 to +510	±0.4°C	±[0.4°C + Measured Value × 0.1%] (±1.0°C at 510°C)
Pt 50Ω (JIS '81)	-200 to +649	±0.5°C at ≤160°C, ±[0.4°C + Measured Value × 0.1%] at ≥160°C (±1.1°C at 649°C)	
Ni 100	-80 to +260	±0.3°C	
Ni 120	-80 to +260	±0.3°C	
Ni 508.4Ω	-50 to +280	±[0.25°C + Measured Value × 0.06%] (±0.3°C at -50°C, ±0.5°C at 280°C)	
Ni-Fe 604	-200 to +200	±0.9°C at -200°C, ±0.6°C at -150°C, ±0.5°C at ±100°C, ±0.7°C at 200°C	
Cu 10 @25°C	-50 to +250	±1.2°C	

Remark 1) The lower the temperature range, the better the accuracy is for Pt 300, Pt 400, Pt 500, Pt 1000 and Ni 508.4Ω. 'Measured Value' in the equations is not an absolute value. Include the minus sign when calculating accuracies.

Table 3-1. RTD Input, Fahrenheit

RTD	USABLE RANGE (°F)	ACCURACY	
		at ≤ 32°F	at ≥ 32°F
Pt 100 (JIS '97, IEC)	-328 to +1562	±0.8°F	±[0.72°F + Measured Value × 0.1%] (±2.4°F at 1562°F)
Pt 200	-328 to +1562	±0.6°F	±[0.54°F + Measured Value × 0.17%] (±3.3°F at 1562°F)
Pt 300	-328 to +1562	±[0.72°F + Measured Value × 0.08%] (±0.5°F at -328°F)	±[0.72°F + Measured Value × 0.21%] (±4.0°F at 1562°F)
Pt 400	-328 to +1562	±[0.72°F + Measured Value × 0.11%] (±0.4°F at -328°F)	±[0.72°F + Measured Value × 0.21%] (±4.0°F at 1562°F)
Pt 500	-328 to +1562	±[0.72°F + Measured Value × 0.13%] (±0.3°F at -328°F)	±[0.72°F + Measured Value × 0.26%] (±4.7°F at 1562°F)
Pt 1000	-328 to +1562	±[0.72°F + Measured Value × 0.15%] (±0.2°F at -328°F)	±[0.72°F + Measured Value × 0.4%] (±6.9°F at 1562°F)
Pt 100 (JIS '89)	-328 to +1220	±0.8°F	±[0.72°F + Measured Value × 0.1%] (±2.0°F at 1220°F)
JPt 100 (JIS '89)	-328 to +950	±0.8°F	±[0.72°F + Measured Value × 0.1%] (±1.7°F at 950°F)
Pt 50Ω (JIS '81)	-328 to +1200	±0.9°F at ≤320°F, ±[0.72°F + Measured Value × 0.1%] at ≥320°F (±1.9°F at 1200°F)	
Ni 100	-112 to +500	±0.6°F	
Ni 120	-112 to +500	±0.6°F	
Ni 508.4Ω	-58 to +536	±[0.45°F + Measured Value × 0.06%] (±0.4°F at -58°F, ±0.8°F at 536°F)	
Ni-Fe 604	-328 to +392	±1.7°F at -328°F, ±1.1°F at -238°F, ±0.9°F at ±212°F, ±1.3°F at 392°F	
Cu 10 @25°C	-58 to +482	±2.2°F	

Remark 1) The lower the temperature range, the better the accuracy is for Pt 300, Pt 400, Pt 500, Pt 1000 and Ni 508.4Ω. 'Measured Value' in the equations is not an absolute value. Include the minus sign when calculating accuracies.

Table 4. Temperature Coefficient

INPUT TYPE	TEMPERATURE COEFFICIENT	
DC Voltage	±[Nominal Input Range × 0.015%]/°C or ±[Nominal Input Range × 0.008%]/°F (e.g. ±0.018mV/°C with ±60mV range)	
Thermocouple	±[Accuracy / 3] °C/°C or ±[Accuracy / 3] °F/°F (e.g. ±0.27°C/°C with E thermocouple)	
RTD	at ≤ 0°C or 32°F	at ≥ 0°C or 32°F
Pt 100 (JIS '97, IEC)	±0.041°C/°C ±0.041°F/°F	±[0.041°C + Measured Value × 0.026%]/°C ±[0.041°F + Measured Value × 0.026%]/°F
Pt 200	±0.044°C/°C ±0.044°F/°F	±[0.044°C + Measured Value × 0.033%]/°C ±[0.044°F + Measured Value × 0.033%]/°F
Pt 300	±0.047°C/°C ±0.047°F/°F	±[0.047°C + Measured Value × 0.04%]/°C ±[0.047°F + Measured Value × 0.04%]/°F
Pt 400	±0.05°C/°C ±0.05°F/°F	±[0.05°C + Measured Value × 0.052%]/°C ±[0.05°F + Measured Value × 0.052%]/°F
Pt 500	±0.053°C/°C ±0.053°F/°F	±[0.053°C + Measured Value × 0.053%]/°C ±[0.053°F + Measured Value × 0.053%]/°F
Pt 1000	±[0.068°C + Measured Value × 0.025%]/°C ±[0.068°F + Measured Value × 0.025%]/°F	±[0.068°C + Measured Value × 0.087%]/°C ±[0.068°F + Measured Value × 0.087%]/°F
Pt 100 (JIS '89)	±0.041°C/°C ±0.041°F/°F	±[0.041°C + Measured Value × 0.024%]/°C ±[0.041°F + Measured Value × 0.024%]/°F
JPt 100 (JIS '89)	±0.041°C/°C ±0.041°F/°F	±[0.041°C + Measured Value × 0.023%]/°C ±[0.041°F + Measured Value × 0.023%]/°F
Pt 50 (JIS '81)	±0.039°C/°C ±0.039°F/°F	±[0.039°C + Measured Value × 0.021%]/°C ±[0.039°F + Measured Value × 0.021%]/°F
Ni 100	±0.028°C/°C ±0.028°F/°F	±[0.028°C + Measured Value × 0.01%]/°C ±[0.028°F + Measured Value × 0.01%]/°F
Ni 120	±0.028°C/°C ±0.028°F/°F	±[0.028°C + Measured Value × 0.01%]/°C ±[0.028°F + Measured Value × 0.01%]/°F
Ni 508.4Ω	±0.046°C/°C ±0.046°F/°F	±[0.046°C + Measured Value × 0.018%]/°C ±[0.046°F + Measured Value × 0.018%]/°F
Ni-Fe 604	±0.058°C/°C at ≤-200°C, ±0.043°C/°C at -150°C, ±0.04°C/°C at -100°C, ±[0.047°C + Measured Value × 0.023%]/°C at ≥0°C ±0.058°F/°F at ≤-328°F, ±0.043°F/°F at -238°F, ±0.04°F/°F at -148°F, ±[0.047°F + Measured Value × 0.023%]/°F at ≥32°F	
Cu 10 @25°C	±0.07°C/°C or ±0.07°F/°F	

APPLICATION SOFTWARE CD

■ 73VRPAC2 (included in the product package)

- 73VR21x Builder Software: Model 73VR21BLD

Used to configure parameters on the PC.

- Parameter configurations can be downloaded to the recorder via Ethernet.
- Present setting on the 73VR21x can be uploaded and displayed on the PC.
- Configuration files can be converted into CSV.

- 73VR Data Viewer: Model 73VRWV

Used to show and analyze recorded data on the PC.

- Data stored in the CF Card can be called up on the PC screen via the CF Card Reader.
- Data stored in the CF Card can be sent by FTP and called up on the PC screen.
- Various analyzing functions
- Data, alarm history and comment files can be converted into CSV.

- PC Recorder Software: Model MSR128-V6

- The 73VR21x data can be sampled and stored in real time via Ethernet by the MSR128-V6.

- Instruction Manuals

- 73VR21x users manual
- 73VR21BLD users manual
- 73VRWV users manual
- MSR128-V6 users manual

PC REQUIREMENTS (provided by the user)

• 73VR21x Builder Software: Model 73VR21BLD

OS	Windows XP SP2, SP3 or Windows Vista Business 32 bits or Windows 7 Professional 32 bits Note: Proper software functions may not be ensured under certain conditions.
Screen area	1024 by 768 pixels
CD-ROM drive	Windows supported CD-ROM drive is used to install the software programs.
Card reader	Used to read/write the CF Card
Mouse	Windows supported
LAN card	LAN card required to connect to Ethernet; 10BASE-T or 100BASE-T cable

• 73VR Data Viewer: Model 73VRWV

OS	Windows XP SP2, SP3 or Windows Vista Business 32 bits or Windows 7 Professional 32 bits Note: Proper software functions may not be ensured under certain conditions.
Screen area	1024 by 768 pixels or higher
Display color	65000 colors (16 bits)
Main memory (RAM)	512MB or higher recommended 2 GB recommended for Windows Vista Business 32 bits or Windows 7 Professional 32 bits
CD-ROM drive	Windows supported CD-ROM drive is used to install the software programs.
Card reader	Used to read/write the CF Card
Mouse	Windows supported (Certain functions of the 73VR may be compromised if the mouse's software driver is not Windows standard.)
LAN card	LAN card required to connect to Ethernet; 10BASE-T or 100BASE-T cable

• **PC Recorder Software: Model MSR128-V6**

	NORMAL MODE (storing rates ≥ 500 ms)	HIGH SPEED MODE (storing rates 100 / 200 ms)*1
PC	IBM PC/AT or compatible	
OS	Microsoft Windows XP SP1, SP2, SP3 or Windows Vista Business 32 bits or Windows 7 Professional 32 bits Note: Proper software functions may not be ensured under certain conditions.	
CPU	Pentium III 800 MHz or higher 1GHz higher for Windows Vista, Windows 7	Pentium IV 2.0 GHz or higher
Screen area	1024 by 768 pixels or better resolution	
Display color	65000 colors (16 bits)	
Video memory	2 MB minimum; 4 MB recommended	4 MB minimum
Main memory	256 MB recommended; 1 GB recommended for Windows Vista, Windows 7	512 MB recommended; 1 GB recommended for Windows Vista, Windows 7
Hard disk area	Use an internal hard disk. *2 Max. approx. 100 MB required per day.	Use an internal hard disk. *2 Max. approx. 500 MB required per day.
Printer	Use a printer for Windows. The programs use Standard System Fonts used in Windows. Use a printer driver for Standard System Fonts.	
CD-ROM drive	Used when installing the software program.	
Card reader drive	Used with devices which save data in a Compact Flash Card	
Communication port	RS-232C port (COM1 through COM5) supported LAN card	LAN card by Windows

*1. The 73VR1100 or the 73VR21x cannot be used in High Speed Mode.

*2. External (e.g. SCSI) devices may impair appropriate performance.

EXTERNAL VIEW

■ FRONT VIEW

• 73VR21x

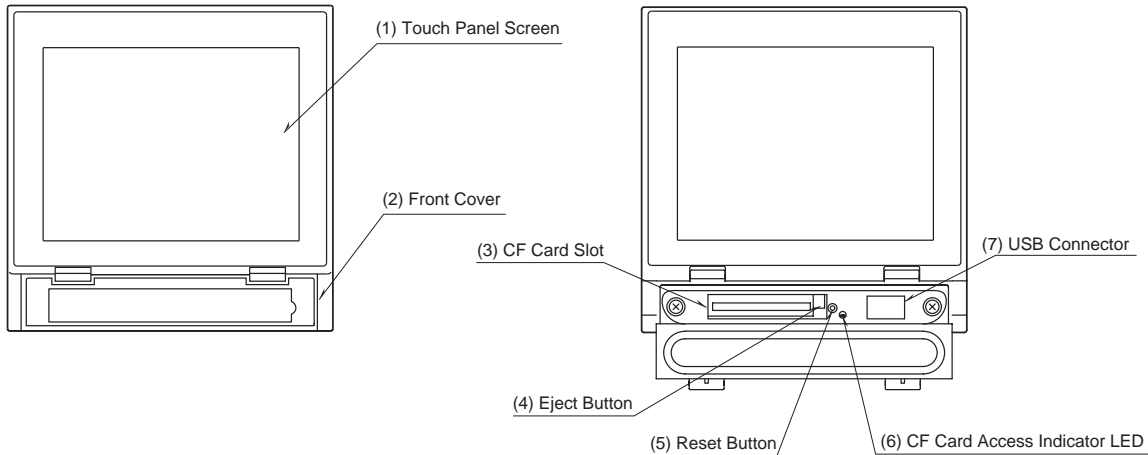

■ REAR VIEW

• 73VR2102, 73VR2104, 73VR2106

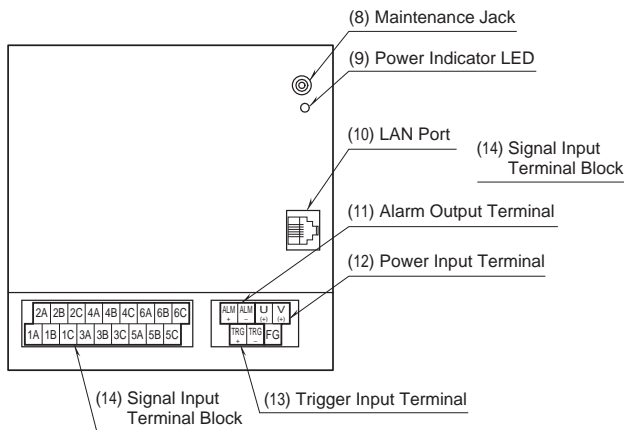

• 73VR2108, 73VR2110, 73VR2112

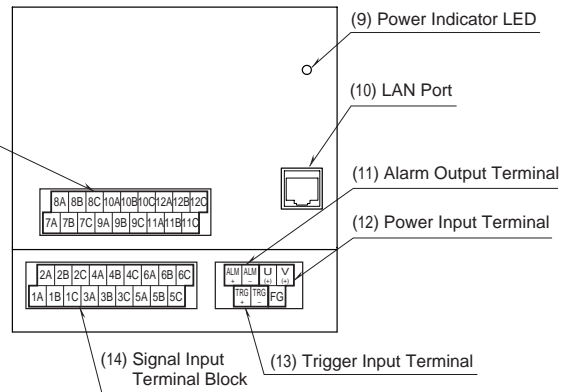

■ SIDE VIEW

• 73VR2108, 73VR2110, 73VR2112

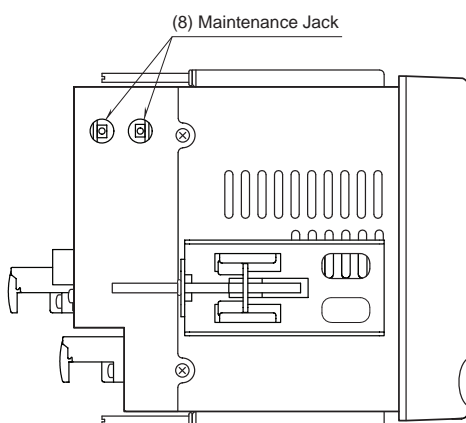

- (1) Touch Panel Screen
Trend chart and other data views and setup views are displayed.
- (2) Front Cover
Access to the CF Card Slot.
- (3) CF Card Slot
- (4) Eject Button
Used to retrieve the CF Card.
- (5) Reset Button
Used to restart the 73VR21x.
- (6) CF Card Access Indicator LED
Red light turns on during the CF Card is accessed.
- (7) USB Connector
Connect an USB ash-memory .
- (8) Maintenance Jack
Unused
- (9) Power Indicator LED
Light turns on while the power is supplied.
- (10) LAN Port
Connects the LAN cable (10BASE-T or 100BASE-TX)
- (11) Alarm Output Terminal
- (12) Power Input Terminal
- (13) Trigger Input Terminal
- (14) Signal Input Terminal Block

CONNECTION DIAGRAM

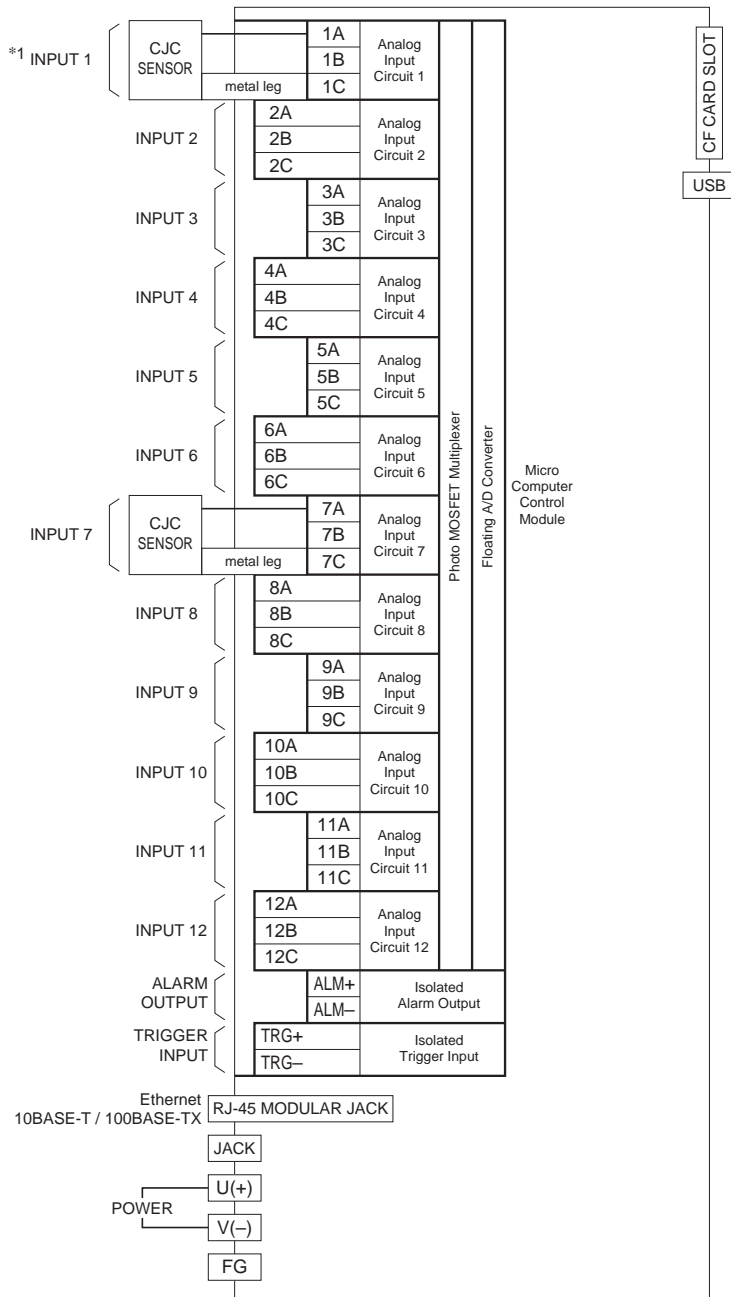

*1. Usable terminals depend upon the number of inputs.

Input Connection Examples

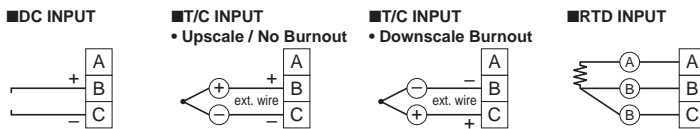

- Remark 1: In order to prevent instability in measured values caused by noise entering through the I/O terminals, grounding the signal shield to a most stable earth point in the environment is recommended.
- Remark 2: The smaller is common mode voltage (DC and AC) between C terminals and between C and FG, the better is measuring accuracy. Connecting between C terminals and if possible to FG will yield the best accuracy.
- Remark 3: Resistor modules (model: REM3-250) can be connected to 1A through 12C terminals to convert current inputs into voltage. However, it is not recommended when TC inputs are mixed because the heat developed on and around the REM3 affects the cold junction compensation performance. We recommend that REM3 be connected on a separate terminal board.
- Remark 4: When the internal temperature sensors are used for CJC, temperature imbalance around the terminal block affects greatly the CJC accuracy. In order to minimize such imbalance, do not use wires of large diameter which has large heat dissipation. Be sure to close the terminal cover. Do not expose the module directly in the line of wind from a cooling fan.

DIMENSIONS unit: mm (inch)

■ 73VR2102, 73VR2104, 73VR2106

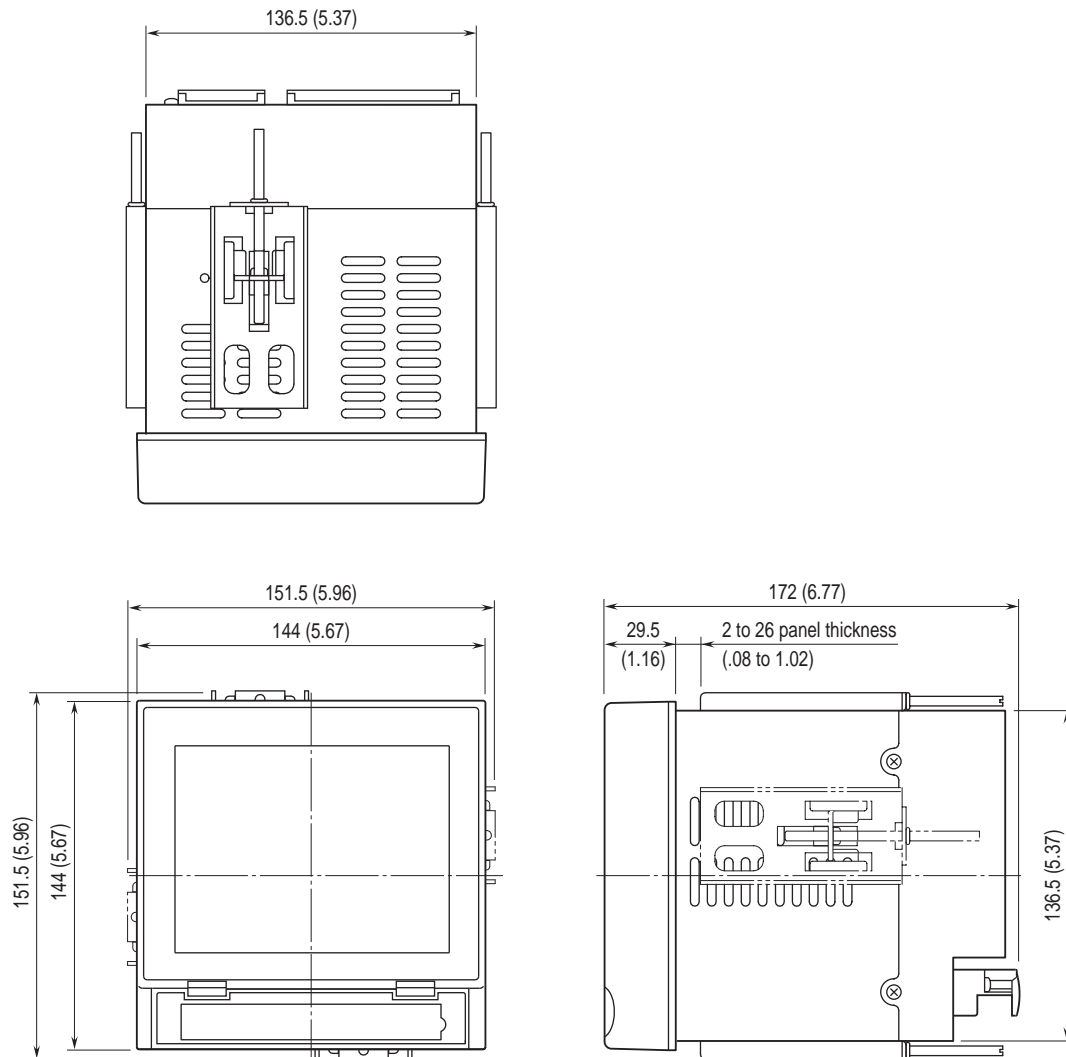

Attach the mounting bracket either on the top/bottom or on the sides.

■ 73VR2108, 73VR2110, 73VR2112

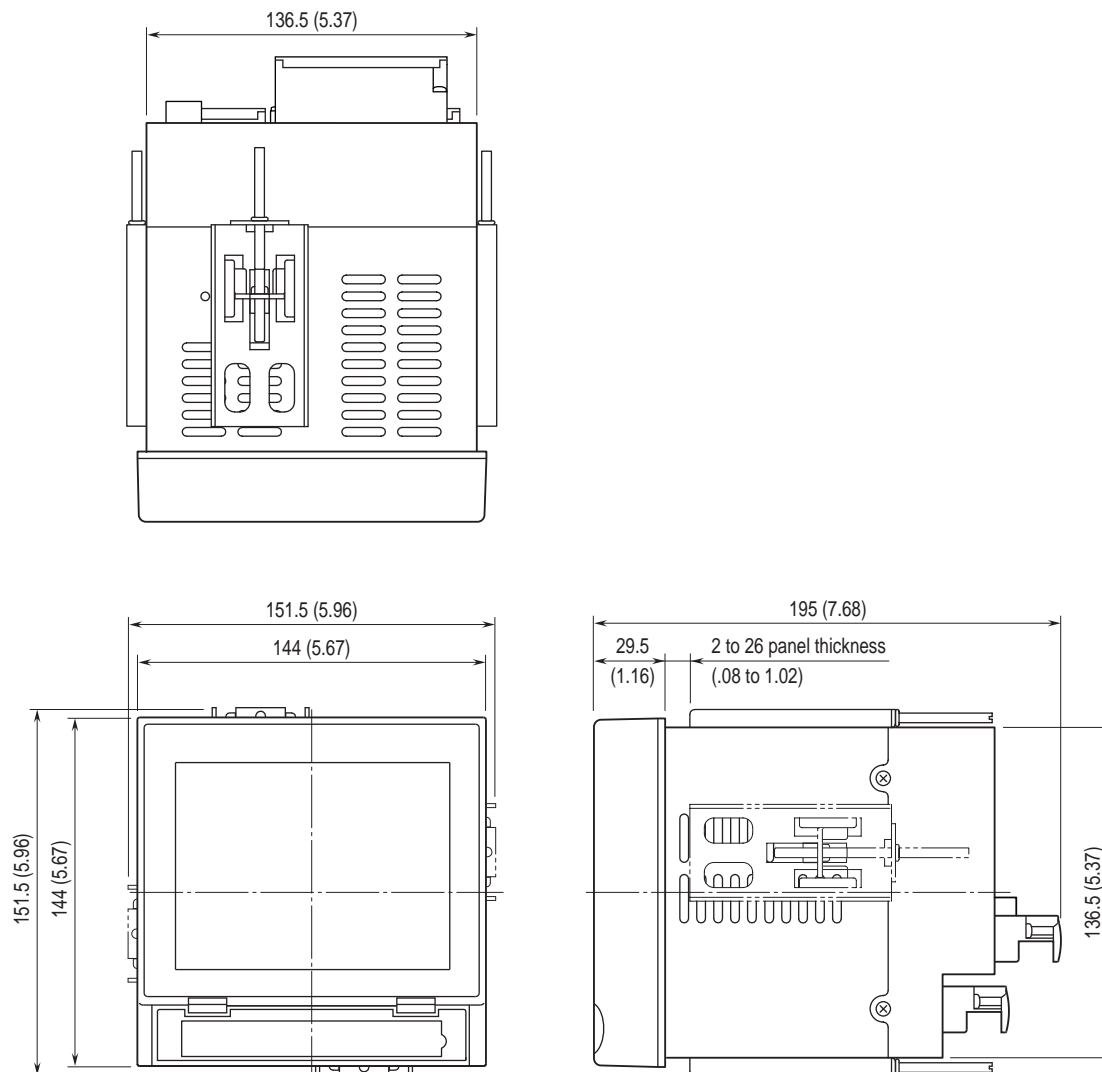

Attach the mounting bracket either on the top/bottom or on the sides.

PANEL CUTOUT (unit: mm)

Usable panel thickness: 2 - 26 mm (0.08" - 1.02")

■ SINGLE MOUNTING

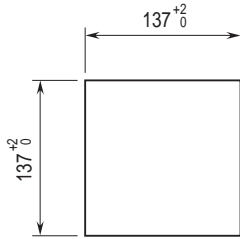

Number	L_0^{+2} (mm)
2	282
3	426
4	570
5	714
6	858
7	1002
8	1146
9	1290
10	1434
n	$(114 \times n) - 6$

Dimensional tolerance $\pm 3\%$ unless otherwise specified.
(± 0.3 mm for < 10 mm)

■ VERTICAL CLUSTERED MOUNTING (max. 3 units)

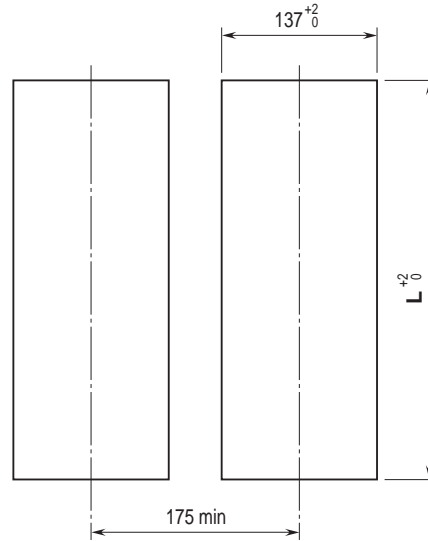

■ HORIZONTAL CLUSTERED MOUNTING

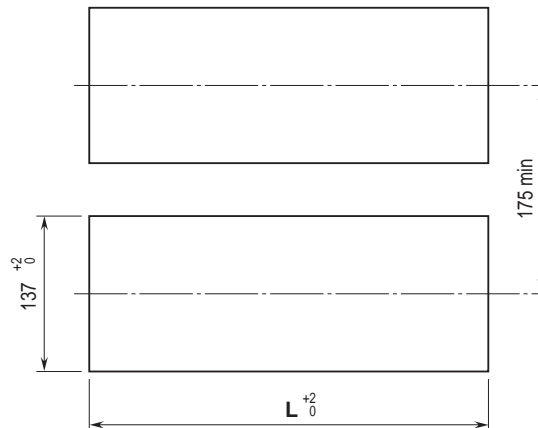

SOFTWARE FUNCTIONS

■ NUMBER OF INPUT PEN POINTS

- 73VR2102: 2 points
- 73VR2104: 4 points
- 73VR2106: 6 points
- 73VR2108: 8 points
- 73VR2110: 10 points
- 73VR2112: 12 points

■ INPUT SIGNALS

Analog: DC mV and voltage, thermocouple and RTD

Discrete: Trigger input (1 point)

■ DATA STORING METHOD

Normal: Recording is manually initiated and stopped. Data is continuously stored while the recording is on.

Auto: Recording is automatically initiated and stopped at a predefined time.

Event recording: The recorder detects an external event by trigger signal, and stores preset number of samples (max. 1200 respectively) before and after the moment of event.

Remote trigger: Data is automatically recorded while the external trigger condition (input) is true.

■ STORING RATE

0.1 (DC voltage input only) 0.5, 1, 2, 5, 10 sec., 1, 10 minutes

■ DATA STORAGE

Data file: Stores momentary values in the storing rate and their calculation result.

Alarm history file: Records time index information when alarms are triggered and reset.

Oldest data is overwritten with new data when the number of records reaches its limit.

Comment history file: Records comments written in trend

views with time index. Oldest data is overwritten with new data when the number of records reaches 1000 files.

Configuration file: Stores the 73VR21x setting.

File format: Binary

Oldest measured data is overwritten with new data or data recording is stopped when the card memory is full.

■ ALARM

• Analog Alarm

Alarm setpoints: Max. 4 points per channel

Alarm type: High / Low

Deadband: Set in engineering unit values

Output: 1 point at Alarm Output **TerminalStored**

information: Date/time of alarm events (trip and reset), Pen No., Tag Name and Alarm Message

Number of stored alarm events: Depends upon the CF Card capacity.

128 MB 250 events

256 MB 500 events

512 MB or 1 GB 1000 events

■ CALCULATION FUNCTIONS

Number of channels: 12 channels

Operations

Arithmetic: Addition/subtraction, Multiplication, Division

Logical: AND, OR, NOT, XOR

Mathematical: Square root extractor, Power

Accumulation: Analog accumulation

Filter: Moving average, First order lag

Hold: Peak (maximum) hold (tracking increasing signal),

Peak (minimum) hold (tracking decreasing signal)

F value: F value

Alarm: Alarm trip can be programmed for calculated results.

■ DATA DISPLAY FUNCTIONS

• Trend View

Chart direction: Perpendicular or horizontal

Number of pens displayed: 2, 4, 6, 8 per view

Number of display views: 4

Chart speed: Chart speed is described as number of pixels to plot single data sample. (pixel(s)/samples)

4, 1, 1/5, 1/32,

1/160 (not selectable with 100 msec. storing rate),

1/480 (not selectable with 100 msec. storing rate),

1/960 (not selectable with 100 msec. storing rate)

Display rate: 1 second

Pen thickness: Normal and wide

Digital indicator: Shows momentary value.

Alarm indicator: Shows alarm status of the channels displayed on the screen.

Comment: Shows comments entered manually.

Scale: Linear and square root;

Switchable to the engineering unit scale.

• Bargraph View

Bargraph direction: Perpendicular or horizontal

Number of pens displayed: 2, 4, 6, 8 per view

Number of display views: 4

Display rate: 1 second

Digital indicator: Shows momentary value.

Alarm indicator: Shows alarm status of the channels displayed on the screen.

Scale: Linear and square root;

Switchable to the engineering unit scale.

• Overview

Number of pens displayed: 2, 4, 6, 8, 16 per view

Number of display views: 13

Display rate: 1 second

Alarm indicator: Shows alarm status and date/time of the last alarm trip and reset for the channels displayed on the screen.

• Retrieve View

Number of pens displayed: 2, 4, 6, 8 per view

Number of display views: 4

Data search: Scrolling the chart, specifying a specific time index, or searching by maximum/minimum values.

Long span view: Retrieved data is thinned out so that a longer time span can be displayed on the chart.

• Alarm History View

Shows data stored in the alarm history file.

Number of displayed alarm events: 16

Number of display views: 1

Display update: Automatically updated by a new event

Data search: Scrolling the view or specifying a specific time index.

Jump: Scroll the view to an alarm event to show the relevant data on Retrieve View.

• Comment History View

Shows data stored in the comment history file.

Number of displayed alarm events: 16

Number of display views: 1

Data search: Scrolling the view or specifying a specific time index.

Jump: Scroll the view to a comment to show the relevant data on Retrieve View.

■ ETHERNET COMMUNICATION

• Dedicated Protocol

Real time communication: Transmits specific data to a host PC installed with the PC Recorder Software (model: MSR128).

FTP communication: Transmits data stored in the CF Card using the FTP protocol to a host PC by the 73VR Data Viewer (model: 73VRWV) installed in it. Data can be transmitted

even during recording.

Download, Upload: Software configurations created on the 73VR21x Configuration Builder (model:73VR21BLD) can be downloaded to the 73VR21x. The configuration set up on the 73VR21x can be uploaded and displayed on the 73VR21BLD.

- **Modbus Protocol**

Protocol: Modbus/TCP

Port No.: 502 (fixed)

IP address: Set on the recorder

Subnet mask: Set on the recorder

Default gateway: Set on the recorder

Max. number of 73VR21x connected simultaneously: 2

Supported Function Codes

CODE	NAME	FUNCTION
01	Read Coil Status	Reads DO
02	Read Input Status	Reads DI
04	Read Input Register	Reads Input Register
11	Fetch Communication Event Counter	Reads Status Word and Event Counter from Comm. Event Counter

Exception Response

CODE	NAME	FUNCTION
01	Illegal Function	Function Not supported
02	Illegal Data Address	Specified address does not exist

Supported Function Codes

	ADDR.	TYPE	NAME
Coil (0X)	1		Discrete output
Input Status (1X)	1		Trigger input
	3		Discrete input (73VR2102)
	5		Discrete input (73VR2104)
	7		Discrete input (73VR2106)
	9		Discrete input (73VR2108)
	11		Discrete input (73VR2110)
	13		Discrete input (73VR2112)
	14 – 25		Function data (discrete)
Input Register (3X)	1 – 24	F	Measured data (analog)
	25 – 48	F	Function data (analog)

■ **OTHER FUNCTIONS**

- **Operation Lockout**

With a password setting, unauthorized operations on the Trend View, Bargraph View and Overview can be locked out.

- **Data File Used Volume Information**

A bargraph with % indication is provided on the screen to show how much percent of the data file memory has been used up.

0 - 49 % used: Green bargraph

50 - 79 % used: Amber bargraph

80 - 100 % used: Red bargraph

- **Hot Swapping of the CF Card**

The CF Card is hot swappable: removable during data recording. However, there may be a slight disturbance in storing rate when the card is inserted.

- **Screen Saver**

The backlight is automatically turned off if the screen is untouched for a certain time period.

- **Bus Error Alert**

An alarm is output at Alarm Output Terminal in case of internal bus error.

- **Writing/Reading Setting**

The recorder's present setting can be stored in a USB flash-memory. Setting stored in the memory can be read in to the 73VR21x.

- **Hardware Setting**

Burnout, Cold junction compensation, AD conversion mode, line noise filter

- **Field Calibration**

■ STORABLE TIME DURATION IN 128MB CF CARD

STORING RATE	APPROXIMATE TIME DURATION					
	2 ch input	4 ch input	6 ch input	8 ch input	10 ch input	12 ch input
0.1 second	8 days 20 hours	5 days 18 hours	4 days 9 hours	3 days 10 hours	2 days 20 hours	2 days 10 hours
0.5 second	44 days 9 hours	28 days 22 hours	22 days 7 hours	17 days 17 hours	14 days 5 hours	12 days 4 hours
1 second	89 days 12 hours	57 days 20 hours	44 days 16 hours	34 days 3 hours	28 days 10 hours	24 days 9 hours
10 seconds	2 years 146 days	1 year 211 days	1 year 73 days	341 days 10 hours	284 days 12 hours	243 days 21 hours
1 minute	---	9 years 126 days	7 years 127 days	5 years 223 days	4 years 247 days	4 years 3 days

--- : Exceeds 10 years

Note 1) Data are calculated ones, and thus not guaranteed.

Note 2) Assuming 4 bytes per data per channel.

Note 3) A year is calculated as 365 days.

SYSTEM CONFIGURATION EXAMPLES

■ INDEPENDENTLY USED

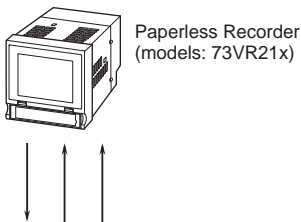

■ INTERFACING WITH A PC

• Reading Data from CF Card

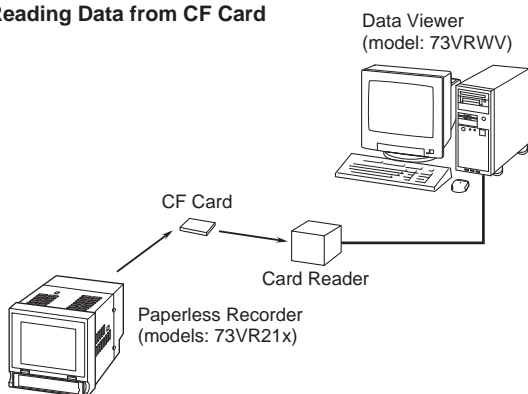

• Ethernet Connection

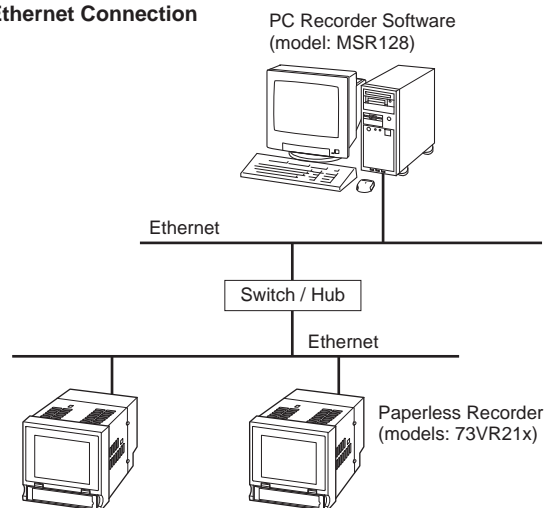

Note: It is recommended to connect the 73VR21x to the PC using straight cables via a switch/hub on the Ethernet.



Specifications are subject to change without notice.