

Plug-in Signal Conditioners K-UNIT

TEMPERATURE INPUT LIMIT ALARM

(digital adjustments; dual alarm trip)

Functions & Features

- Providing relay contact closures at preset DC input levels
- Dual (Hi/Lo) trip
- Front digital displays
- Programmable with front keys

Typical Applications

- Various alarm applications

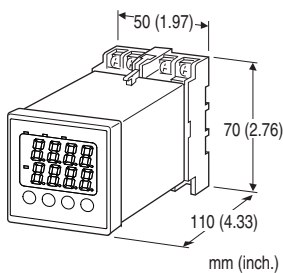

MODEL: KS2TR2-1-[1][2]

ORDERING INFORMATION

- Code number: KS2TR2-1-[1][2]
- Specify a code from below for each [1] and [2].
(e.g. KS2TR2-1-R/UL/Q)
- Specify the specification for option code /Q
(e.g. /SET)

TEMPERATURE INPUT

Thermocouple input

K(CA), E(CRC), J(IC), T(CC), B(RH), R, S, P(Platinel II), C(WRe 5-26), N

RTD input

JPt 100 (JIS '89), Pt 100 (JIS '97, IEC)

OUTPUT

1: Relay; SPDT or transfer contact

[1] POWER INPUT

AC Power

M2: 100 - 240 V AC (Operational voltage range 85 - 264 V, 47 - 66 Hz)

DC Power

R: 24 V DC

(Operational voltage range 24 V ±10 %, ripple 10 %p-p max.)

[2] OPTIONS (multiple selections)

Standards & Approvals

blank: CE marking

/UL: UL approval, CE marking

Other Options

blank: none

/Q: Option other than the above (specify the specification)

SPECIFICATIONS OF OPTION: Q

EX-FACTORY SETTING

/SET: Preset according to the Ordering Information Sheet
(No. ESU-3606)

GENERAL SPECIFICATIONS

Construction: Panel flush mounting, plug-in

Connection: M3.5 screw terminals

Housing material: Flame-resistant resin (gray)

Isolation: Input to SET1 to SET2 to power

Time constant for the input filter (P-dF): 5.0 to 900.0 sec. (0 - 63 %)

Alarm relay switching delay time (P-d1, P-d2): 1 to 10 sec.; programmable independently for each setpoint

Programming: Front key

Setpoint adjustment (ST1, ST2): -5 to +105 %; programmable independently for each setpoint

Deadband (hysteresis) (HYS1, HYS2): 0 - 102 %; programmable independently for each setpoint

Burnout: Upscale or downscale or no burnout

Cold junction compensation (CJM): ON or OFF; for thermocouple input only; CJC sensor incorporated

Power ON delay (P-d0): 0 to 20 sec.

Read rate: 0.5 sec.

Temperature unit (P-F): °C, °F

Alarm mode (P-A1, P-A2): Programmable independently for each setpoint; See Table below.

Param. Code (P-A1) (P-A2)	Alarm Modes			
	Trip Operation	Set Value	Latching Hold *	Relay & LED Behavior in Tripped Conditions
0	No alarm	–	–	–
1	High	Absolute Value	Without	LED ON Coil energized
2	Low	Absolute Value	Without	LED ON Coil energized
3	High	Absolute Value	With	LED ON Coil energized
4	Low	Absolute Value	With	LED ON Coil energized
5	High	Absolute Value	Without	LED ON Coil de-energized
6	Low	Absolute Value	Without	LED ON Coil de-energized
7	High	Absolute Value	With	LED ON Coil de-energized
8	Low	Absolute Value	With	LED ON Coil de-energized

*Without latching hold function, the unit is tripped upon starting operation when the unit is set to Low alarm.
With the function, the unit is NOT tripped until the temperature goes once above and then below the setpoint.

DISPLAY

Display: 4 digits of 10 mm (.39") height, 7-segment LED
Scaling range: -1999 to 9999 counts
Measured Value (PV)/Alarm (SET1) display: Red LEDs
Alarm (SET2) parameter display: Green LEDs
PV display at abnormal input: Over range or under range displayed
Front LEDs
Power indicator: Green LED turns on while the power is turned on.
Measured Value (PV) indicator: Green LED turns on when PV display is set.
Alarm SET1 indicator: Red LED turns on when the Alarm SET1 is in tripped conditions.
Alarm SET2 Indicator: Red LED turns on when the Alarm SET2 is in tripped conditions.
Engineering unit indication: Sticker label attached; °C, °F, etc.

INPUT SPECIFICATIONS

- **Thermocouple**
Thermocouple type and temperature range
 J (IC) : (0 to 400°C or 32 to 752°F)
 J (IC) : (0 to 800°C or 32 to 1472°F)
 K (CA) : (0 to 400°C or 32 to 752°F)
 K (CA) : (0 to 800°C or 32 to 1472°F)

K (CA) : (0 to 1200°C or 32 to 2192°F)
 R : (0 to 1600°C or 32 to 2912°F)
 B (RH) : (0 to 1800°C or 32 to 3272°F)
 S : (0 to 1600°C or 32 to 2912°F)
 T (CC) : (-199 to 200°C or -328 to 392°F)
 T (CC) : (-150 to 400°C or -238 to 752°F)
 E (CRC) : (0 to 800°C or 32 to 1472°F)
 E (CRC) : (-199 to 800°C or -328 to 1472°F)
 N : (0 to 1300°C or 32 to 2372°F)
 P (Platinel II) : (0 to 1300°C or 32 to 2372°F)
 C (WRe 5-26) : (0 to 2300°C or 32 to 4172°F)

Input resistance: ≥ 1 MΩ

Burnout sensing: Approx. 0.3 μA

■ RTD

RTD type and temperature range:

Pt 100 (JIS '97, IEC): (-150 to +850°C or -238 to +1562°F)

JPt 100 (JIS '89): (-150 to +600°C or -238 to +1112°F)

Sensing current: Approx. 0.3 mA

Maximum leadwire resistance: 20 Ω per wire

OUTPUT SPECIFICATIONS

■ **Relay Contact:** SPDT relays

220 V AC @3 A (cos φ = 1)

30 V DC @3 A (resistive load)

Caution: N.O. and N.C. contacts could be conductive at the same time. DO NOT connect both contacts at the same time.

Maximum switching voltage: 220 V AC or 30 V DC

Maximum switching power: 660 VA or 90 W

Minimum load: 10 V DC @1 mA

Mechanical life: 2 × 10⁷ cycles with no loads

For maximum relay life with inductive loads, external protection is recommended.

INSTALLATION

Power consumption

• **AC:**

≤ 5 VA at 100 V

≤ 6 VA at 200 V

≤ 6 VA at 264 V

• **DC:** ≤ 2.5 W

Operating temperature: -10 to +55°C or 14 to 131°F
 (-10 to +50°C or 14 to 122°F for UL)

Operating humidity: 30 to 90 %RH (non-condensing)

Mounting: Panel flush mounting with attached mounting bracket, surface or DIN rail

Weight: 200 g (0.44 lb)

PERFORMANCE

Display accuracy

• **Thermocouple:** ±0.5 % FS ± 1 digit ± 3°C (5.4°F)

±1 % FS ± 1 digit ± 3°C (5.4°F) for T, E (≤ -100°C, ≤ -148 °F)

±5 % FS ± 1 digit ± 3°C (5.4°F) for B (0 - 500°C, 32 - 932°F)

±1 % FS ± 1 digit ± 3°C (5.4°F) for R (0 - 400°C, 32 - 752°F)

(In case of type B thermocouple the accuracy near 0°C may be degraded due to the characteristic of the sensor.)

•RTD: ±0.5 % FS ± 1 digit

Setpoint accuracy: Display accuracy ± 0.1 % FS

Trip point repeatability: Included in the setpoint accuracy

Cold junction compensation error: ±3°C at 25 ±5°C (±5.4°F at 77 ±9°F)

Burnout response: Approx. 10 sec.

Line voltage effect: Included in the display accuracy

Insulation resistance: ≥ 100 MΩ with 500 V DC

Dielectric strength: 1500 V AC @1 minute
(input to SET1 or SET2 to power)

500 V AC @1 minute (SET1 to SET2)

STANDARDS & APPROVALS

CE conformity:

EMC Directive (2004/108/EC)

EMI EN 61000-6-4: 2007/A1: 2011

EMS EN 61000-6-2: 2005

Low Voltage Directive (2006/95/EC)

EN 61010-1: 2010

Installation Category II (power)

Measurement Category II (output)

Pollution Degree 2

Input to output to power - Basic insulation (300 V)

Approval:

UL/C-UL Temperature-Indicating and -Regulating Equipment
(UL873:2013, CAN/CSA-C22.2 No.24-93:2008)

EXTERNAL VIEW

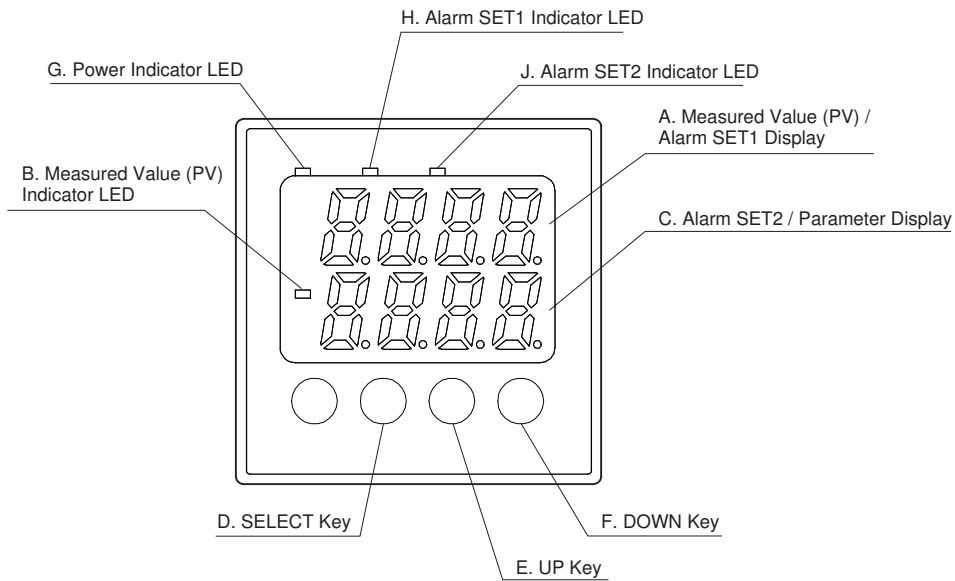

Ref.	Component Name	Function
A	Measured Value (PV) / Alarm SET1 Display	Displaying either of Measured Value (PV) or Alarm Setpoint Value (SET1)
B	Measured Value (PV) Indicator LED	Light turns on when the Measured Value (PV) is displayed.
C	Alarm SET2 / Parameter Display	Displaying either of Alarm Setpoint Value (SET2) or parameter type code.
D	SELECT Key	Used for confirming current setpoints and switching between parameter blocks.
E	UP Key	Pressing the key increases display values. They change continuously when it is kept pressed.
F	DOWN Key	Pressing the key decreases display values. They change continuously when it is kept pressed.
G	Power Indicator LED	Light turns on while the power is turned on.
H	Alarm SET1 Indicator LED	Light turns on when the Alarm SET1 is in tripped conditions.
J	Alarm SET2 Indicator LED	Light turns on when the Alarm SET2 is in tripped conditions.

EXTERNAL DIMENSIONS & TERMINAL ASSIGNMENTS unit: mm (inch)

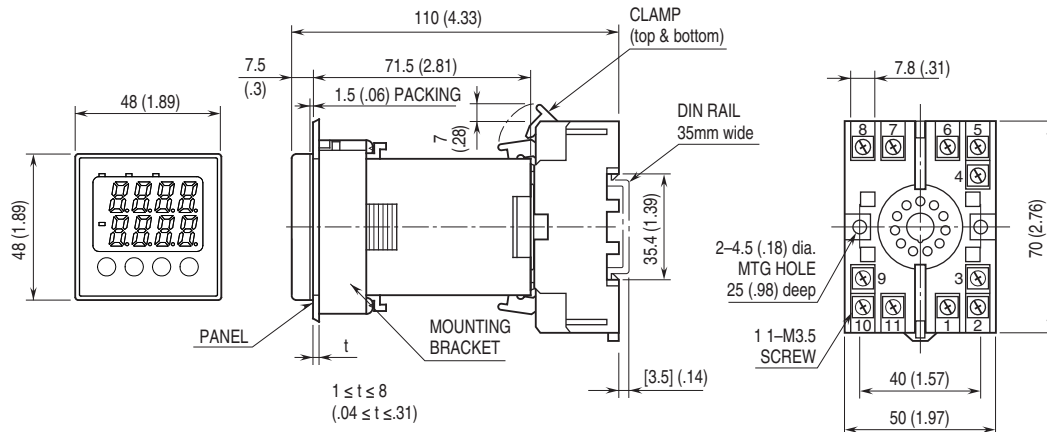

PANEL CUTOUT unit: mm

■ PANEL CUTOUT

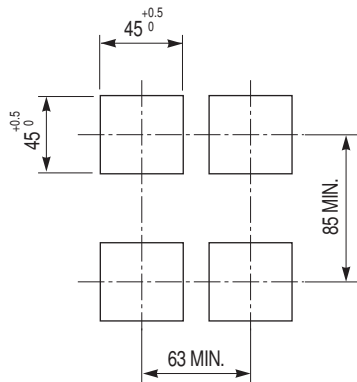

SCHEMATIC CIRCUITRY & CONNECTION DIAGRAM

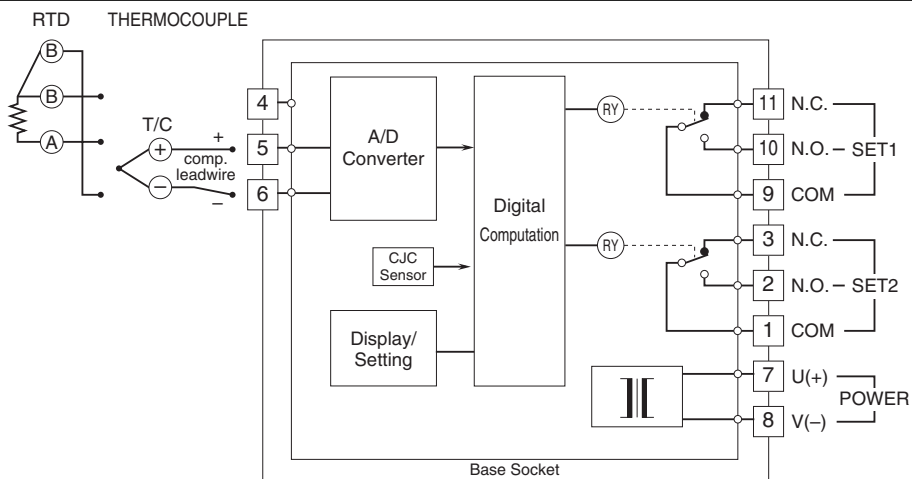

Specifications are subject to change without notice.