

32-1139 REV 1



Series R54 smart sensors measure bi-directional torque for a wide variety of applications across virtually all industries. Convert any wrench to a torque tool with this sensor, or use it as a component of a torque testing system. Capacities available from 20 to 5,000 lbFin [2 to 550 Nm]. Compatible with Mark-10 indicators (sold separately) through unique Plug & Test™ technology.

## Specifications

Accuracy:	±0.6% of full scale + indicator
Safe Overload:	150% of full scale
Weight:	0.6 - 2.0 lb [0.3 - 0.9 kg], depending on model

## Dimensions in [mm]

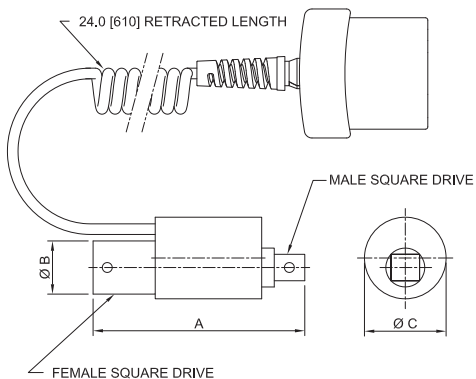

Model No.	A	ØB	ØC	Drive Size
MR54-20 - MR54-100	1.88 [47.8]	0.56 [14.2]	1.00 [25.4]	1/4"
MR54-200 - MR54-400	3.00 [76.2]	0.73 [18.5]	1.12 [28.6]	3/8"
MR54-1000	3.50 [88.9]	0.98 [24.9]	20.0 [508.0]	1/2"
MR54-5000	5.00 [127.0]	1.48 [37.6]	2.0 [50.8]	3/4"

## Capacity x Resolution

Model No.	With Models 7i & 5i indicators						With Model 3i indicator			
	lbFin	ozFin	lbFft	kgFmm	Ncm	Nm	lbFin	ozFin	kgFmm	Ncm
MR54-20	20 x 0.02	320 x 0.2	1.5 x 0.002	-	220 x 0.2	2 x 0.002	20 x 0.02	320 x 0.5	-	220 x 0.2
MR54-50	50 x 0.05	800 x 0.5	4 x 0.005	-	570 x 0.5	5.7 x 0.005	50 x 0.05	800 x 1	-	570 x 0.5
MR54-100	100 x 0.1	1600 x 1	8 x 0.01	-	1150 x 1	11.5 x 0.01	100 x 0.1	1600 x 2	-	1150 x 1
MR54-200	200 x 0.2	-	16 x 0.02	2300 x 2	2200 x 2	22 x 0.02	200 x 0.2	-	2300 x 2	2200 x 2
MR54-400	400 x 0.5	-	32 x 0.05	4600 x 5	4500 x 5	45 x 0.05	400 x 0.5	-	4600 x 5	4500 x 5
MR54-1000	1000 x 1	-	80 x 0.1	11500 x 10	11000 x 10	110 x 0.1	1000 x 1	-	11500 x 10	11000 x 10
MR54-5000	5000 x 5	-	400 x 0.5	55 x 0.05 kgFm	55000 x 50	550 x 0.5	5000 x 5	-	55 x 0.05 kgFm	550 x 0.5 Nm



< Unique Plug & Test™ technology allows for interchangeable sensors to be used with a Mark-10 indicator. All calibration and configuration data is saved in the smart connector.



< The Plug & Test™ connector locks into the receptacle in the indicator when fully inserted. Dual buttons on the indicator housing release the connector for easy removal. Gold plated spring contacts ensure long lasting and reliable connection.



^ Optional AC1010 mounting kit is used to hold an MR54-200 or MR54-400 sensor in place.



^ Optional AC1016 mounting kit mounts an MR54-200 or MR54-400 sensor to a torque test stand.

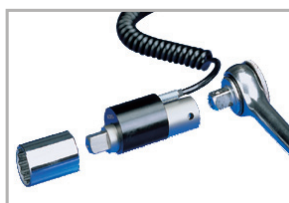

< A Series R54 sensor is shown set up for a typical torque wrench testing application.

## Optional Items

AC1010	Mounting kit, tabletop, MR54-200 - MR54-400
AC1016	Mounting kit, MR54-200 - MR54-400 to torque test stand



Mark-10 Corporation ■ www.mark-10.com ■ info@mark-10.com  
Toll-free: 888-MARK-TEN ■ Tel: 631-842-9200 ■ Fax: 631-842-9201



Specifications subject to change without prior notice