



Defender[®] 5000

Standard Bench Scale Bases



Counting function is not legal for trade

Durable Bases for the Most Demanding of Industrial Applications

The OHAUS next generation Defender 5000 R and W Series bases offer two levels of durability for the most demanding of industrial applications. Both bases offer moisture-protected single-point load cells, steel construction, non-slip rubber adjustable feet, removable stainless steel weighing pans, and integrated leveling bubbles. Maximum non-approved resolution of 25,000d meets the needs of industrial weighing applications that require extreme accuracy.

Standard Features:

- **Durably Constructed To Withstand Harsh Industrial Environments**

The R Series features a stainless steel platform, powder-painted steel frame and an aluminum load cell. The W series features a stainless steel platform, frame, and an IP67 washdown stainless steel loadcell.

- **Install Easily with the EasyConnect™ Feature**

The Defender 5000 bases are equipped with an EasyConnect cable, which allows instant configuration with Defender 5000 (TD52) indicators, speeding up installation.

- **Backed by Approvals for Legal-for-Trade Applications**

Defender 5000 bases are NTEP and Measurement Canada certified up to 6,250e which make them ideal for legal-for-trade use.

Ingenuously Practical

Defender[®] 5000 Standard Bench Scale Bases

Specifications

Model	D12RQR	D25RQR	D50RQR	D12RTR	D25RTR	D50RTR	D50RQL	D125RQL	
Capacity x Default Readability	25 lb × 0.001 lb 12.5 kg × 0.5 g	50 lb × 0.002 lb 25 kg × 1 g	100 lb × 0.005 lb 50 kg × 2 g	25 lb × 0.001 lb 12.5 kg × 0.5 g	50 lb × 0.002 lb 25 kg × 1 g	100 lb × 0.005 lb 50 kg × 2 g		250 lb × 0.01 lb 125 kg × 5 g	
Capacity x Certified Readability	25 lb × 0.005 lb 12.5 kg × 2 g	50 lb × 0.01 lb 25 kg × 5 g	100 lb × 0.02 lb 50 kg × 10 g	25 lb × 0.005 lb 12.5 kg × 2 g	50 lb × 0.01 lb 25 kg × 5 g	100 lb × 0.02 lb 50 kg × 10 g		250 lb × 0.05 lb 125 kg × 20 g	
Safe Overload Capacity	150% of capacity								
Base Construction	Stainless steel removable weighing platform, powder-coated steel base construction								
Linearity/Repeatability	± 2d								
Load Cell Capacity	48 lb / 22 kg	110 lb / 50 kg	220 lb / 100 kg	48 lb / 22 kg	110 lb / 50 kg	220 lb / 100 kg		440 lb / 200 kg	
Load Cell Cable	4.9 ft / 1.5 m L × 6-wire	6.5 ft / 2 m L × 6-wire		4.9 ft / 1.5 m L × 6-wire	6.5 ft / 2 m L × 6-wire				
Load Cell Type	350 Ohm, aluminum, single point								
Load Cell Excitation	5-15V DC/AC								
Load Cell Rated Output	2mV/V								
Load Cell Protection	IP67								
Base Dimensions (B × A × C × D × E)	12 × 12 × 3.9 × 2.4 × 13.3 in 305 × 305 × 99 × 60 × 338 mm			12 × 14 × 3.9 × 2.4 × 15.3 in 305 × 355 × 355 × 99 × 60 × 388 mm			18 × 18 × 4.3 × 2.8 × 19.1 in 457 × 457 × 110 × 70 × 485 mm		
Shipping Dimensions (L × W × H)	18.9 × 17.5 × 14.3 in 480 × 445 × 363 mm					39.1 × 26.8 × 9.25 in 994 × 680 × 235 mm			
Net Weight	14.3 lb / 6.5 kg			15.5 lb / 7 kg			18.7 lb / 8.5 kg		
Shipping Weight	17.6 lb / 8 kg			18.7 lb / 8.5 kg			18.7 lb / 8.5 kg		

Model	D50RTX	D125RTX	D250RTX	D50RQV	D125RQV	D250RQV	D500RQV	D125RTV	D250RTV	D500RTV
Capacity x Default Readability	100 lb × 0.005 lb 50 kg × 2 g	250 lb × 0.01 lb 125 kg × 5 g	500 lb × 0.02 lb 250 kg × 10 g	100 lb × 0.005 lb 50 kg × 2 g	250 lb × 0.01 lb 125 kg × 5 g	500 lb × 0.02 lb 250 kg × 10 g	1000 lb × 0.05 lb 500 kg × 20 g	250 lb × 0.01 lb 125 kg × 5 g	500 lb × 0.02 lb 250 kg × 10 g	1000 lb × 0.05 lb 500 kg × 20 g
Capacity x Certified /Certified Readability	100 lb × 0.02 lb 50 kg × 10 g	250 lb × 0.05 lb 125 kg × 20 g	500 lb × 0.1 lb 250 kg × 50 g	100 lb × 0.02 lb 50 kg × 10 g	250 lb × 0.05 lb 125 kg × 20 g	500 lb × 0.1 lb 250 kg × 50 g	1000 lb × 0.2 lb 500 kg × 100 g	250 lb × 0.05 lb 125 kg × 20 g	500 lb × 0.1 lb 250 kg × 50 g	1000 lb × 0.2 lb 500 kg × 100 g
Safe Overload Capacity	150% of capacity									
Base Construction	Stainless steel removable weighing platform, powder-coated steel base construction									
Linearity /Repeatability	± 2d									
Load Cell Capacity	220 lb / 100 kg	550 lb / 250 kg	1,100 lb / 500 kg	220 lb / 100 kg	550 lb / 250 kg	1,100 lb / 500 kg	1,650 lb / 750 kg	550 lb / 250 kg	1,100 lb / 500 kg	1,650 lb / 750 kg
Load Cell Cable	6.5 ft / 2 m L × 6-wire									
Load Cell Type	350 Ohm, aluminum, single point									
Load Cell Excitation	5-15V DC/AC									
Load Cell Rated Output	2mV/V									
Load Cell Protection	IP67									
Base Dimensions (B × A × C × D × E)	24 × 18 × 5.1 × 3.6 × 24.5 in 610 × 457 × 130 × 90 × 633 mm			24 × 24 × 5.1 × 3.6 × 24.5 in 610 × 610 × 130 × 90 × 633 mm			31.5 × 23.6 × 5.2 × 3.6 × 32.3 in 800 × 600 × 132 × 90 × 821 mm			
Shipping Dimensions (L × W × H)	39.1 × 26.8 × 9.25 in 994 × 680 × 235 mm				45.9 × 30.7 × 9.25 in 1165 × 780 × 235 mm					
Net Weight	48.5 lb / 22 kg				68.3 lb / 31 kg				90 lb / 39 kg	
Shipping Weight	52.9 lb / 24 kg				75 lb / 34 kg				92.6 lb / 42 kg	

Defender[®] 5000 Washdown Standard Bench Scale Bases

Specifications

Model	D2WQS	D5WQS	D12WQS	D12WQR	D25WQR	D50WQR	D25WQL	D50WQL	D125WQL
Capacity x Default Readability	5 lb × 0.0002 lb 2.5 kg × 0.1 g	10 lb × 0.001 lb 5 kg × 0.5 g	10 lb × 0.0005 lb 5 kg × 0.2 g		50 lb × 0.002 lb 25 kg × 1 g	100 lb × 0.005 lb 50 kg × 2 g	50 lb × 0.002 lb 25 kg × 1 g	100 lb × 0.005 lb 50 kg × 2 g	250 lb × 0.01 lb 125 kg × 5 g
Capacity x Certified Readability	5 lb × 0.001 lb 2.5 kg × 0.5 g	10 lb × 0.002 lb 5 kg × 1 g	25 lb × 0.005 lb 12.5 kg × 5 g		50 lb × 0.01 lb 25 kg × 5 g	100 lb × 0.02 lb 50 kg × 10 g	50 lb × 0.01 lb 25 kg × 5 g	100 lb × 0.02 lb 50 kg × 10 g	250 lb × 0.05 lb 125 kg × 50 g
Safe Overload Capacity	150% of capacity								
Base Construction	Stainless steel removable weighing platform with stainless steel frame								
Linearity /Repeatability	± 2d								
Load Cell Capacity	13 lb / 6 kg	22 lb / 10 kg	66 lb / 30 kg		110 lb / 50 kg	220 lb / 100 kg	110 lb / 50 kg	220 lb / 100 kg	440 lb / 200 kg
Load Cell Cable	3.2 ft / 1 m L x 4-wire				6.5 ft / 2 m L x 6-wire				
Load Cell Type	350 Ohm, stainless steel, single point								
Load Cell Excitation	5-15V DC/AC								
Load Cell Rated Output	2mV/V								
Load Cell Protection	IP67								
Base Dimensions (B x A x C x D x E)	10 × 10 × 2.9 × 1.8 × 11.1 in 254 × 254 × 74 × 45 × 282 mm			12 × 12 × 3.9 × 2.4 × 12.9 in 305 × 305 × 99 × 60 × 328 mm			18 × 18 × 4.3 × 2.8 × 18.9 in 457 × 457 × 110 × 70 × 480 mm		
Shipping Dimensions (L x W x H)	18.9 × 17.5 × 14.3 in 480 × 445 × 363 mm						39.1 × 26.8 × 9.25 in 994 × 680 × 235 mm		
Net Weight	10 lb / 4.5 kg			13.2 lb / 6 kg			28.7 lb / 13 kg		
Shipping Weight	13.2 lb / 6 kg			18.7 lb / 8.5 kg			33.1 lb / 15 kg		

Model	D50WTX	D125WTX	D250WTX	D50WQV	D125WQV	D250WQV	D500WQV
Capacity x Default Readability	100 lb × 0.005 lb 50 kg × 2 g	250 lb × 0.01 lb 125 kg × 5 g	500 lb × 0.02 lb 250 kg × 10 g	100 lb × 0.005 lb 50 kg × 2 g	250 lb × 0.01 lb 125 kg × 5 g	500 lb × 0.02 lb 250 kg × 10 g	1000 lb × 0.05 lb 500 kg × 20 g
Capacity x Certified Readability	100 lb × 0.02 lb 50 kg × 10 g	250 lb × 0.05 lb 125 kg × 50 g	500 lb × 0.1 lb 250 kg × 50 g	100 lb × 0.02 lb 50 kg × 20 g	250 lb × 0.05 lb 125 kg × 50 g	500 lb × 0.1 lb 250 kg × 50 g	1000 lb × 0.2 lb 500 kg × 100 g
Safe Overload Capacity	150% of capacity						
Base Construction	Stainless steel removable weighing platform with stainless steel frame						
Linearity /Repeatability	± 2d						
Load Cell Capacity	330 lb / 150 kg	660 lb / 300 kg	1,100 lb / 500 kg	330 lb / 150 kg	660 lb / 300 kg	1,100 lb / 500 kg	1,650 lb / 750 kg
Load Cell Cable	6.5 ft / 2 m L x 6-wire						
Load Cell Type	350 Ohm, stainless steel, single point						350 Ohm, aluminum, single point
Load Cell Excitation	5-15V DC/AC						
Load Cell Rated Output	2mV/V						
Load Cell Protection	IP67						
Base Dimensions (B x A x C x D x E)	24 × 18 × 5.1 × 3.6 × 24.5 in 610 × 457 × 130 × 90 × 633 mm			24 × 24 × 5.1 × 3.6 × 24.5 in 610 × 610 × 130 × 90 × 633 mm			
Shipping Dimensions (L x W x H)	39.1 × 26.8 × 9.25 in 994 × 680 × 235 mm			45.9 × 30.7 × 9.25 in 1165 × 780 × 235 mm			
Net Weight	52.9 lb / 24 kg			68.3 lb / 31 kg			
Shipping Weight	59.5 lb / 27 kg			75 lb / 34 kg			

Defender[®] 5000 Standard Bench Scale Bases

Dimensions

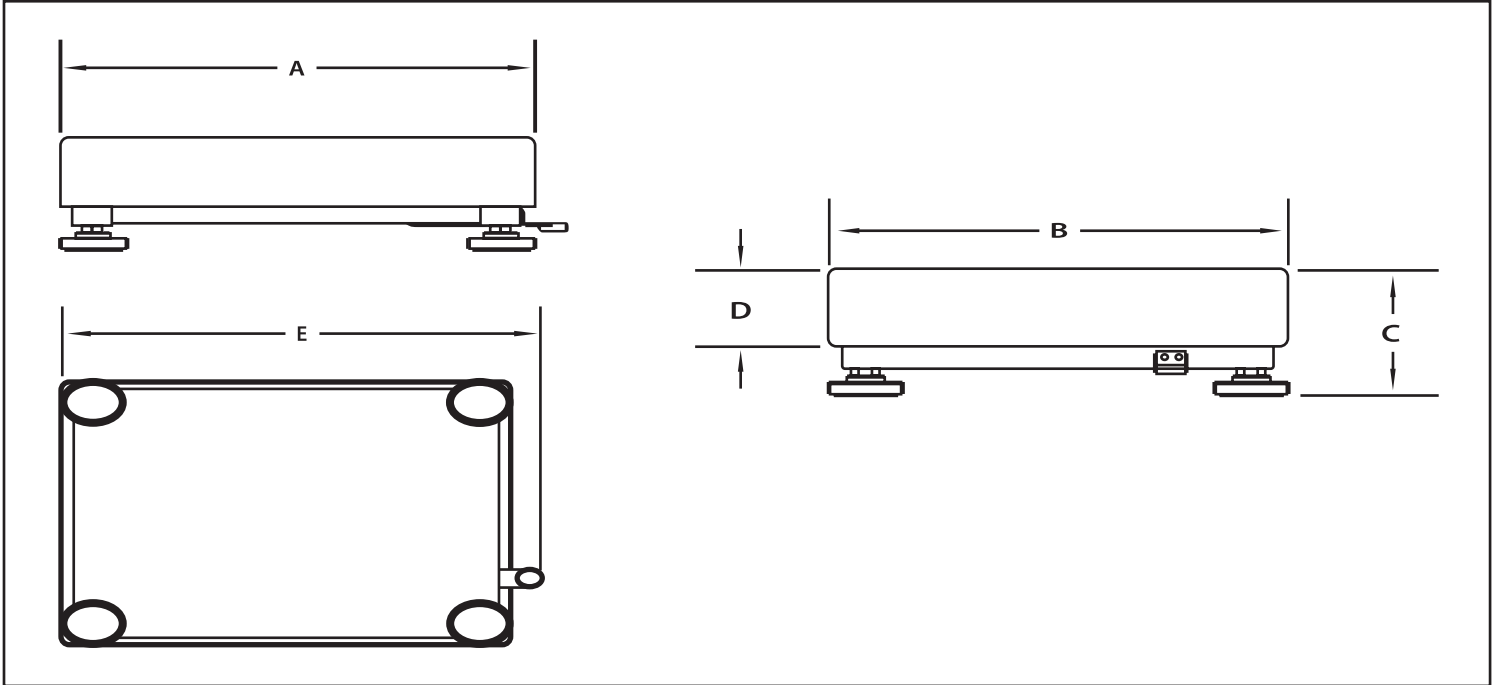

Compliance

- Metrology: Measurement Canada (NoA AM-6107); NTEP (CC 18-077), Class III
- Compliance Marks: CE

Construction

R Series Base: 304-grade stainless steel platform, sand grey powder coated steel frame, aluminum load cell, level indicator

W Series Base: 304-grade stainless steel platform, stainless steel frame, stainless steel IP67 load cell, stainless steel level indicator

Accessories

Column Kit, 35 cm, CS, D52	30424410
Column Kit, 68 cm, CS, D52	30424411
Column Kit, 98 cm, CS, D52	30424412
Column Kit, 35 cm, SST, D52	30424413
Column Kit, 68 cm, SST, D52	30424414
Column Kit, 98 cm, SST, D52	30424415
Front Mount Kit, D52	30424024
Print Holder Kit, D52	30424025
LC Extension Cable, 9 meters, D52 ¹	30424409
Load Cell Cable Adapter Kit, to D52 Base	30429931
Wheel Kit, Defender Series (for bases up to 300 kg) ¹ ..	30372146

¹ Cannot be used for legal-for-trade applications

OHAUS CORPORATION
7 Campus Drive
Suite 310
Parsippany, NJ 07054 USA

Tel: 800.672.7722
973.377.9000
Fax: 973.944.7177

www.ohaus.com

The management system
governing the manufacture
of this product is
ISO 9001:2015 certified.

